

# A15

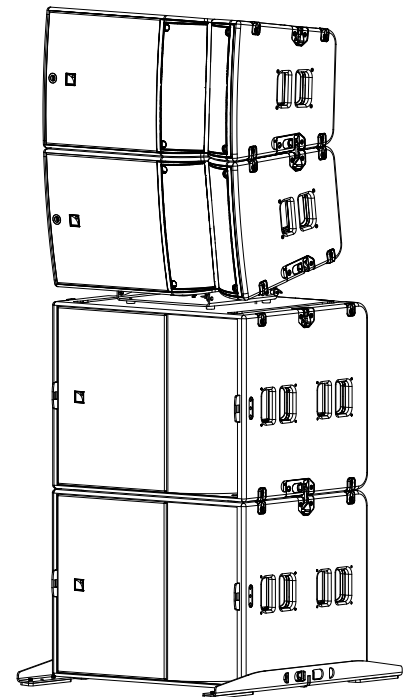

## owner's manual (EN)

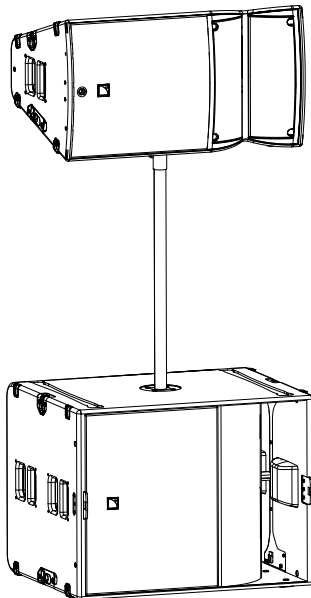
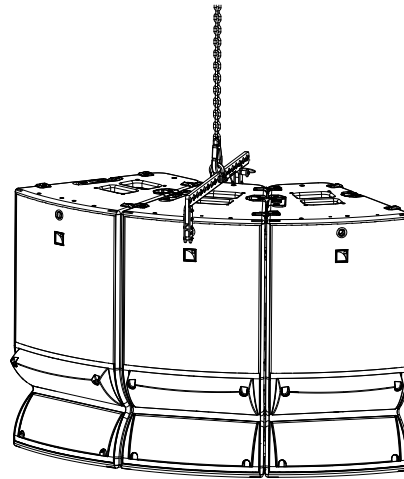
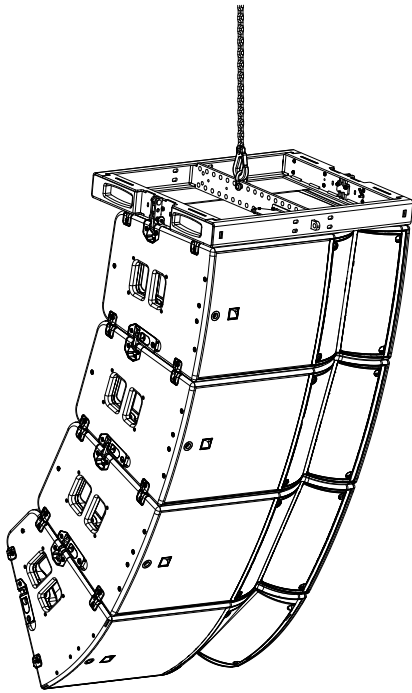

Document reference: A15 owner's manual (EN) version 3.1

Distribution date: July 27, 2022

© 2022 L-Acoustics. All rights reserved.

No part of this publication may be reproduced or transmitted in any form or by any means without the express written consent of the publisher.



## Contents

|  |    |
|--|----|
| Safety.....                                  | 6  |
| Instructions.....                            | 6  |
| Introduction.....                            | 8  |
| A15 family.....                              | 8  |
| How to use this manual.....                  | 9  |
| Revision history.....                        | 10 |
| System components.....                       | 11 |
| Electro-acoustical description.....          | 14 |
| Adjustable fins.....                         | 14 |
| Directivity.....                             | 16 |
| Symmetrical configurations.....              | 19 |
| Preset description.....                      | 20 |
| Connectors.....                              | 21 |
| Rigging system description.....              | 22 |
| A15 system rigging.....                      | 22 |
| Enclosures.....                              | 24 |
| A15 Wide/Focus.....                          | 24 |
| KS21.....                                    | 25 |
| Rigging elements for flown arrays.....       | 26 |
| A15-BUMP.....                                | 26 |
| M-BAR.....                                   | 28 |
| A15-RIGBAR.....                              | 29 |
| A15-LIFT.....                                | 31 |
| Rigging elements for stacked arrays.....     | 34 |
| A-TILT.....                                  | 34 |
| KS21-OUTRIG.....                             | 36 |
| K2-JACK.....                                 | 37 |
| Rigging elements for a single enclosure..... | 39 |
| A-MOUNT.....                                 | 39 |
| X-BAR.....                                   | 40 |
| Storage and handling elements.....           | 42 |
| KS21-CHARIOT.....                            | 42 |
| KS21-PLA.....                                | 43 |
| KS21-COV and KS21-CHARIOTCOV.....            | 44 |
| Flight case for A15 Wide/Focus.....          | 44 |







|   |     |
|---|-----|
| Mechanical safety.....                                | 46  |
| Loudspeaker configurations.....                       | 49  |
| A15 Wide/Focus line source.....                       | 49  |
| With low-frequency element.....                       | 50  |
| A15 Wide/Focus line source element.....               | 51  |
| With low-frequency element.....                       | 52  |
| A15 Wide/Focus stage monitor.....                     | 53  |
| Low-latency preset.....                               | 53  |
| With low-frequency element.....                       | 54  |
| Inspection and preventive maintenance.....            | 55  |
| How to do preventive maintenance.....                 | 55  |
| Rigging part inspection.....                          | 55  |
| Mechanical system overview.....                       | 56  |
| Inspection references.....                            | 63  |
| Rigging check.....                                    | 69  |
| Acoustical check.....                                 | 71  |
| Rigging procedures.....                               | 75  |
| Flying.....   | 75  |
| Flying a vertical array with A15-BUMP/A15-RIGBAR..... | 75  |
| Adding a pullback with A15-BUMP/A15-RIGBAR.....       | 84  |
| Flying a radial array with A15-LIFT.....              | 86  |
| Flying a single enclosure with X-BAR.....             | 92  |
| Stacking.....   | 95  |
| Stacking A15 Wide/Focus on KS21 with A-TILT.....      | 95  |
| Stacking KS21 on KS21-CHARIOT.....                    | 99  |
| Attaching K2-JACK stabilizers to KS21-CHARIOT.....    | 101 |
| Pole-mounting.....                                    | 104 |
| Connection to LA amplified controllers.....           | 106 |
| Corrective maintenance.....                           | 107 |
| Tools and consumables.....                            | 107 |
| A15 Focus.....  | 108 |
| A15 Wide.....   | 116 |
| KS21.....   | 124 |

|  |     |
|--|-----|
| Specifications.....  | 133 |
| APPENDIX A: Authorized configurations with A15-LIFT.....         | 150 |
| APPENDIX B: Installing the LAP-TEQ inclinometer on A15-BUMP..... | 152 |
| APPENDIX C: Recommendation for speaker cables.....               | 153 |

# Safety

## Instructions

---

-  **Inspect the system before any deployment.**  
Perform safety related checks and inspections before any deployment.
- Perform preventive maintenance at least once a year.**  
Refer to the preventive maintenance section for a list of actions and their periodicity.  
Insufficient upkeep of the product can void the warranty.
- If any safety issue is detected during inspection, do not use the product before performing corrective maintenance.**  
Check for issues. A rigging system part or fastener is missing or loose. A rigging system part exhibits: bends, breaks, broken parts, corrosion, cracks, cracks in welded joints, deformation, denting, wear, holes. A safety cue or label is missing.
-  **Never incorporate equipment or accessories not approved by L-Acoustics.**
-  **Read all the related PRODUCT INFORMATION documents shipped with the products before exploiting the system.**
-  **Do not store the product on an unstable cart, stand, tripod, bracket, or table.**
-  **Beware of sound levels.**  
Do not stay within close proximity of loudspeakers in operation.  
Loudspeaker systems are capable of producing very high sound pressure levels (SPL) which can instantaneously lead to permanent hearing damage to performers, production crew and audience members. Hearing damage can also occur at moderate level with prolonged exposure to sound.  
Check the applicable laws and regulations relating to maximum sound levels and exposure times.
-  **Work with qualified personnel for rigging the system**  
Installation should only be carried out by qualified personnel that are familiar with the rigging techniques and safety recommendations outlined in this manual.
- Ensure personnel health and safety**  
During installation and set-up personnel must wear protective headgear and footwear at all times. Under no circumstances is personnel allowed to climb on a loudspeaker assembly.
- Respect the Working Load Limit (WLL) of third party equipment.**  
L-Acoustics is not responsible for any rigging equipment and accessories provided by third party manufacturers. Verify that the Working Load Limit (WLL) of the suspension points, chain hoists and all additional hardware rigging accessories is respected.
- Respect the maximum configurations and the recommended safety precautions.**  
For safety issue, respect the maximum configurations outlined in this manual. To check the conformity of any configuration in regards with the safety precautions recommended by L-Acoustics, model the system in Soundvision and refer to the warnings in Mechanical Data section.
- Be cautious when flying a loudspeaker configuration.**  
Before installing/raising the product, check each individual element to make sure that it is securely fastened to the adjacent element. Always verify that no one is standing underneath the product when it is being installed/raised. Never leave the product unattended during the installation process.  
As a general rule, L-Acoustics recommends the use of secondary safety at all times.
- Be cautious when ground-stacking a loudspeaker array.**  
Do not stack the loudspeaker array on unstable ground or surface. If the array is stacked on a structure, platform, or stage, always check that the latter can support the total weight of the array.  
As a general rule, L-Acoustics recommends the use of safety straps at all times.

**Risk of falling objects**

Verify that no unattached items remain on the product or assembly.

**Risk of tipping**

Remove all rigging accessories before transporting a product or an assembly.

**Take into account the wind effects on dynamic load.**

When a loudspeaker assembly is deployed in an open air environment, wind can produce dynamic stress to the rigging components and suspension points.

If the wind force exceeds 6 bft (Beaufort scale), lower down and/or secure the product or the assembly.

**Intended use**

This system is intended for use by trained personnel for professional applications.



**As part of a continuous evolution of techniques and standards, L-Acoustics reserves the right to change the specifications of its products and the content of its documents without prior notice.**

Check [www.l-acoustics.com](http://www.l-acoustics.com) on a regular basis to download the latest document and software updates.

**Long term exposure to extreme conditions may damage the product.**

For more information, refer to the **Products weather protection** document, available on the website.

**Read the maintenance section of this document before servicing the product.****Contact L-Acoustics for advanced maintenance.**

Any unauthorized maintenance operation will void the product warranty.



This marking indicates that this product should not be disposed of with other household waste throughout the EU. To prevent possible harm to the environment or human health from uncontrolled waste disposal, recycle it responsibly to promote the sustainable reuse of material resources. To return your used device, please use the return and collection systems or contact the retailer where the product was purchased. They can take this product for environmentally safe recycling.



# Introduction

## A15 family

---

A15 is a constant curvature WST® product line designed for medium throw production applications up to 45 m. The highly multifunctional family includes A15 Focus and A15 Wide, passive 15" systems with distinct coverage patterns. A15 products can be flown or stacked in combinations to form vertical or horizontal line sources or used individually as configurable directivity point sources.

The A15 can adapt to virtually any audience geometry with two enclosure coverage options (10° or 30°), L-Fins for user configurable waveguide directivity (70°, 110° or 90° asymmetrical) and a range of accessories for vertical or horizontal deployment.

A15 deployment requires a single preset that is optimized to provide amazing plug-and-play performance for both A15 models regardless of L-Fins configuration. Performance can be further enhanced with L-Acoustics software optimization tools.

A15 provides the low frequency contour of a large concert system and the dedicated KS21 subwoofer can be ground-stacked or flown with A15 products to reinforce contour and extend bandwidth to 29 Hz.

The A15 family is a highly scalable system that can do it all – delivering concert level performance for events large and small or supplementing a larger L-Acoustics solution for the world's biggest stages.

## How to use this manual

---

The A15 owner's manual is intended for all actors involved in the system design, implementation, preventive and corrective maintenance of the A15 system. It must be used as follows:

1. Read the technical description for an overview of all system elements, their features, and their compatibilities.
  - [Electro-acoustical description](#) (p.14)
  - [Rigging system description](#) (p.22)
2. Prepare the system configuration. Consider the mechanical limits and the available acoustical configurations.
  - [Mechanical safety](#) (p.46)
  - [Loudspeaker configurations](#) (p.49)
3. Before rigging the system, perform mandatory inspections and functional checks.
  - [Inspection and preventive maintenance](#) (p.55)
4. To deploy the system, follow the step-by-step rigging instructions and refer to the cabling schemes.
  - [Rigging procedures](#) (p.75)
  - [Connection to LA amplified controllers](#) (p.106)



The [Corrective maintenance](#) (p.107) section contains the operations authorized for the end user. Performing another operation exposes to hazardous situations. For advanced maintenance, contact your L-Acoustics representative.

**As part of a continuous evolution of techniques and standards, L-Acoustics reserves the right to change the specifications of its products and the content of its document without prior notice.** Please check [www.l-acoustics.com](http://www.l-acoustics.com) on a regular basis to download the latest document and software updates.

### Contact information

For information on advanced corrective maintenance:

- contact your Certified Provider or your L-Acoustics representative
- for Certified Providers, contact the L-Acoustics customer service: [customer.service@l-acoustics.com](mailto:customer.service@l-acoustics.com) (EMEA/APAC), [laus.service@l-acoustics.com](mailto:laus.service@l-acoustics.com) (Americas).

### Symbols

The following symbols are used in this document:



This symbol indicates a potential risk of harm to an individual or damage to the product.

It can also notify the user about instructions that must be strictly followed to ensure safe installation or operation of the product.



This symbol notifies the user about instructions that must be strictly followed to ensure proper installation or operation of the product.



This symbol notifies the user about complementary information or optional instructions.

## Revision history

| version number | publication date | modification   |
|----------------|------------------|--|
| 1.0            | May 2019         | Initial version.   |
| 1.1            | Jun. 2019        | Minor fixes and improvements.  |
| 1.2            | Jun. 2019        |  |
| 2.0            | Aug. 2019        | <ul style="list-style-type: none"> <li>• Added Inspection and preventive maintenance section.</li> <li>• Added Corrective maintenance section.</li> <li>• Added Flight Case description.</li> </ul>  |
| 2.1            | Oct 2019         | <ul style="list-style-type: none"> <li>• Added xxx_xxxx_Cx presets.</li> <li>• Added regulatory instructions for chariot and dolly use.</li> </ul>   |
| 2.2            | Jan. 2020        | Updated Corrective maintenance section following product updates.  |
| 3.0            | Oct. 2021        | <ul style="list-style-type: none"> <li>• Changed maximum limits for pullback configurations following the release of Soundvision 3.6.0. See <a href="#">Mechanical safety</a> (p.46).</li> <li>• Updated Corrective maintenance section following product updates.</li> </ul>  |
| 3.1            | Jul. 2022        | <ul style="list-style-type: none"> <li>• Changed maximum limit for KS21 stacked with no rigging accessory. Added maximum limit for KS21 on KS21-CHARIOT with K2-JACK. See <a href="#">Mechanical safety</a> (p.46).</li> <li>• Added [A15_MO] preset for stage monitor configurations. See <a href="#">A15 Wide/Focus stage monitor</a> (p.53).</li> </ul> |



## System components

### Loudspeaker enclosures

|           |   |
|-----------|---|
| A15 Focus | 2-way passive constant curvature WST® 10° enclosure: 15" LF + 3" HF diaphragm |
| A15 Wide  | 2-way passive constant curvature WST® 30° enclosure: 15" LF+ 3" HF diaphragm  |
| KS21      | High power compact subwoofer: 1x21"   |

### Powering and driving system

LA4X / LA8 / LA12X Amplified controller with DSP, preset library and networking capabilities



Refer to the LA4X / LA8 / LA12X owner's manual for operating instructions.

### Rack

LA-RAK II AVB Touring rack containing three LA12X, LA-POWER II for power distribution, LA-PANEL II for audio and network distribution, and two LS10 for AVB distribution

### Cables

|           |  |
|-----------|--|
| SP cables | SpeakON loudspeaker cables (4-point, 4 mm <sup>2</sup> gauge)<br>Come in different sizes: SP.7 (0.7 m / 2.3 ft), SP5 (5 m / 16.4 ft), SP10 (10 m / 32.8 ft), and SP25 (25 m / 82 ft) |
| SP-Y1     | Breakout cable for two passive enclosures (2.5 mm <sup>2</sup> gauge)<br>4-point speakON to 2 × 2-point speakON, provided with a CC4FP adapter                                       |
| DO cables | PA-COM loudspeaker cables (8-point, 4 mm <sup>2</sup> gauge)<br>Come in different sizes: DO.7 (0.7 m / 2.3 ft), DO.10 (10 m / 32.8 ft), and DO.25 (25 m / 82 ft)                     |
| DOSUB-LA8 | Breakout cable for four passive enclosures (4 mm <sup>2</sup> gauge)<br>8-point PA-COM to 4 × 2-point speakON  |



**Information about the connection of the enclosures to the LA amplified controllers is given in this document.**

Refer to the LA4X / LA8 / LA12X owner's manual for detailed instructions about the whole cabling scheme, including modulation cables and network.

### Rigging elements

|             |  |
|-------------|--|
| A15-BUMP    | Flying frame for vertical deployment of A15 and KS21 |
| A15-LIFT    | Rigging element for horizontal deployment of A15     |
| A15-RIGBAR  | Rigging bar and pullback for A15 and KS21            |
| A-TILT      | Rigging element for stacking A15 and A10 onto KS21   |
| KS21-OUTRIG | Stability bars for KS21                              |
| A-MOUNT     | Pole mount for A15 and A10                           |
| M-BAR       | Extension bar for rigging frame                      |
| X-BAR       | Rigging bar for 1 enclosure                          |
| K2-JACK     | 4 tilt adjustment screw jacks + bar for K2-CHARIOT   |
| CLAMP250    | Clamp certified for 250 kg                           |
| LA-SLING2T  | Lifting chain (DIN EN 818-4) 2-leg , 8 mm            |

### Transportation accessories

|                 |  |
|-----------------|--|
| L-Case          | 2U Electronics transport and protection case     |
| KS21-CHARIOT    | Chariot for up to 3 KS21                         |
| KS21-PLA        | Removable front dolly for 1 KS21                 |
| KS21-COV        | Protective cover for 1 KS21                      |
| KS21-CHARIOTCOV | Protective cover for 2 or 3 KS21 on KS21-CHARIOT |

### Software applications

|                    |   |
|--------------------|---|
| Soundvision        | 3D acoustical and mechanical modeling software                      |
| LA Network Manager | Software for remote control and monitoring of amplified controllers |

**i** Refer to the **Soundvision** help.  
**i** Refer to the **LA Network Manager** help.

## System component illustrations

---

### Cables

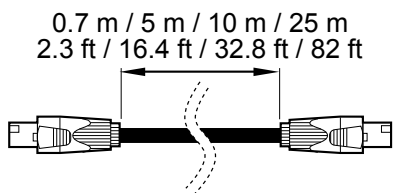

SP cables

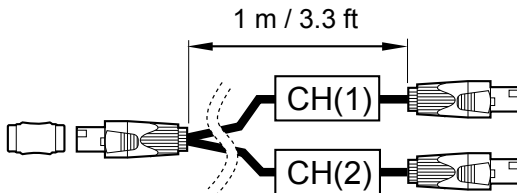

SP-Y1

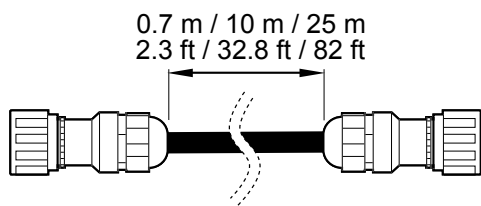

DO cables

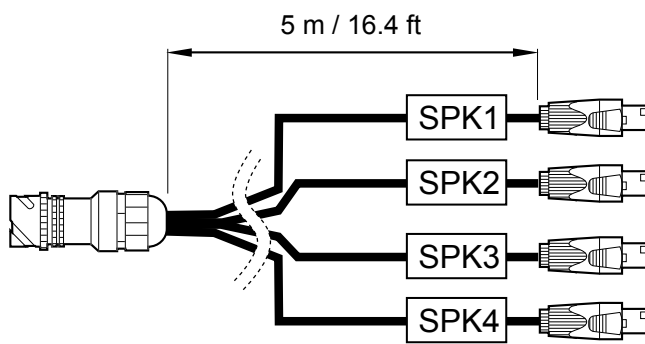

DOSUB-LA8

### Rigging accessories

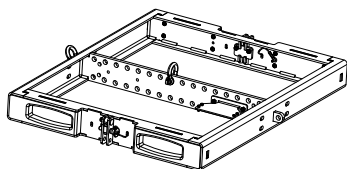

A15-BUMP

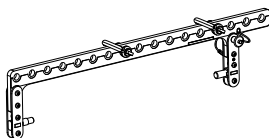

A15-LIFT

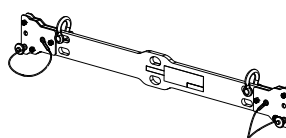

A15-RIGBAR

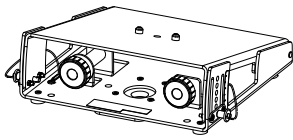

A-TILT

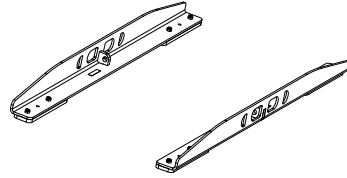

KS21-OUTRIG

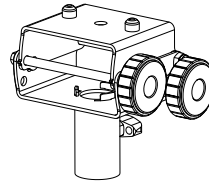

A-MOUNT

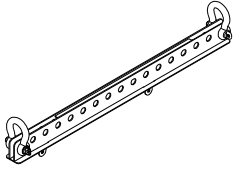

M-BAR

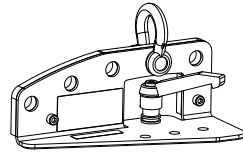

X-BAR

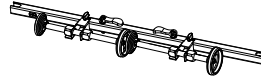

K2-JACK

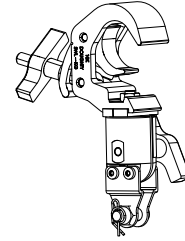

CLAMP250

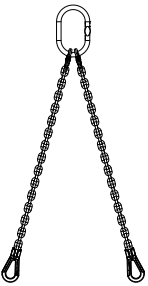

LA-SLING2T

## Transportation

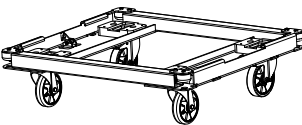

KS21-CHARIOT

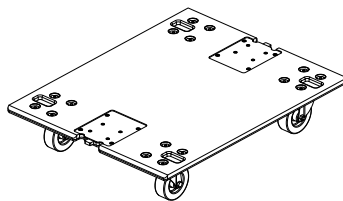

KS21-PLA

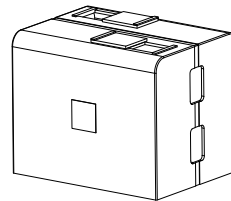

KS21-COV

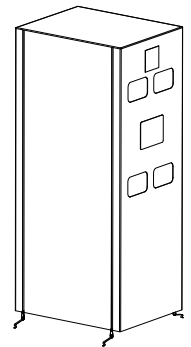

KS21-CHARIOTCOV

## Electro-acoustical description

### Adjustable fins

---

A15 Focus and A15 Wide feature L-Fins to adjust the waveguide directivity to one of four settings: 110° / 70° symmetric or 90° asymmetric (35°/55° or 55°/35°).

The same [A15] preset drives all directivity settings of both enclosures.

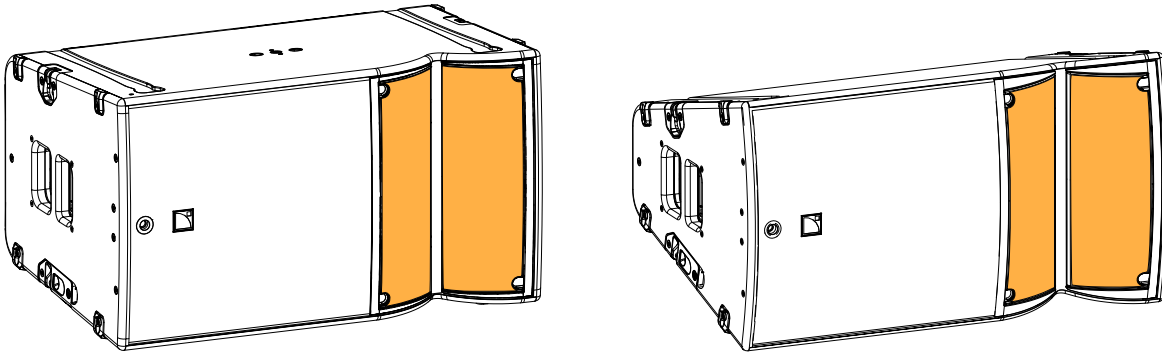

Within a line source, combine A15 Focus and A15 Wide with custom directivity settings to improve SPL mapping and throw capability.

### 110° setting

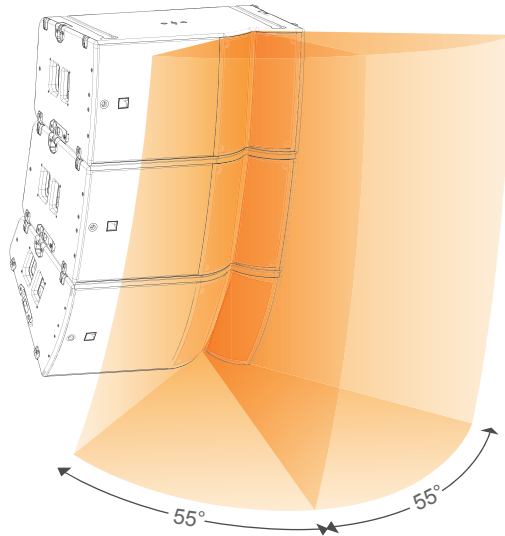
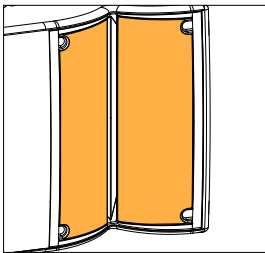

## 70° setting

Setting the fins in the 35° position offers an additional 2 dB on-axis (> 2 kHz).

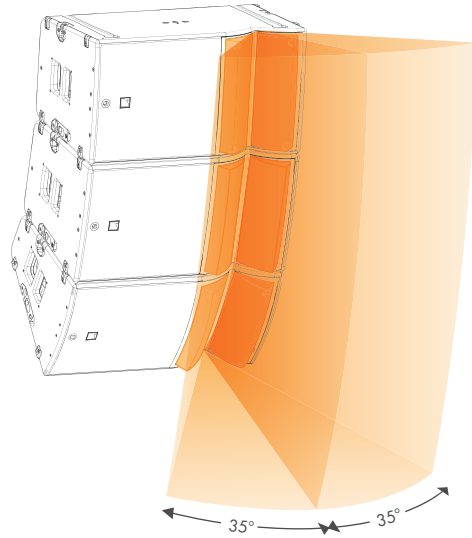
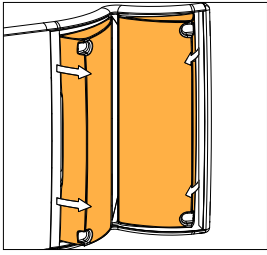

## 90° settings

Setting the fins in the 90° position offers an additional 1 dB on-axis (> 2 kHz).

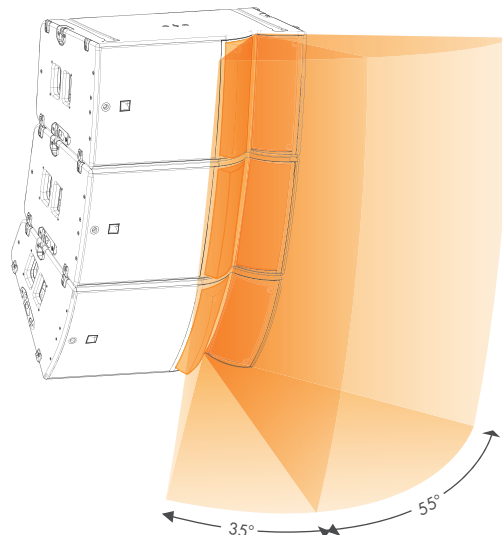
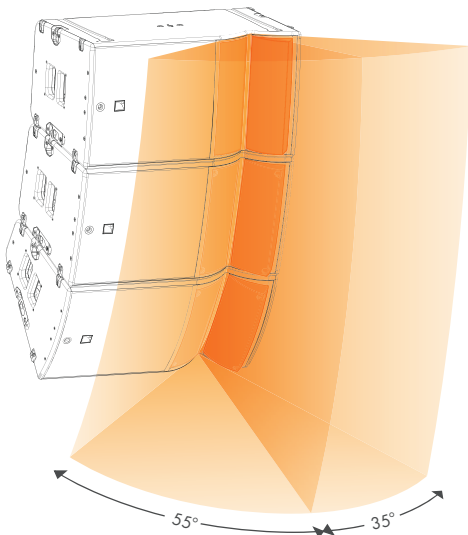
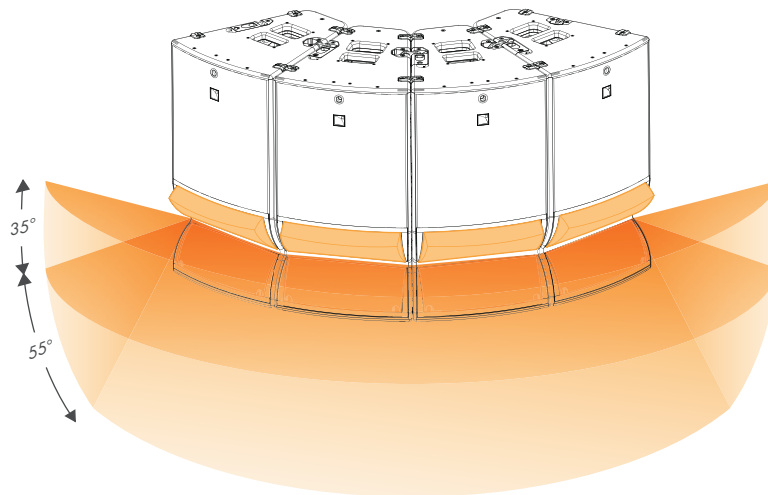
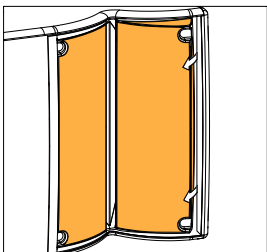
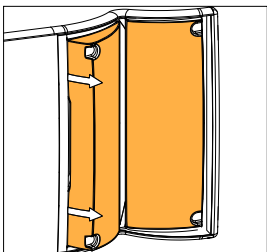

## Mixed settings

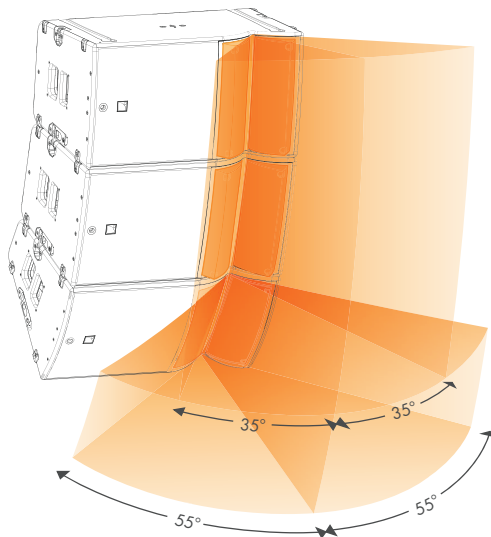

## Directivity

### A15 Focus

A15 Focus generates an enclosure directivity pattern of 10° and a waveguide directivity pattern of 70° / 110° symmetric or 90° asymmetric (-6 dB) depending on the fins settings.

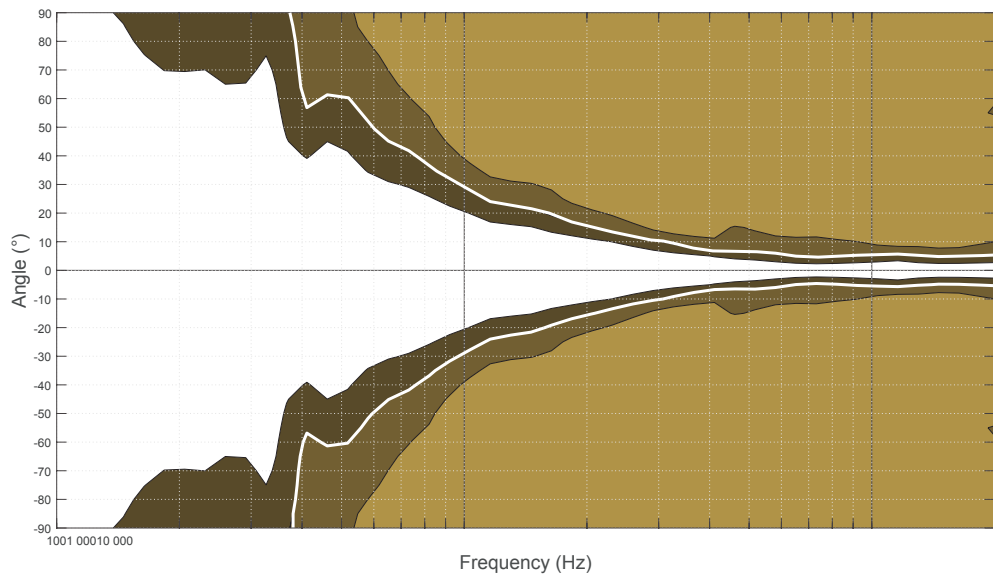
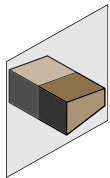

Dispersion angle diagram of one upright A15 Focus, using lines of equal sound pressure at -3 dB, -6 dB, -12 dB.

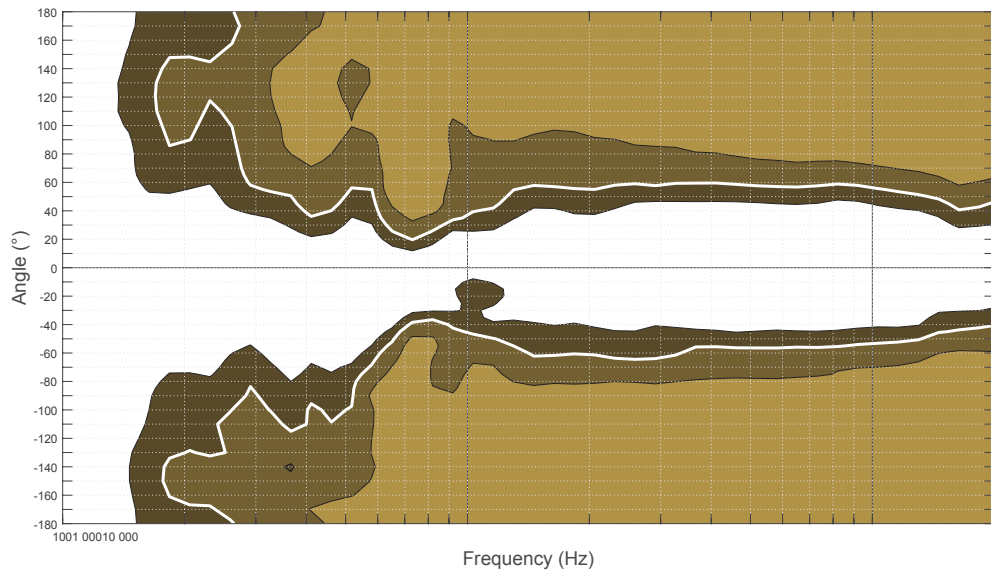
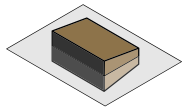

Dispersion angle diagram of one A15 Focus with 110° fins setting, using lines of equal sound pressure at -3 dB, -6 dB, -12 dB.

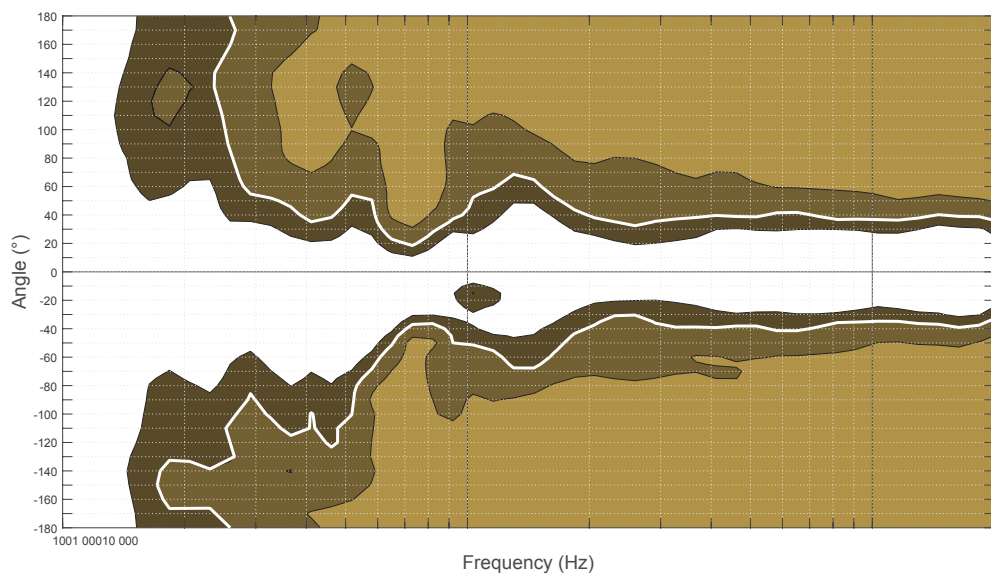
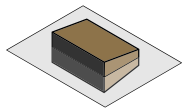

Dispersion angle diagram of one A15 Focus with 70° fins setting, using lines of equal sound pressure at -3 dB, -6 dB, -12 dB.

## A15 Wide

A15 Wide generates an enclosure directivity pattern of 30° and a waveguide directivity pattern of 70° / 110° symmetric or 90° asymmetric (-6 dB) depending on the fins settings.

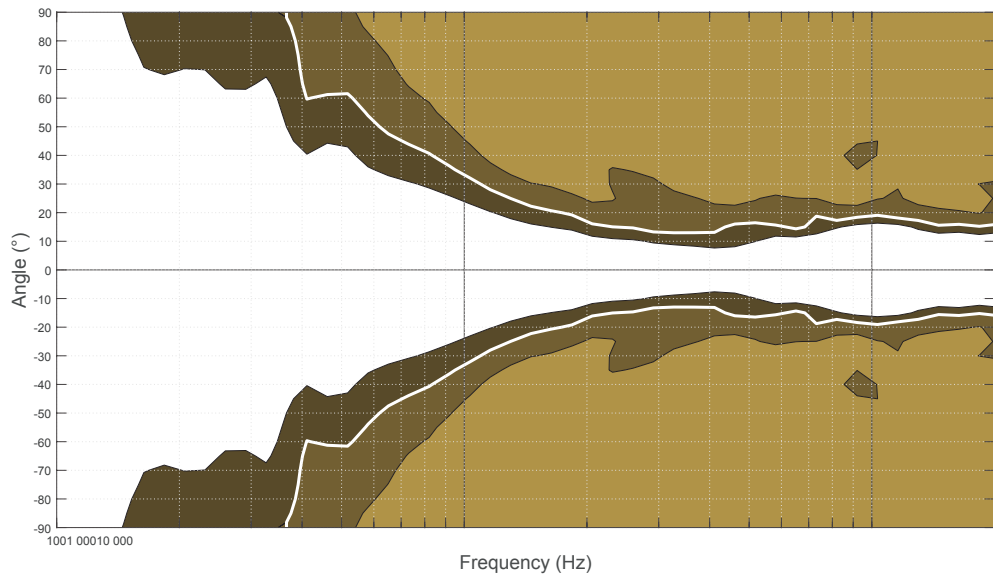
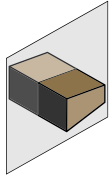

Dispersion angle diagram of one upright A15 Wide, using lines of equal sound pressure at -3 dB, -6 dB, -12 dB.

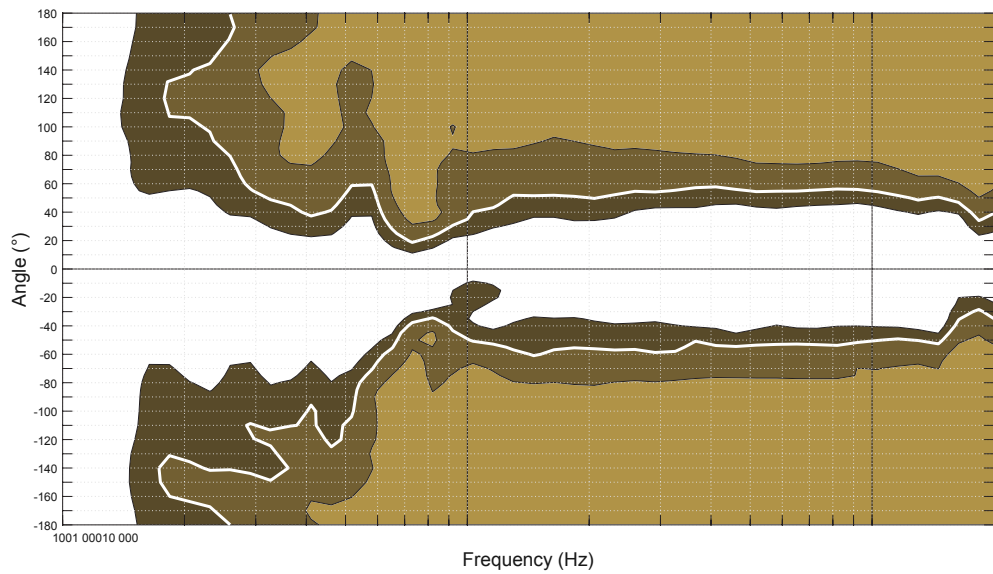
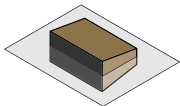

Dispersion angle diagram of one A15 Wide with 110° fins setting, using lines of equal sound pressure at -3 dB, -6 dB, -12 dB.



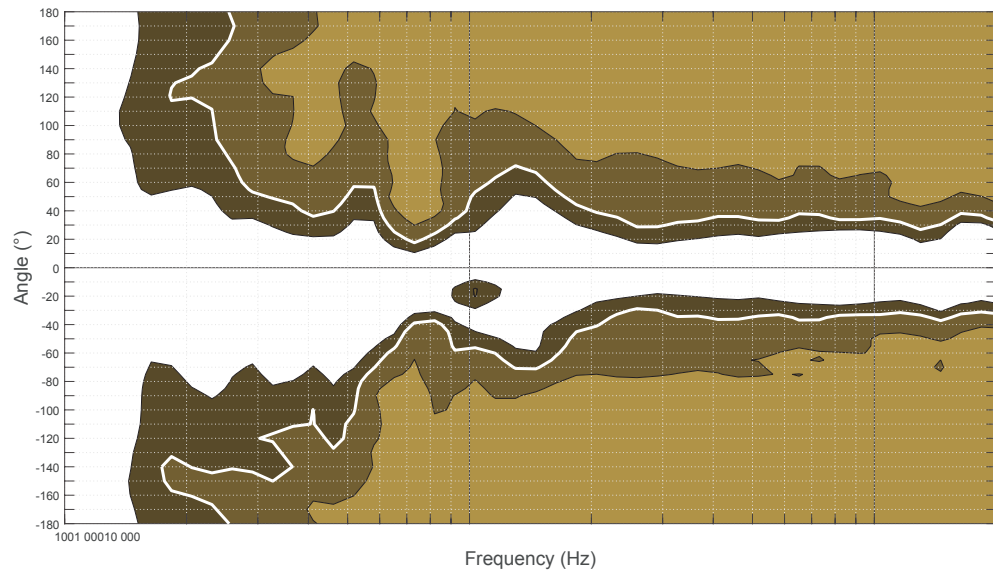
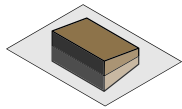

Dispersion angle diagram of one A15 Wide with 70° fins setting, using lines of equal sound pressure at -3 dB, -6 dB, -12 dB.

## Symmetrical configurations

The A15 rigging system is designed to enable a completely symmetrical setup for stereo applications.

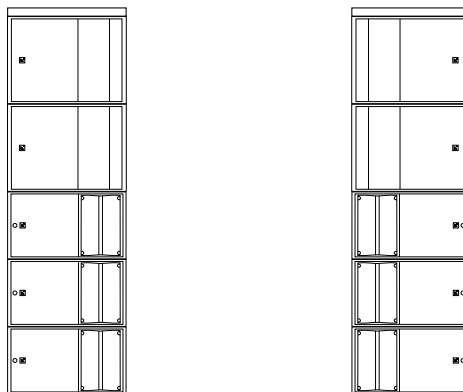

## Preset description

### [A15]

| outputs | channels | routing | gain | delay | polarity | mute |
|---------|----------|---------|------|-------|----------|------|
| OUT 1   | PA       | IN A    | 0 dB | 0 ms  | +        | ON   |
| OUT 2   | PA       | IN A    | 0 dB | 0 ms  | +        | ON   |
| OUT 3   | PA       | IN A    | 0 dB | 0 ms  | +        | ON   |
| OUT 4   | PA       | IN A    | 0 dB | 0 ms  | +        | ON   |

### [A15\_FI] [A15\_MO]

| outputs | channels | routing | gain | delay | polarity | mute |
|---------|----------|---------|------|-------|----------|------|
| OUT 1   | PA       | IN A    | 0 dB | 0 ms  | +        | ON   |
| OUT 2   | PA       | IN A    | 0 dB | 0 ms  | +        | ON   |
| OUT 3   | PA       | IN B    | 0 dB | 0 ms  | +        | ON   |
| OUT 4   | PA       | IN B    | 0 dB | 0 ms  | +        | ON   |

### [KS21\_60]

| outputs | channels | routing | gain | delay | polarity | mute |
|---------|----------|---------|------|-------|----------|------|
| OUT 1   | SB       | IN A    | 0 dB | 0 ms  | +        | ON   |
| OUT 2   | SB       | IN A    | 0 dB | 0 ms  | +        | ON   |
| OUT 3   | SB       | IN A    | 0 dB | 0 ms  | +        | ON   |
| OUT 4   | SB       | IN A    | 0 dB | 0 ms  | +        | ON   |

### [KS21\_60\_C] [KS21\_60\_Cx]

| loudspeaker elements | outputs | channels | routing | gain | delay | polarity | mute |
|----------------------|---------|----------|---------|------|-------|----------|------|
| SR                   | OUT 1   | SR       | IN A    | 0 dB | 0 ms  | +        | ON   |
| SB                   | OUT 2   | SB       |         |      |       |          | ON   |
| SB                   | OUT 3   | SB       |         |      |       |          | ON   |
| SB                   | OUT 4   | SB       |         |      |       |          | ON   |

## Connectors



SpeakON connectors can be used interchangeably as IN or LINK connector.

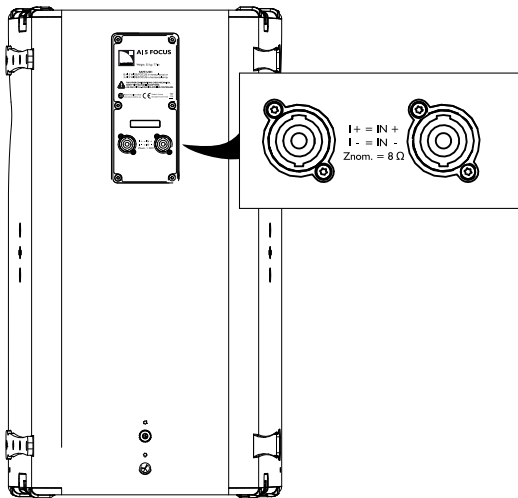

A15 Focus

2 × 4-point speakON

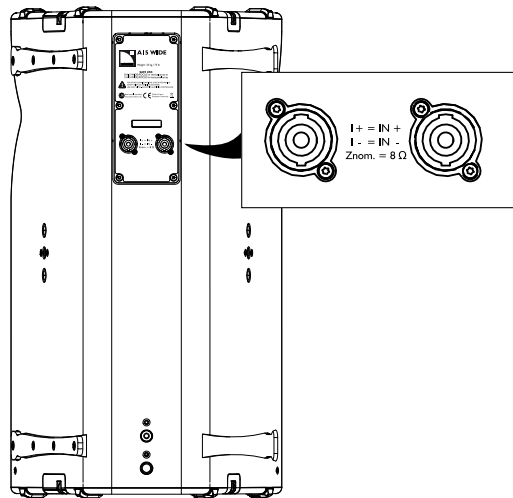

A15 Wide

2 × 4-point speakON

### Internal pinout for L-Acoustics 2-way passive enclosures

| SpeakON points        | 1 + | 1 - | 2 +        | 2 -        |
|-----------------------|-----|-----|------------|------------|
| Transducer connectors | +   | -   | Not linked | Not linked |

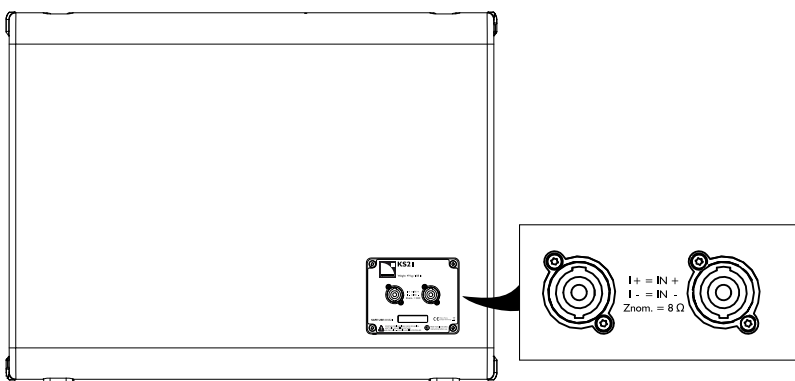

KS21

2 × 4-point speakON

### Internal pinout for L-Acoustics subwoofers

| SpeakON points        | 1 +  | 1 -  | 2 +        | 2 -        |
|-----------------------|------|------|------------|------------|
| Transducer connectors | LF + | LF - | Not linked | Not linked |

## Rigging system description

### A15 system rigging

A15 Wide/Focus and KS21 feature the same rigging system consisting of two elements:

- A rotating rigging arm.
- A spring-loaded pin.

**i** Push and slide to unlock the spring-loaded pin.

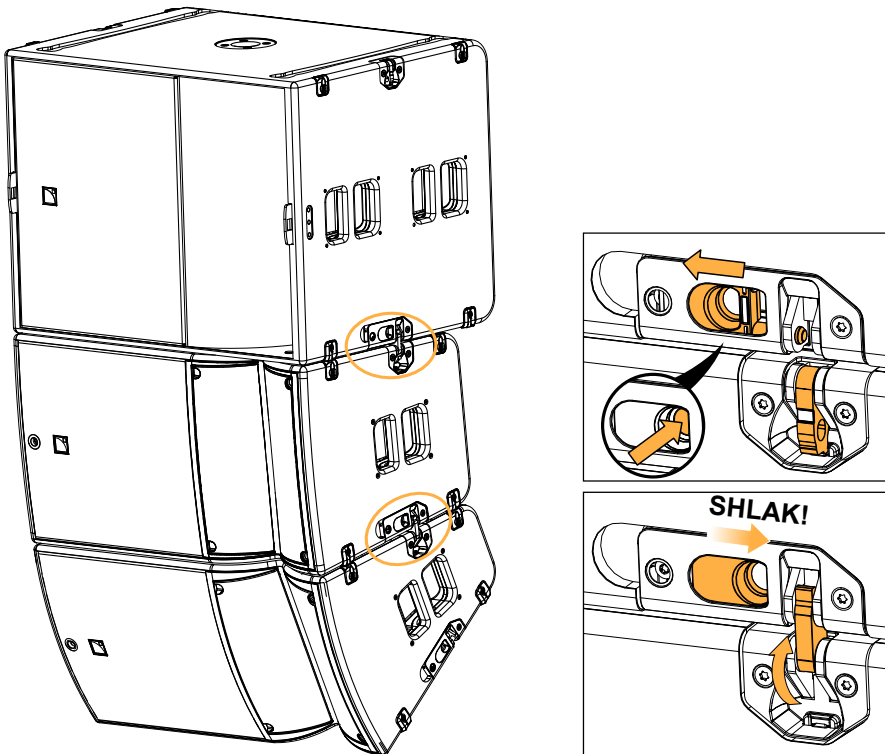

The rigging elements are fitted with yellow safety labels that are visible when they are not safely locked.

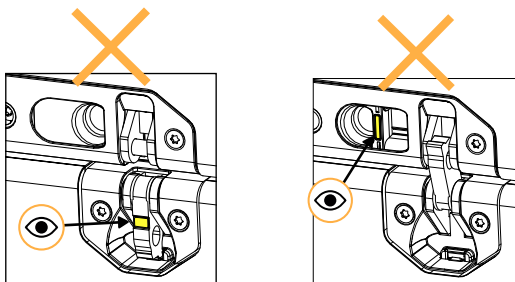

Each enclosure displays two ground runners on the bottom and two matching tracks on the top.

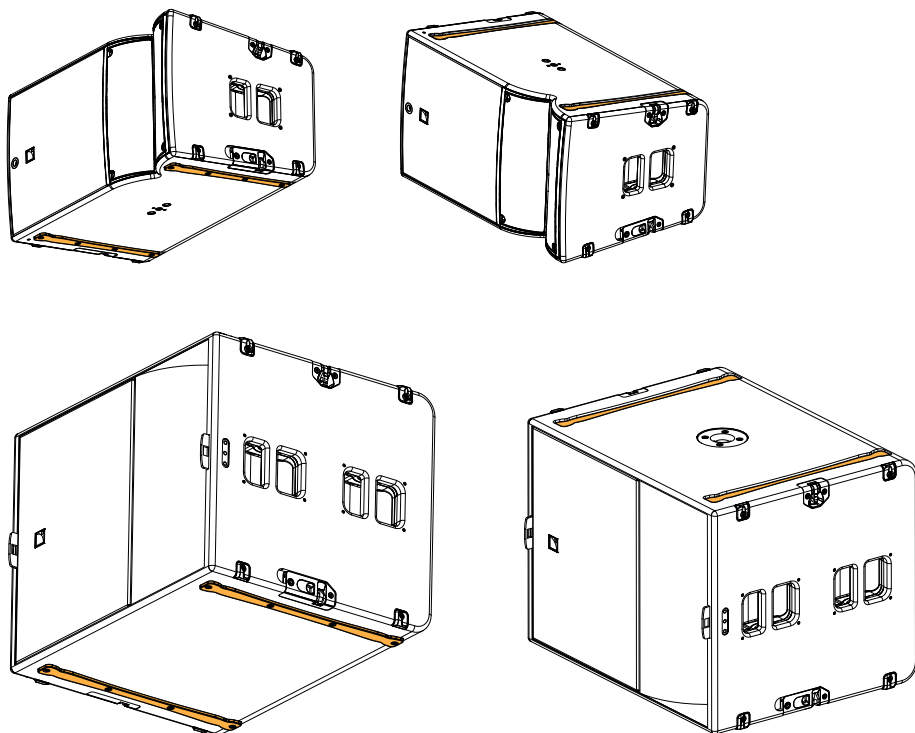

Eight corner stops protect the side panels during handling.

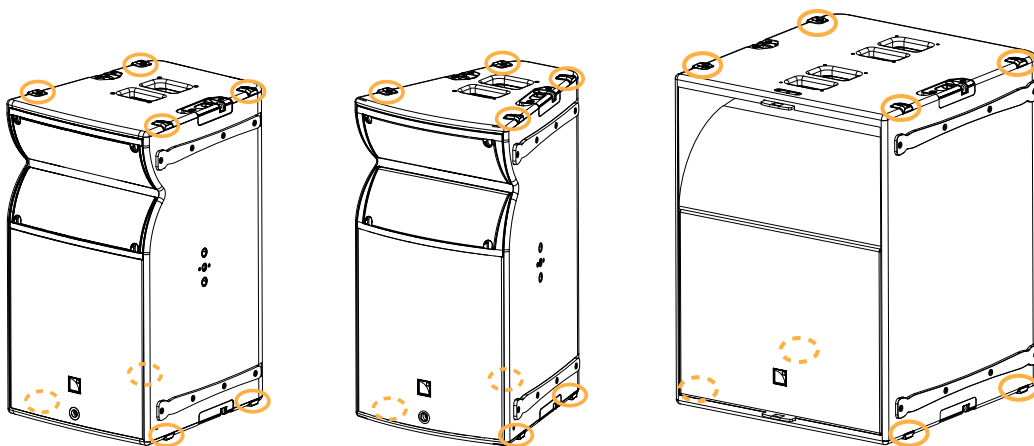

The logo on the enclosure front can be rotated to adapt to every configuration.

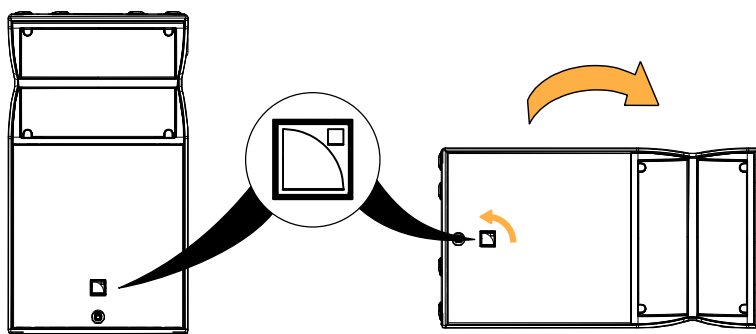

## Enclosures

### A15 Wide/Focus

A15 Wide/Focus feature two lodgings to create radial arrays with [A15-LIFT](#) (p.31).

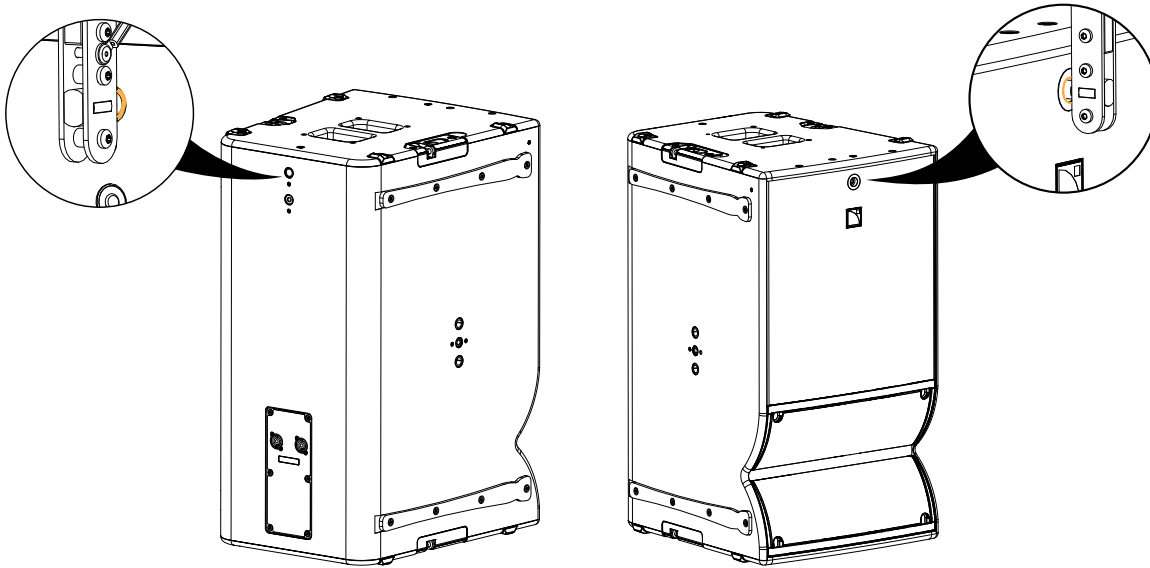

A DIN580-compatible M8 threaded insert is available to implement a secondary safety.

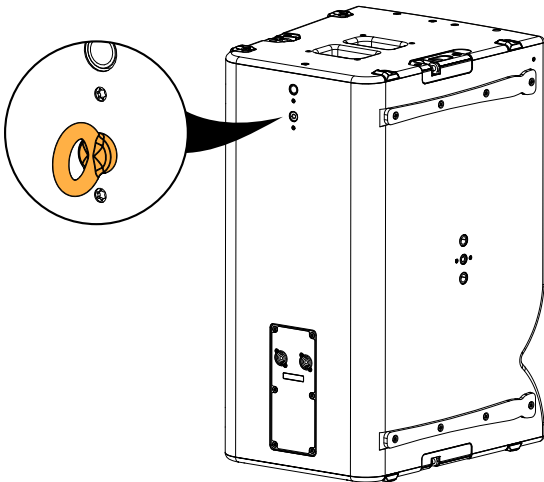

Two sets of two lodgings and one insert provide further options for flying, stacking or pole-mounting a single enclosure or small arrays with [X-BAR](#) (p.40), [A-TILT](#) (p.34), or [A-MOUNT](#) (p.39), respectively.

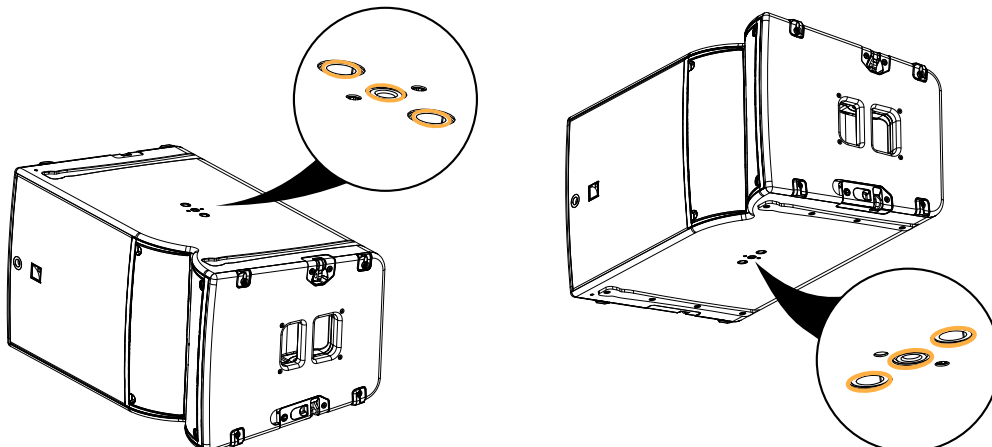

Two ergonomic handles are available for transportation.

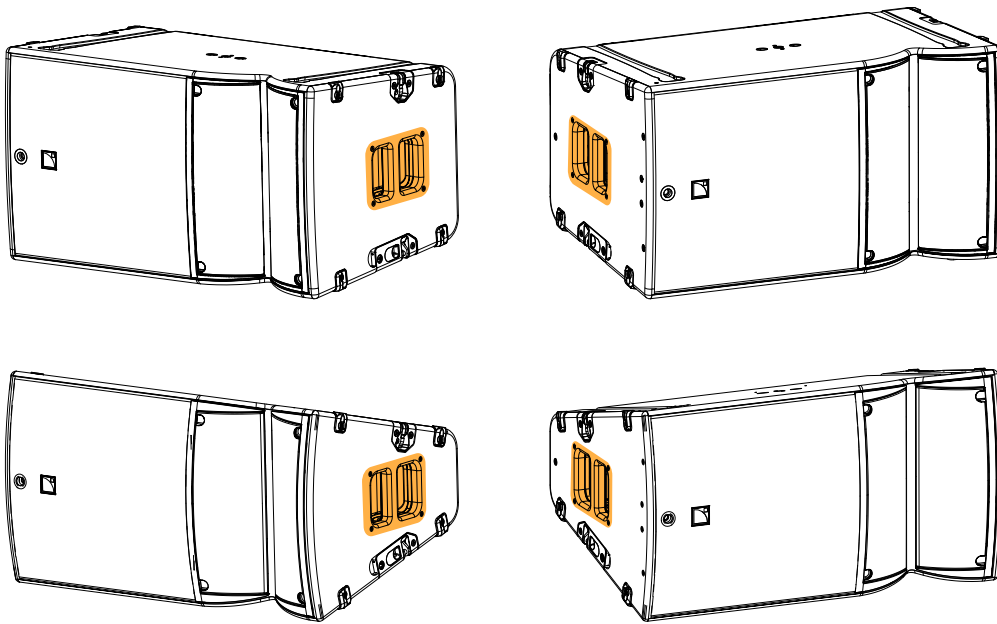

## KS21

KS21 features a 35 mm pole-socket which contains an M20×150 insert.



### Use a 35 mm diameter pole

The pole can be non-threaded or with M20 thread.

Use an adapter for poles with other dimensions, for example the 21329 adapter by K&M, available on [www.k-m.de/en](http://www.k-m.de/en).

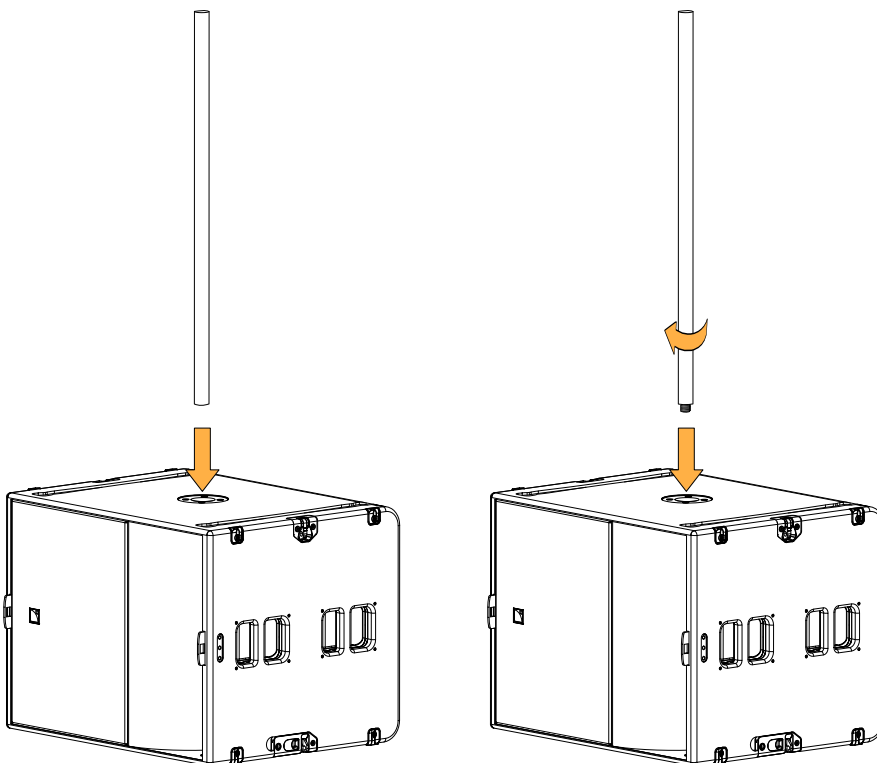

Four handles are available for transportation.

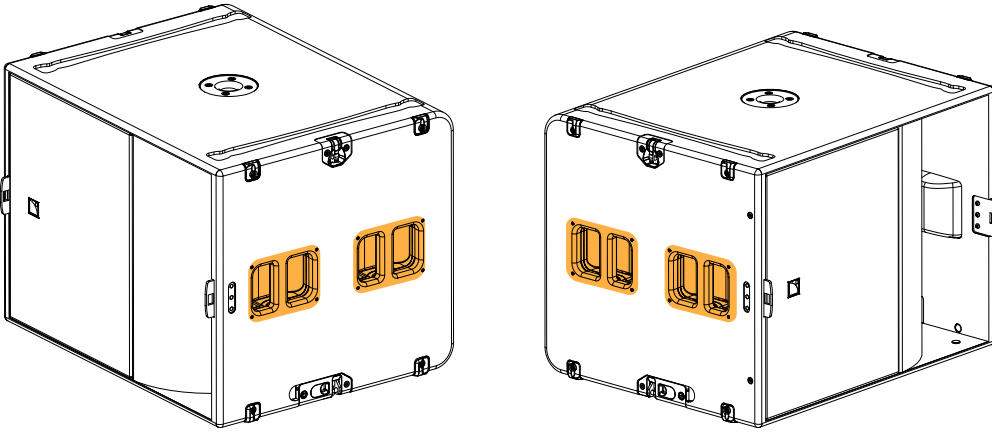

**! Dedicated chariot and dolly board for KS21**

KS21 is intended for use only with L-Acoustics KS21-CHARIOT and KS21-PLA.  
Use with other equipment may result in instability causing injury.

**Rigging elements for flown arrays**

**A15-BUMP**

A15-BUMP is a reversible rigging frame for flying vertical arrays of A15 Wide/Focus or KS21.

A15-BUMP is equipped with rotating rigging arms and ball-locking pins, to match the rigging systems of A15 Wide/Focus or KS21 on either side.

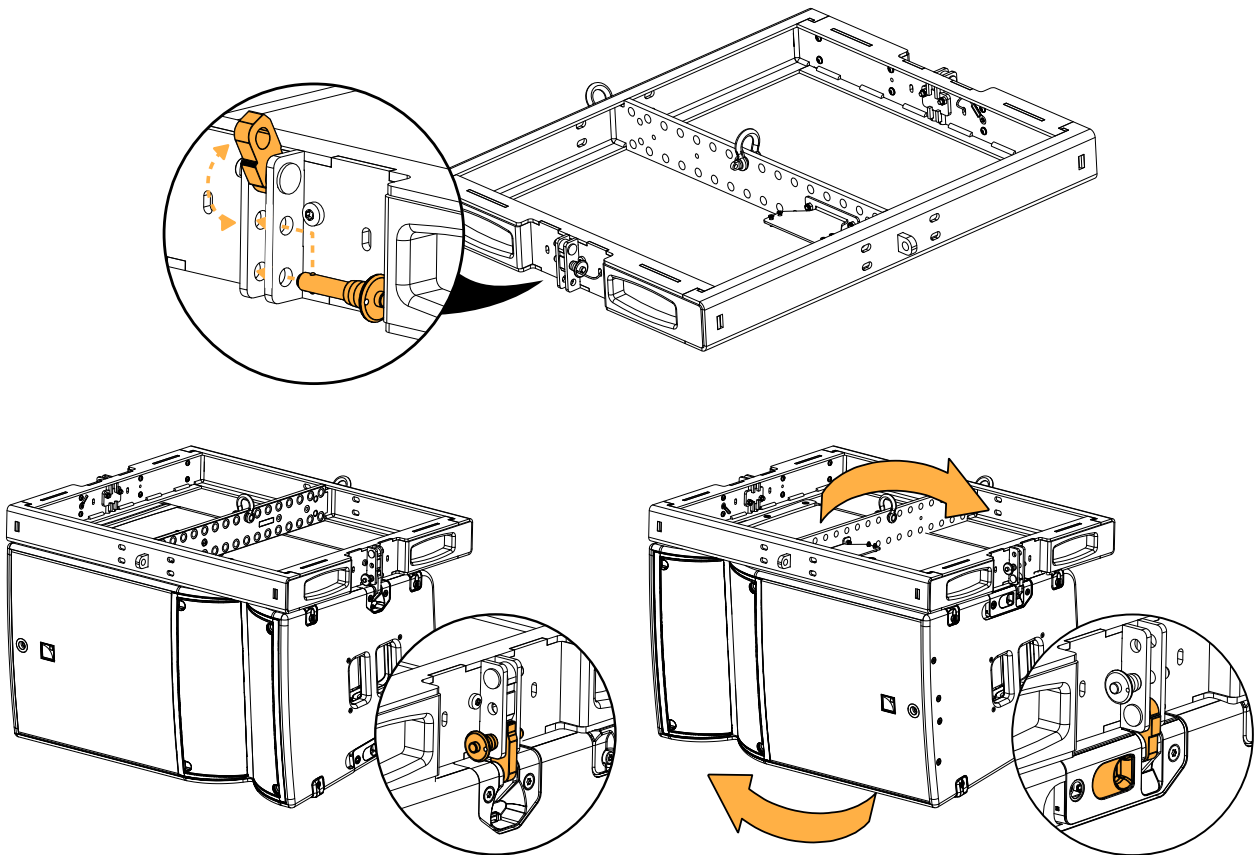



The rigging arms are fitted with yellow safety labels, that are visible when the rigging arm is not in use.

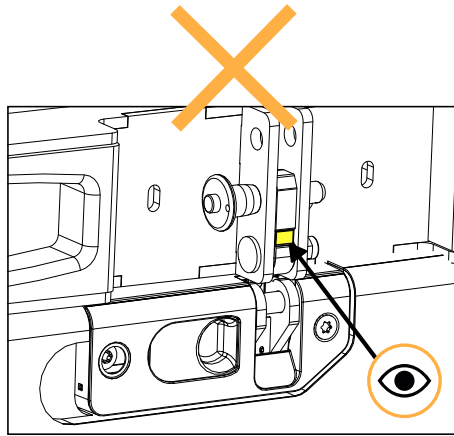

16 pickup points on each side, one front pickup point (F), and one rear pickup point (R), are available for site angle adjustments. They are compatible with Ø12 mm shackles WLL 1 t (two provided) and CLAMP250.

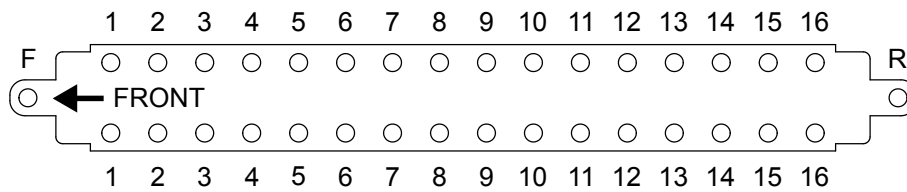

A15-BUMP can be used as the main lifting accessory for flying vertical arrays of A15 Wide/Focus and KS21 with one or two lifting points.

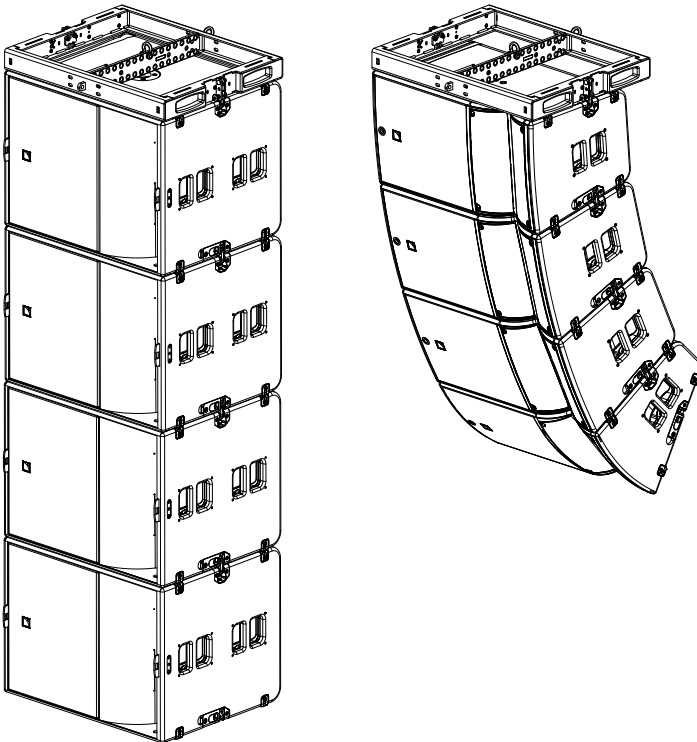

A15-BUMP can be secured to the bottom of the array to implement pullback configurations, using the rear pickup point (R). Alternatively, [A15-RIGBAR](#) (p.29) can be used for pullback.

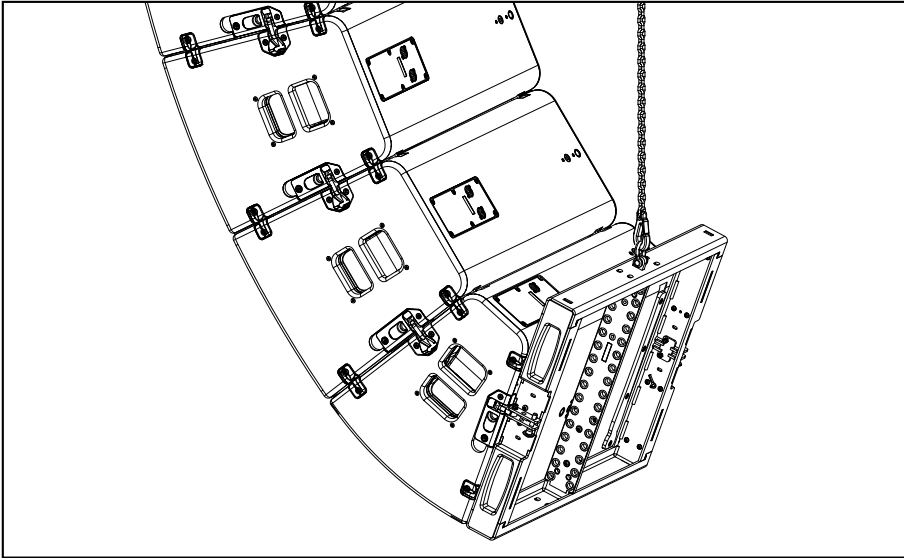

A laser mounting plate is available. Refer to [APPENDIX B: Installing the LAP-TEQ inclinometer on A15-BUMP](#) (p.152).

### M-BAR

The M-BAR extension bar can be secured on A15-BUMP to extend the site angle capability of A15 Wide/Focus and KS21 arrays. It can be used as a front or rear extension.

M-BAR is secured to the rigging frame with two T-shaped 3/8" ball-locking pins.

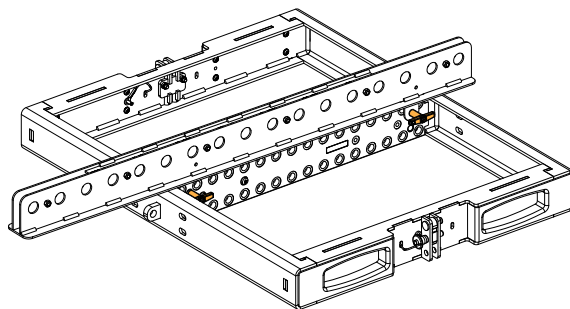
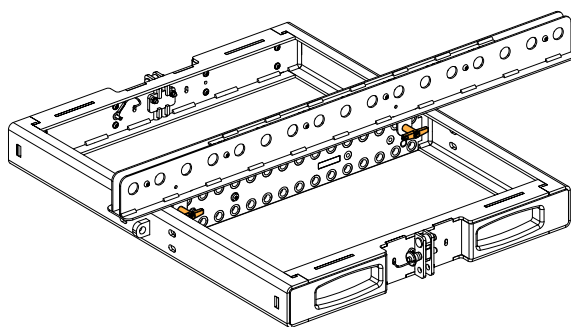
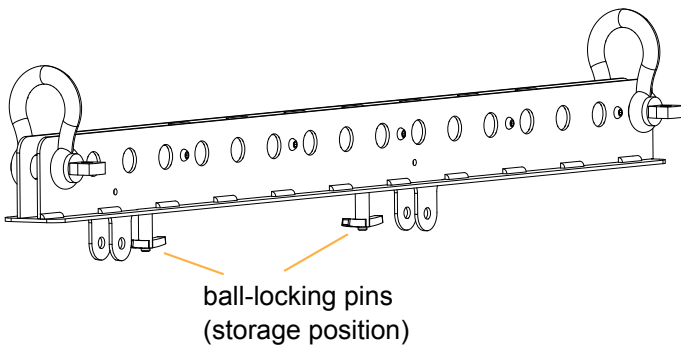

17 pickup points are available. They are compatible with Ø19 mm shackles WLL 3.25 t (two provided).

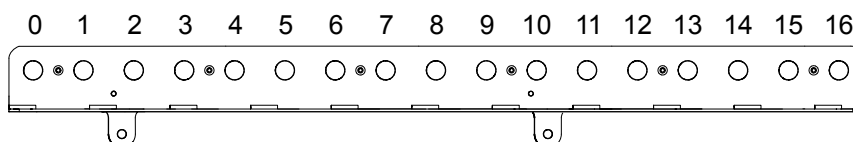

## A15-RIGBAR

A15-RIGBAR is a reversible rigging bar. It can be used as a pullback or for flying vertical arrays of up to four A15 Wide/Focus or KS21.

A15-RIGBAR is equipped with rotating rigging arms and ball-locking pins, to match the rigging systems of A15 Wide/Focus or KS21 on either side.

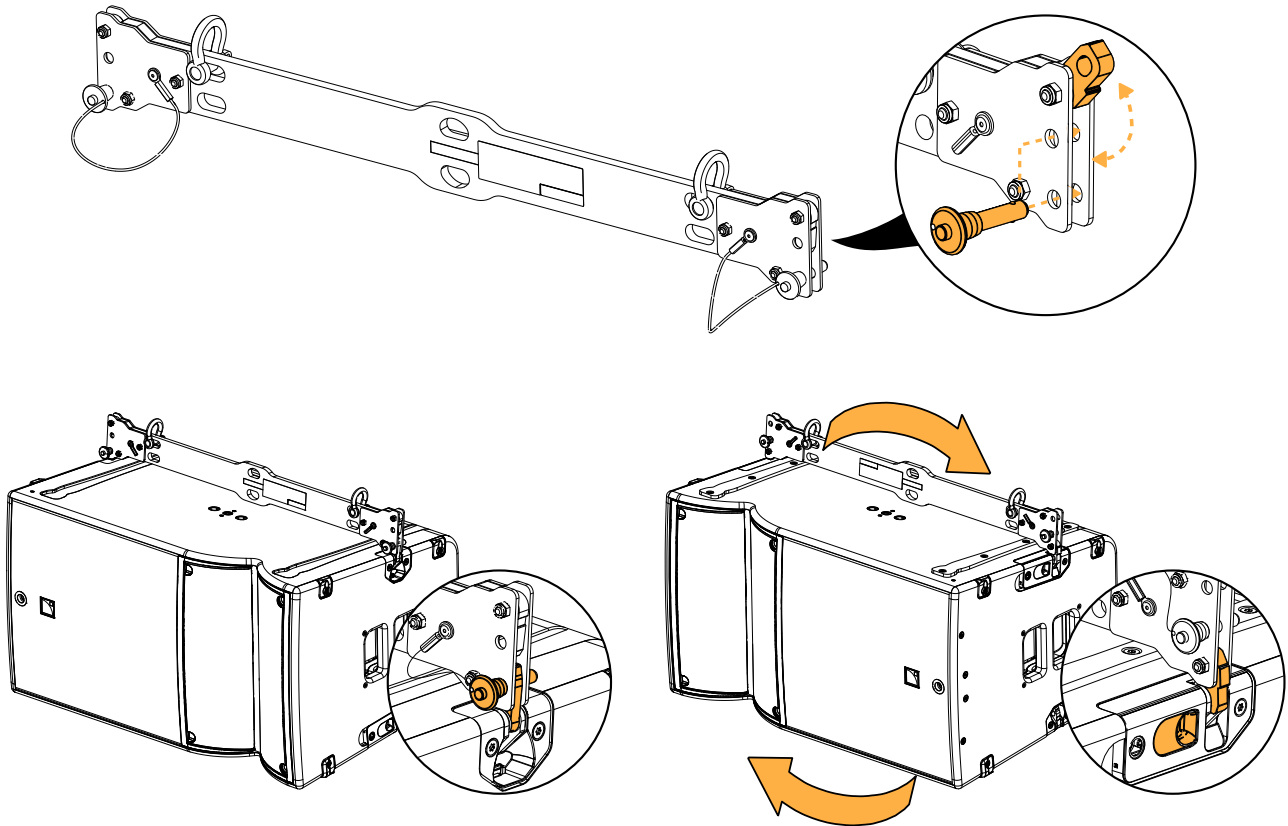

The rigging arms are fitted with yellow safety labels, that are visible when the rigging arm is not in use.

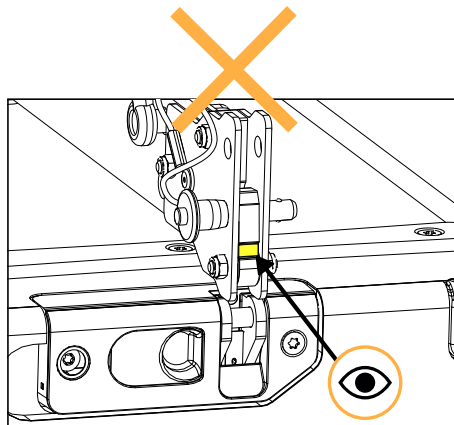

Secured at the bottom of the array, A15-RIGBAR can be used as a pullback either with A15-BUMP or another A15-RIGBAR as the main lifting accessory.

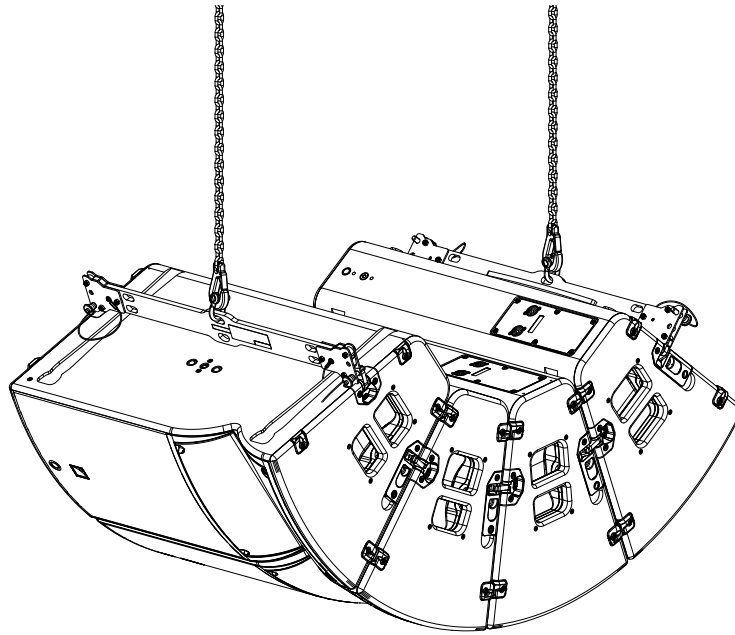

A15-RIGBAR can be used as the main lifting accessory, to provide a lightweight solution for flying four A15 Wide/Focus or KS21 with one or two lifting points.

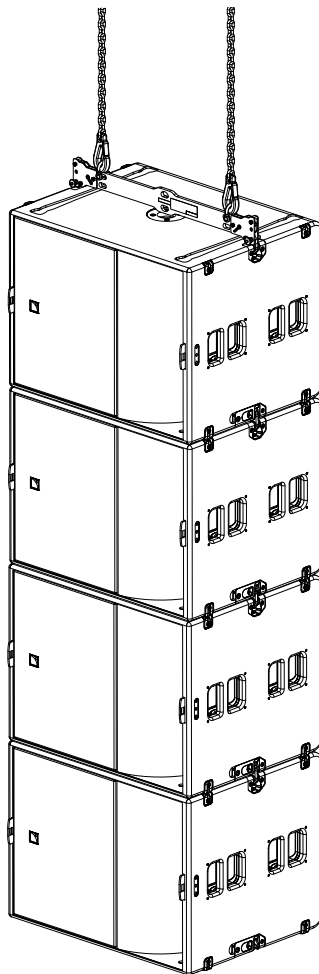

The pickup points are compatible with Ø12 mm shackles WLL 1 t (two provided) and CLAMP250.

**!** When using A15-RIGBAR as the main lifting accessory, always implement a secondary safety using available holes.

**One pickup point**

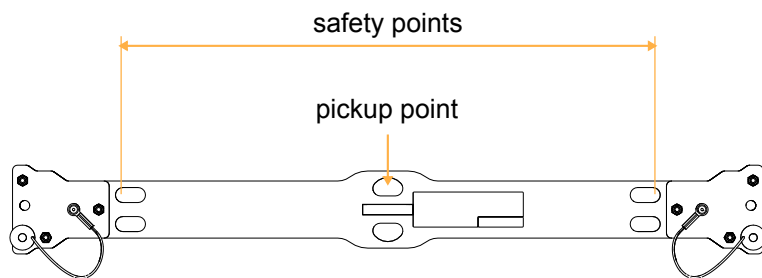

**Two pickup points**

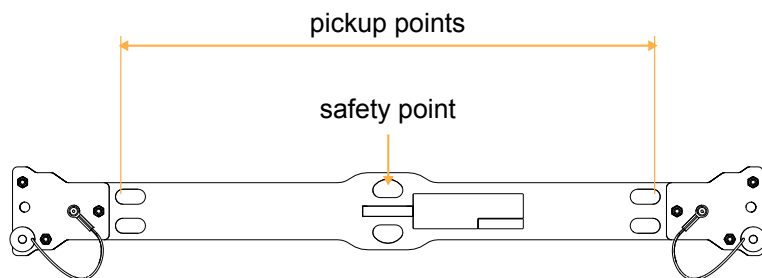

**A15-LIFT**

A15-LIFT is a rigging element designed to fly a radial array of up to three A15 Wide/Focus.

A15-LIFT features two studs that match the lodgings at the front and rear of the enclosure.

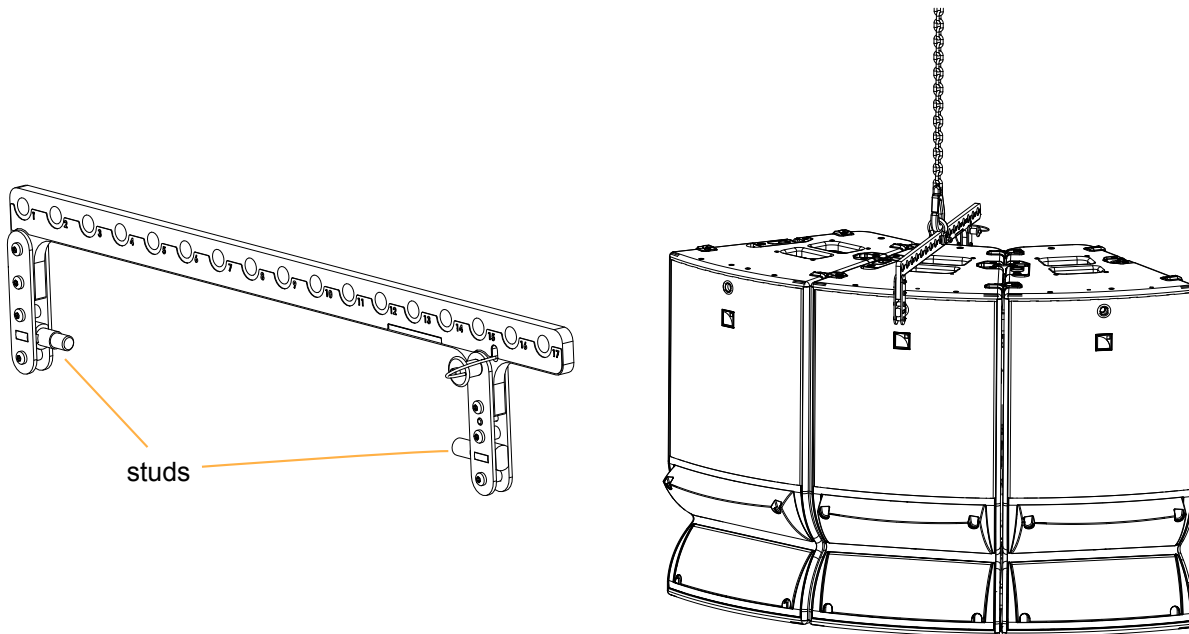

**! Additional safety with A15-LIFT**

On each enclosure on which A15-LIFT is secured, secure a DIN580 eye bolt to the dedicated insert to implement a secondary safety.

Use a shackle and a steel wire rope. Make sure the steel rope is as tensed as possible without bearing the load.

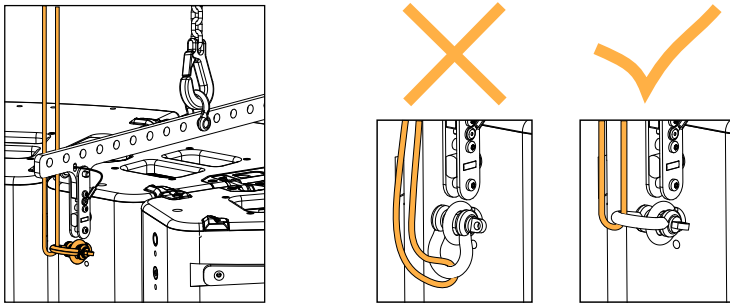

A scalable radial array of A15 Wide/Focus can be created using multiple A15-LIFT.

**! A15-LIFT quantity and position**

Use one A15-LIFT for up to three enclosures in the array.

Do not leave more than two adjacent enclosures unsupported.

Refer to [APPENDIX A: Authorized configurations with A15-LIFT](#) (p.150).

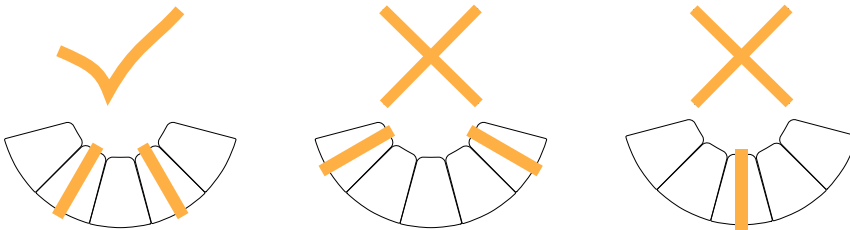

**! Risk of tilting**

When using a single motor or a bridle, make sure the array is symmetrical.

**!** When using a third-party bridle, make sure the angle between the two chains does not exceed 60°.

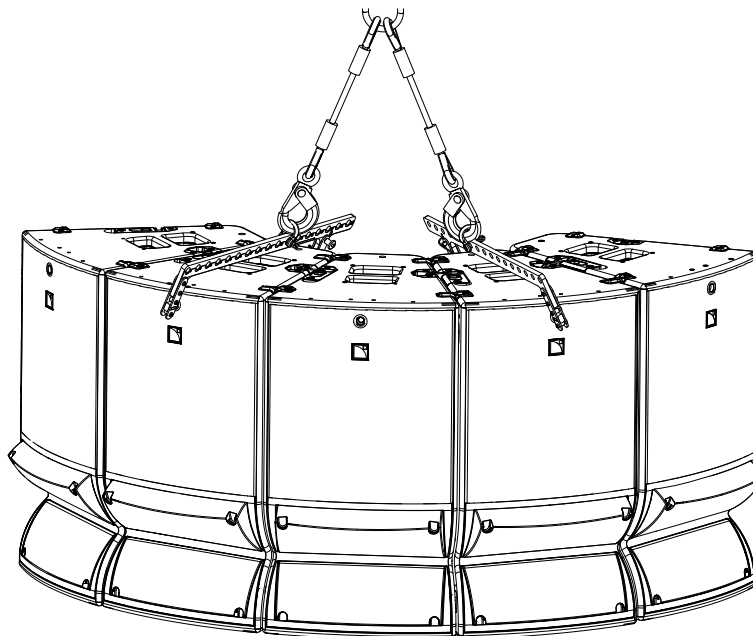

17 holes are available for site angle adjustment. They are compatible with  $\varnothing 12$  mm shackles WLL 1 t (two provided) and CLAMP250.



### A15-LIFT pickup point

Select the same pickup point on each A15-LIFT within an array of up to 6 enclosures.  
For larger arrays, refer to [Radial arrays of 7 enclosures and more](#) (p.151).



Hole 11 serves as a setup point in the radial array procedure (see [Flying a radial array with A15-LIFT](#) (p.86)).  
It is identified by a mark on the label.

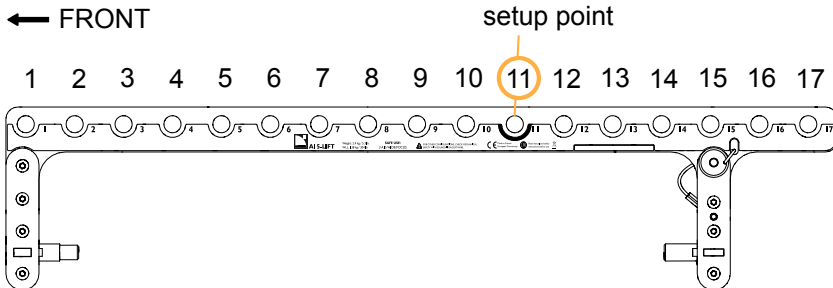

## Rigging elements for stacked arrays

### A-TILT

A-TILT is a site angle adjustment accessory that interfaces between KS21 and A15 Wide/Focus in a stacked array. It is used in combination with two KS21-OUTRIG\* under KS21 to ensure stability.

**i** \* Alternatively, mount the KS21 array on KS21-CHARIOT and use K2-JACK to stabilize the array. Refer to [Attaching K2-JACK stabilizers to KS21-CHARIOT](#) (p.101).

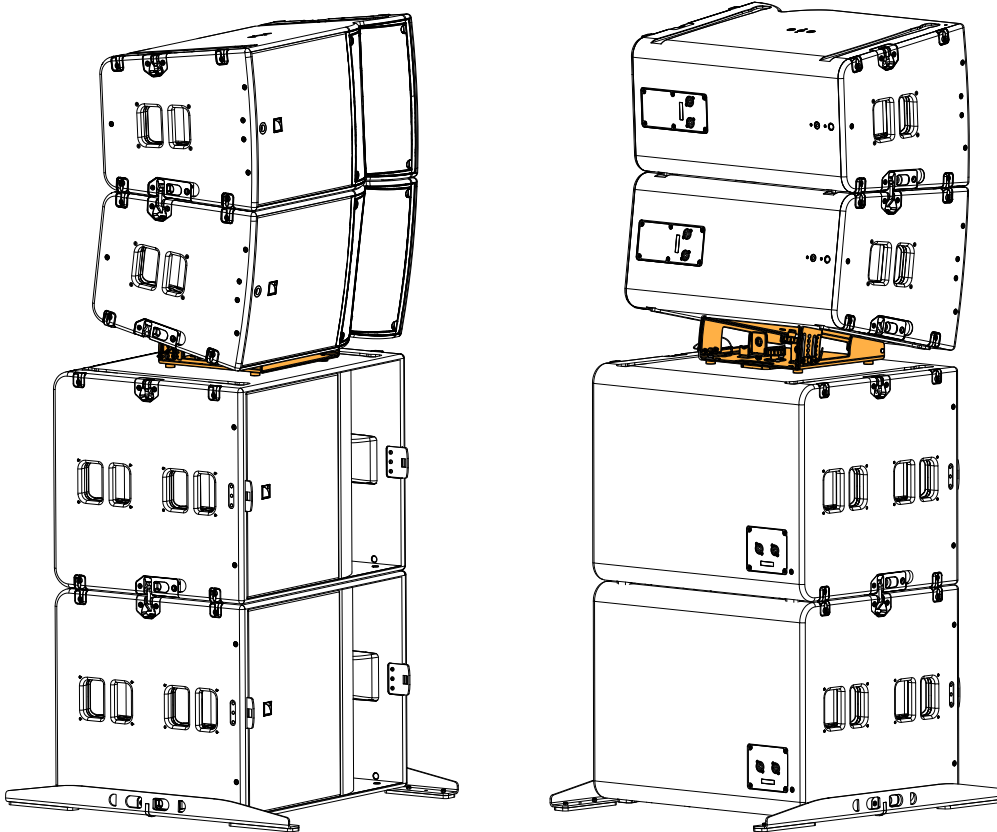

**!** Do not use A-TILT in a flown array.

The locating pins on A-TILT match the lodgings on the enclosure, to enable deployments with the HF section on either side. A-TILT is secured to the enclosure and to the subwoofer with threaded knobs.

**!** A-TILT-compatible subwoofers  
The A-TILT subwoofer knob can only be used with KS21.

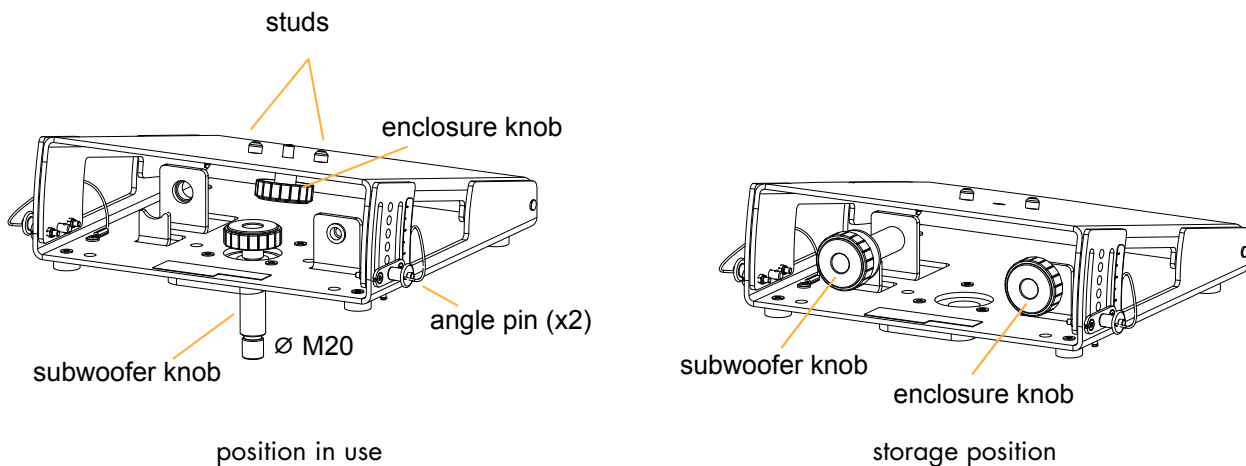



The opening angle of A-TILT can be adjusted between 12.5° and 25°.

The label displays the opening angle of the accessory and not the site angle of the enclosure. Refer to [Stacking A15 Wide/Focus on KS21 with A-TILT](#) (p.95) for the list of realized site angles.

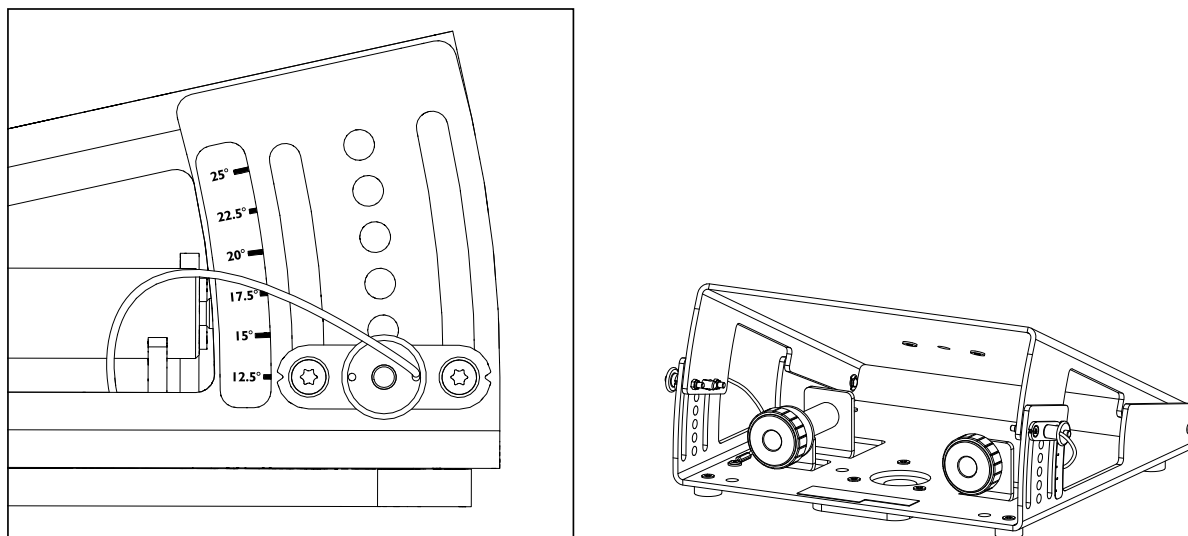

Four Ø11 mm holes are available to secure the assembly to the floor.

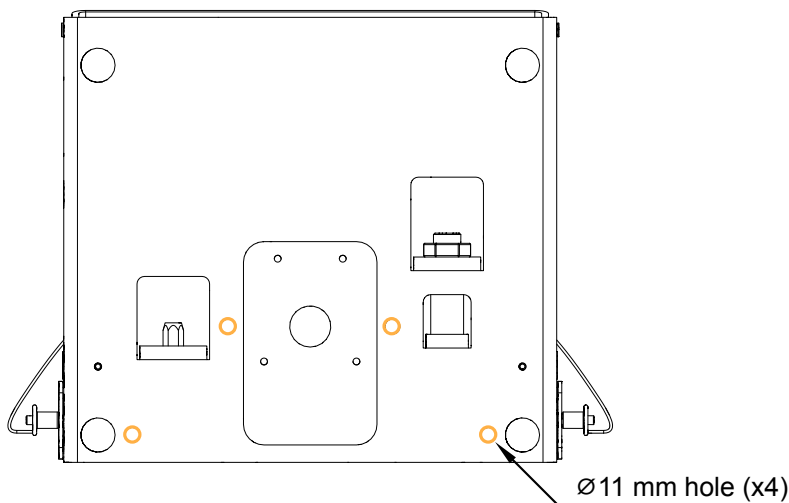

## KS21-OUTRIG

KS21-OUTRIG is a set of two stability bars for KS21. Secure KS21-OUTRIG at the bottom of a KS21 array to improve the stability of the array. The use of KS21-OUTRIG is mandatory when A15 Wide/Focus are stacked on top of KS21.

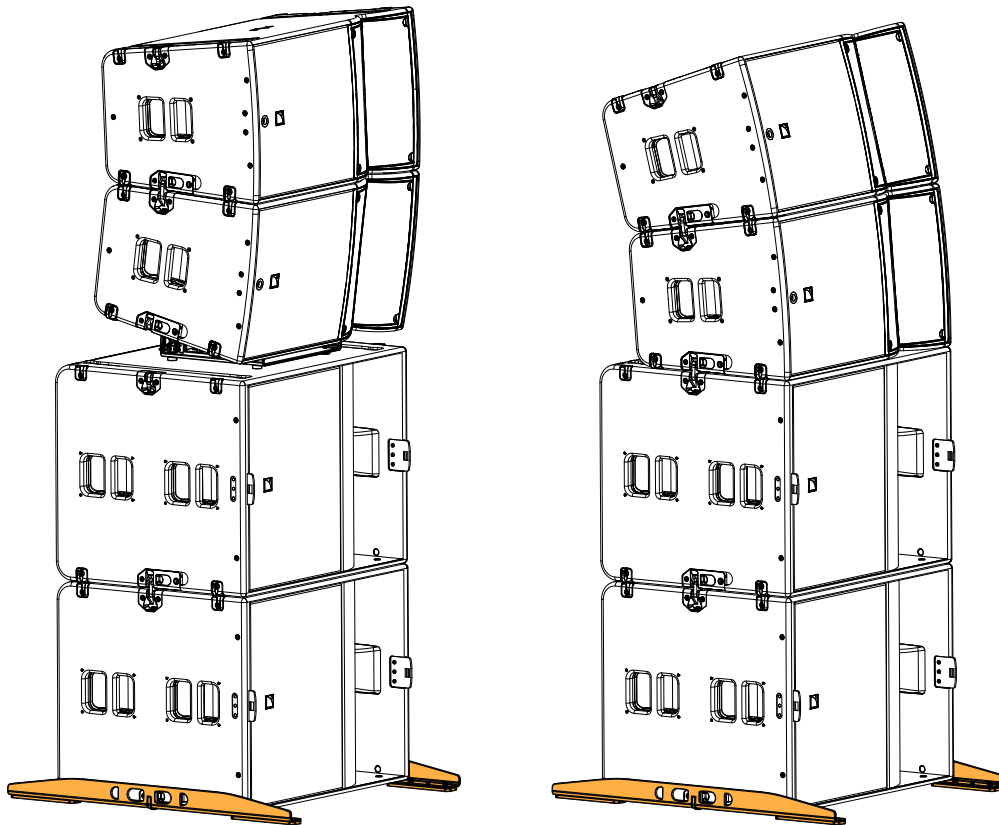

KS21-OUTRIG matches the rigging system of KS21.

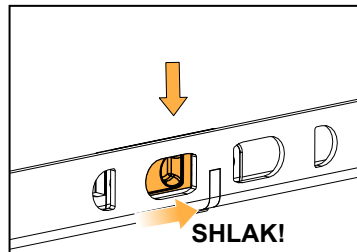
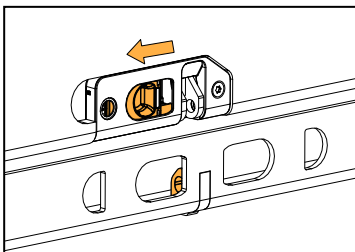

Two runners on each KS21-OUTRIG bar ensure stability. Four Ø 6.5 mm holes are available to secure the assembly to the floor.

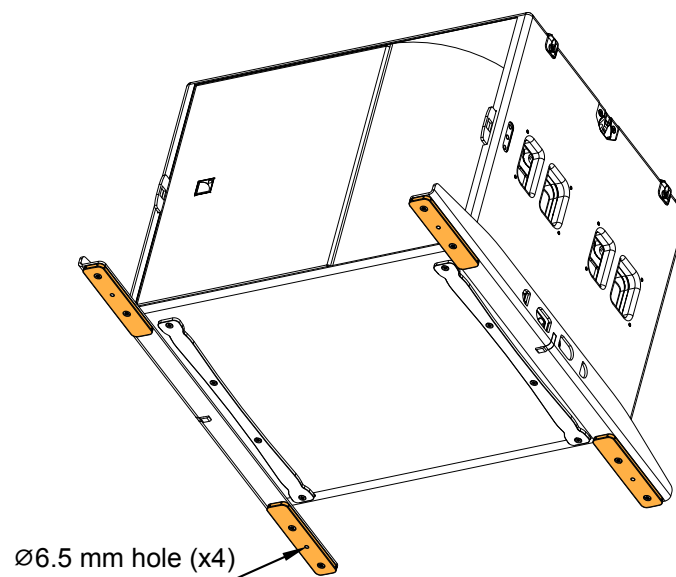

## K2-JACK

K2-JACK is a set of two bars and four feet with screw jacks and hand wheels. K2-JACK can be fitted onto [KS21-CHARIOT](#) (p.42) to improve stability or correct floor discrepancies.

**i** During transportation, make sure the bolts are tightened.

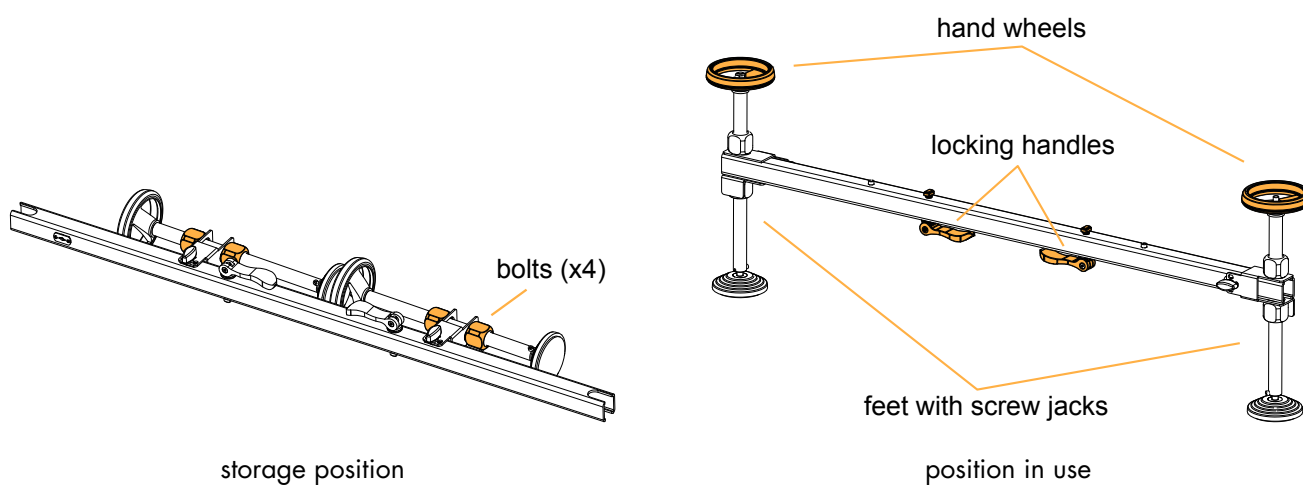

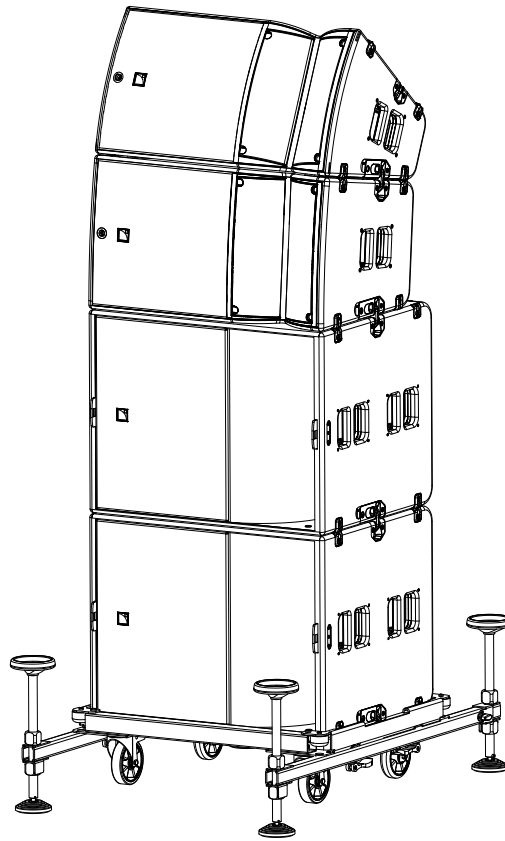

## Rigging elements for a single enclosure

### A-MOUNT

A-MOUNT is a 35 mm (1-3/8") pole-mount adapter for a single A15 Wide/Focus.

A-MOUNT is secured to the enclosure with a threaded knob and tightened onto the pole with a wedge clamp. Two locating pins match the lodgings on the enclosure. A-MOUNT features two axis: the front one can be moved to change the site angle.

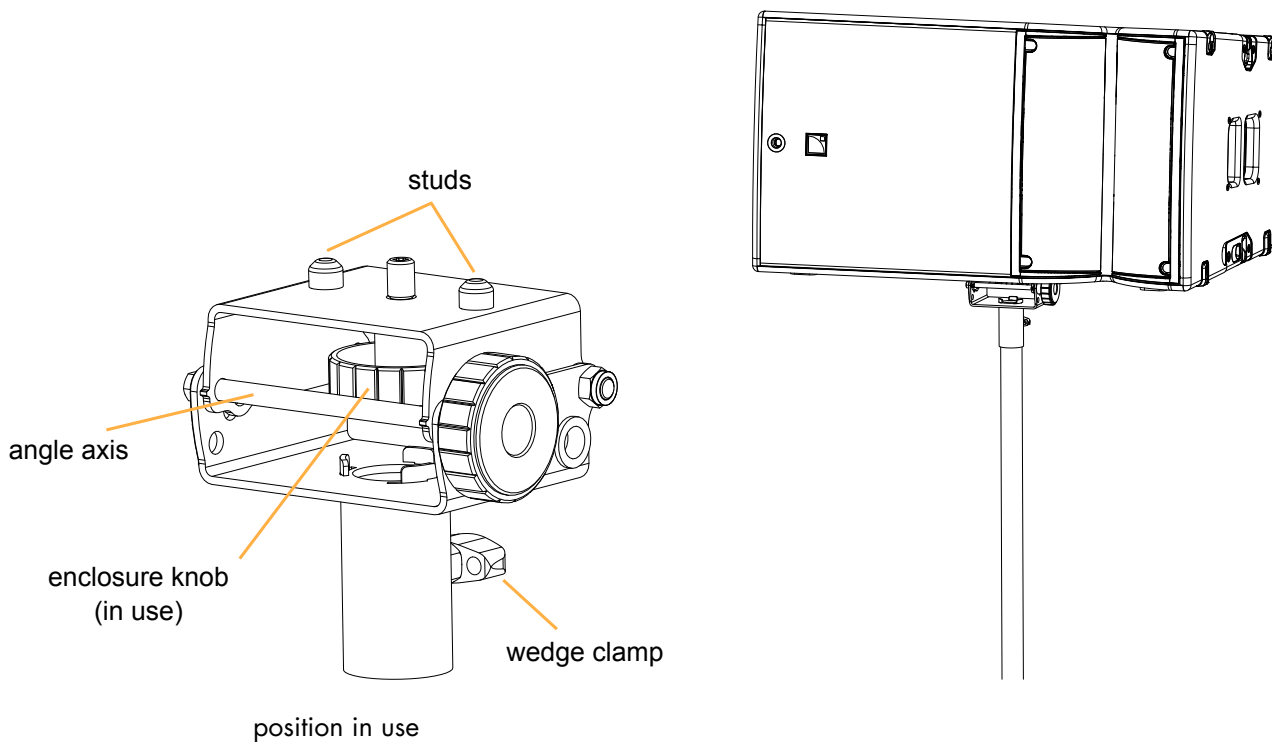

The enclosure knob can be stored in an insert on the side.

The angle axis is secured with a threaded knob. To optimize visual impact, the knob can be replaced by a locking cotter pin (provided).

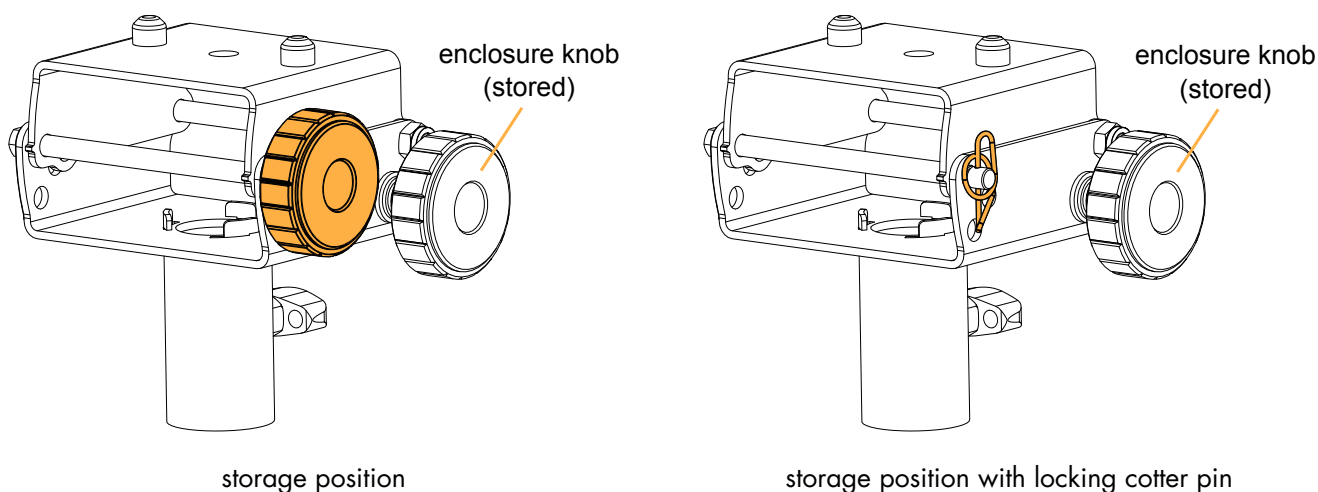

The opening angle can be set to 0°, -5° and -15°.

Refer to [Pole-mounting A15 Wide/Focus](#) (p.104) for the list of realized site angles.

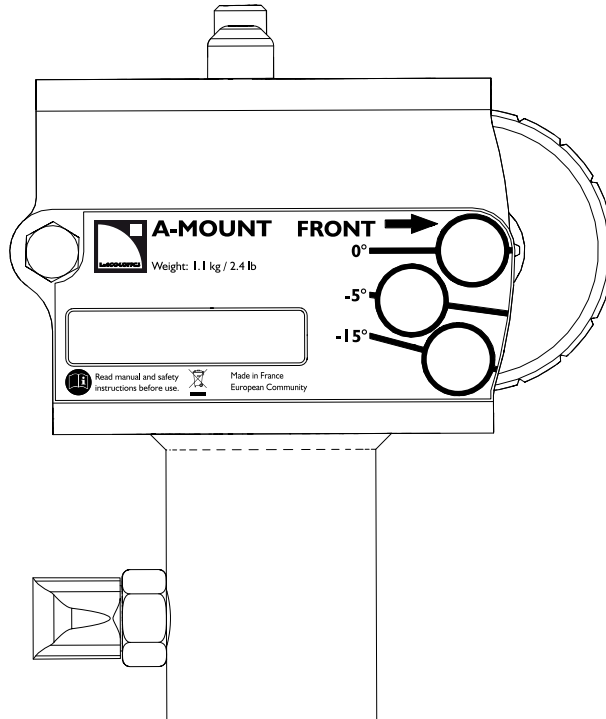

## X-BAR

X-BAR is a rigging bar for flying A15 Wide/Focus. The rigging system consists of a threaded axis with a cam lever.

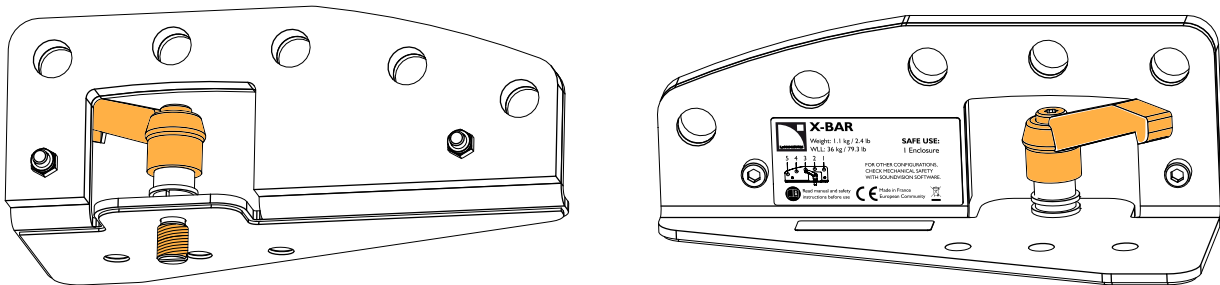

X-BAR is secured to the dedicated inserts on the enclosure, in front or rear extension position.

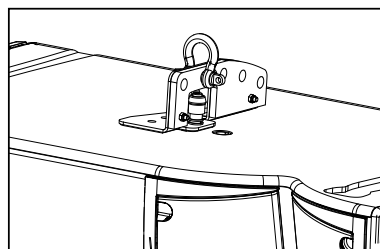
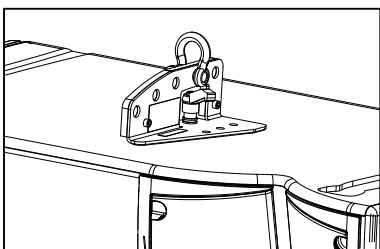
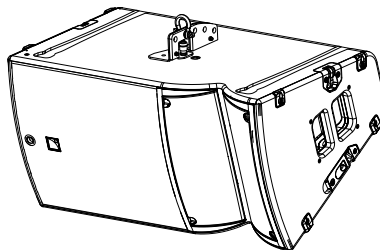
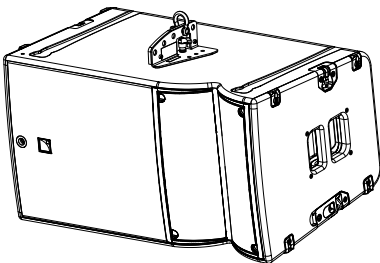

Five angulation holes are available.

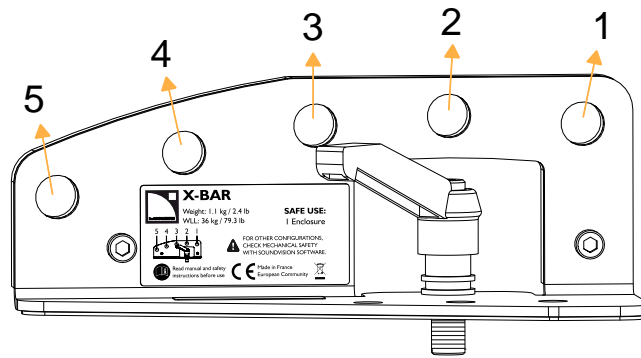

X-BAR is compatible with a Ø12 mm shackle WLL 1 t (provided) and with CLAMP250.

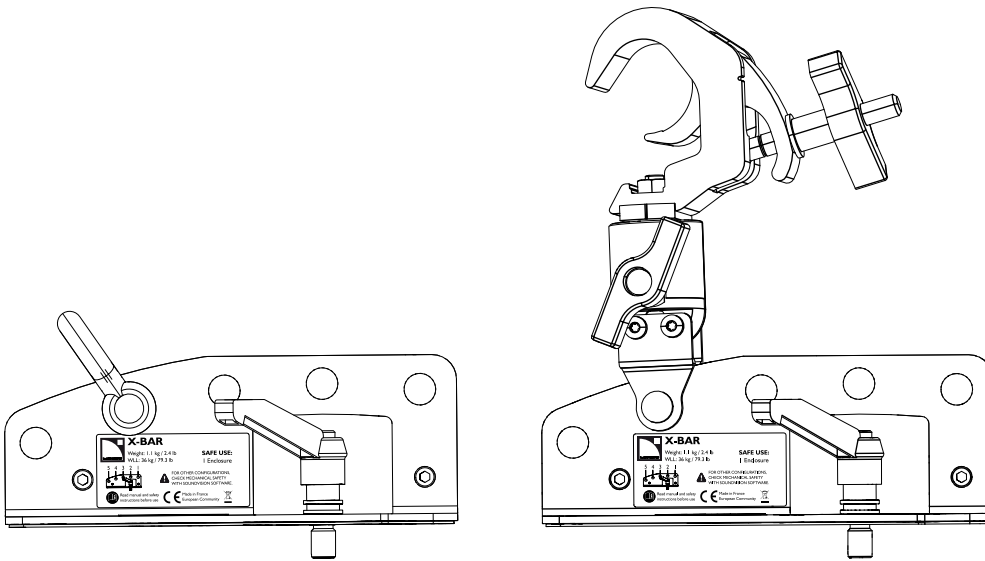

## Storage and handling elements

### KS21-CHARIOT

KS21-CHARIOT is a chariot designed to transport a stack of up to three KS21. It features two rigging arms to secure the lower KS21.

**⚠️ KS21-CHARIOT is intended for use only with L-Acoustics KS21.**

Use with other equipment may result in instability causing injury.

**⚠️ Risk of damage**

Do not secure A15 Wide/Focus directly on KS21-CHARIOT.

**⚠️** Do not move or transport more than three enclosures on KS21-CHARIOT.

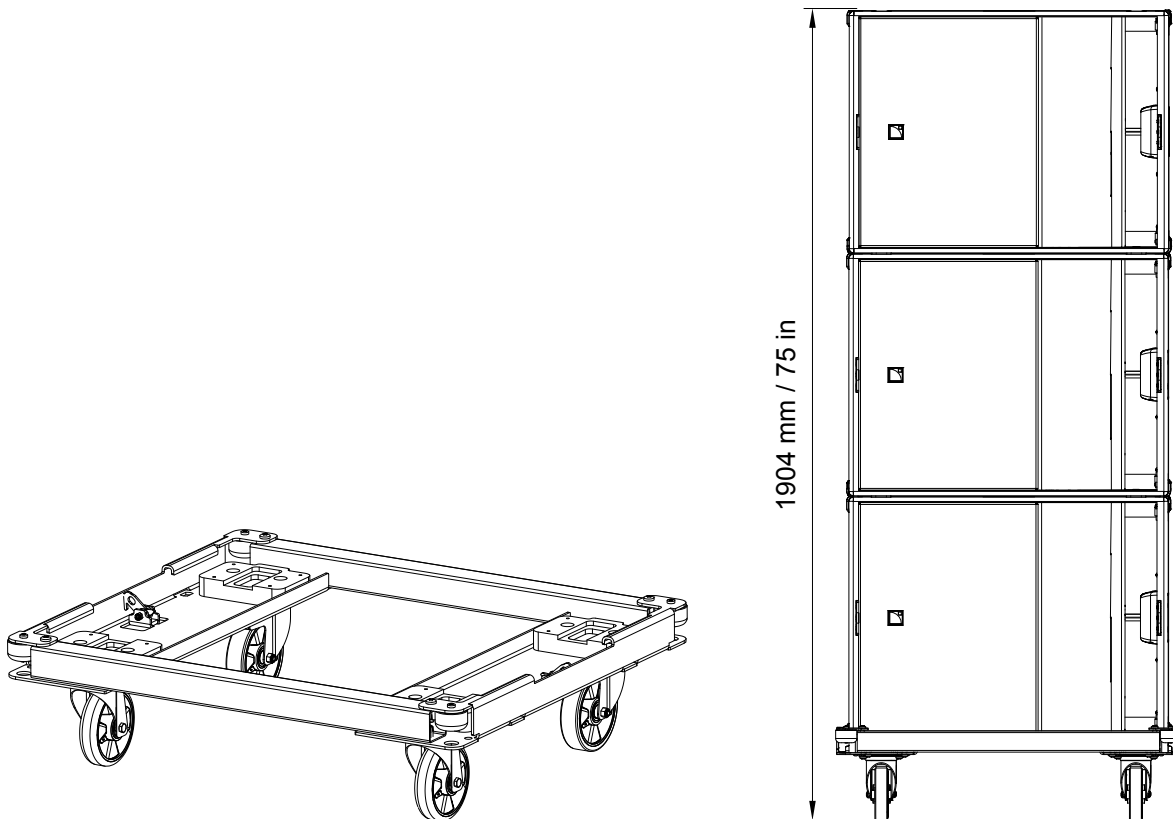

KS21-CHARIOT features two brakes for optimal stability.

**⚠️ Risk of brake damage**

Do not use the brakes during transportation.

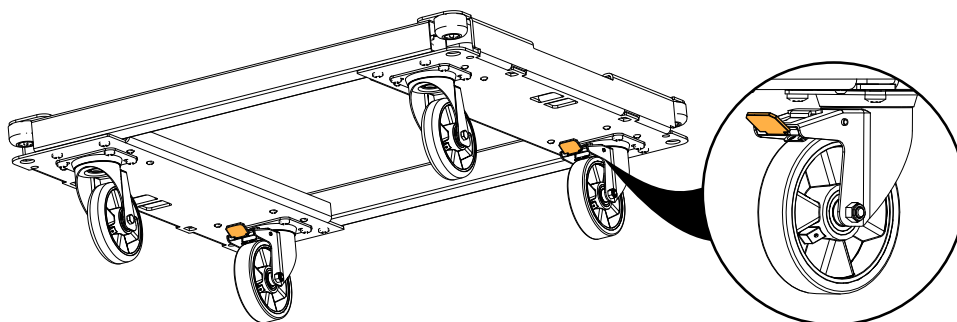



Multiple KS21-CHARIOT can be stacked for storage.

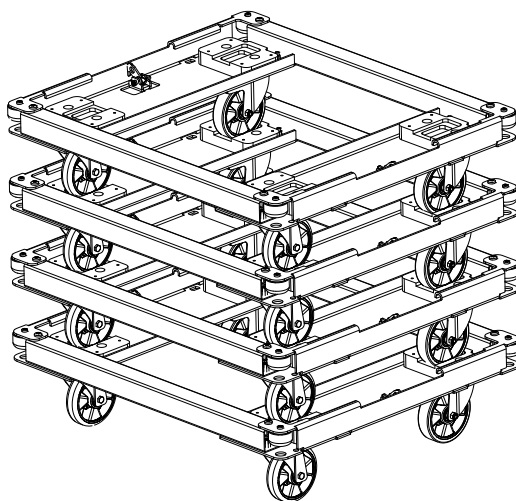

### KS21-PLA

KS21-PLA is a dolly board that can be secured to the front of a KS21 with two spring-loaded pins.

**!** **KS21-PLA is intended for use only with L-Acoustics KS21.**  
 Use with other equipment may result in instability causing injury.

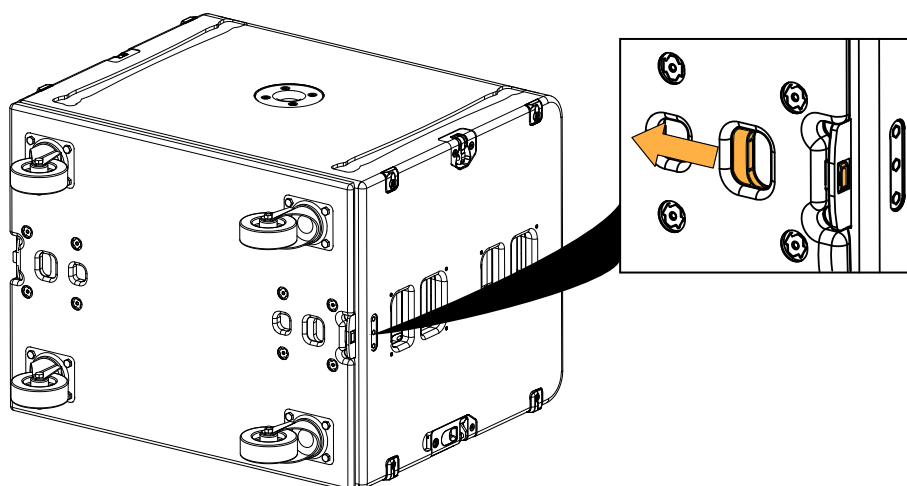

Multiple KS21-PLA can be stacked for storage.

**i** Turn the wheels outwards to stack KS21-PLA.

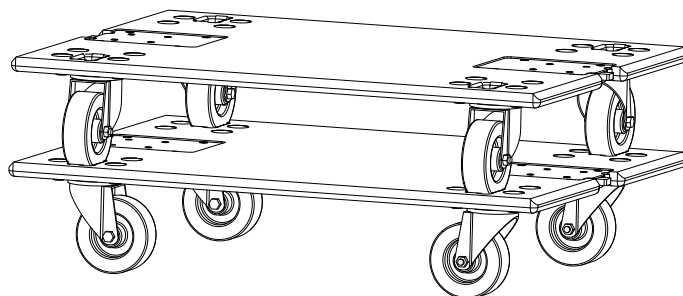

## KS21-COV and KS21-CHARIOTCOV

KS21-COV is an individual cover for KS21 on KS21-PLA. Two flaps provide access to the connector plate.

KS21-CHARIOTCOV is a cover for a stack of two to three KS21 on KS21-CHARIOT.

To fit a stack of two KS21, KS21-CHARIOTCOV must be folded inwards and secured with the integrated velcro straps.

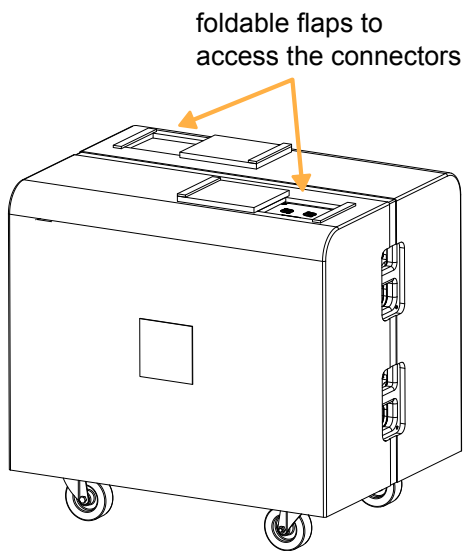

KS21-COV

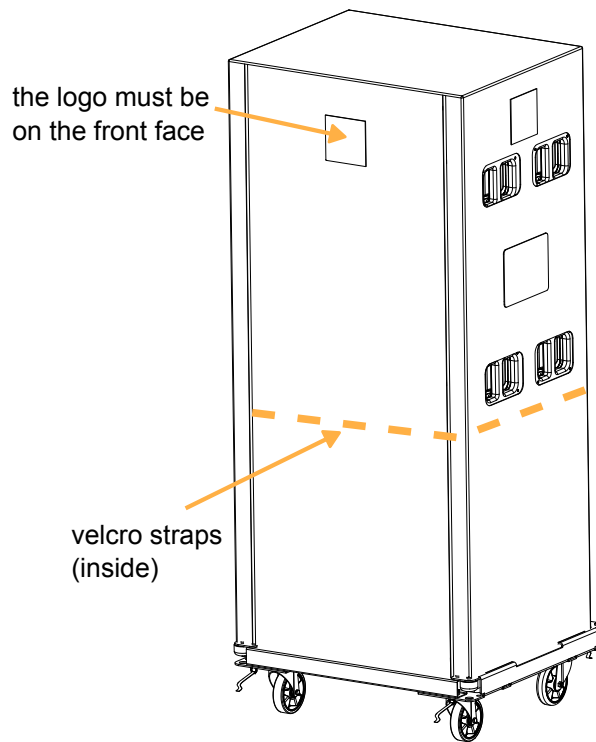

KS21-CHARIOTCOV

## Flight case for A15 Wide/Focus

L-Acoustics recommends the use of the A15 Wide/Focus flight case by Rythmes & Sons. They can be found on [www.rythmes.com](http://www.rythmes.com) under the reference FSE LA A15.G2.

The modular flight case can safely transport an array of two A15 Focus, or two A15 Wide, or one A15 Focus and one A15 Wide. The enclosures are positioned to be ready for use in a rigging procedure.

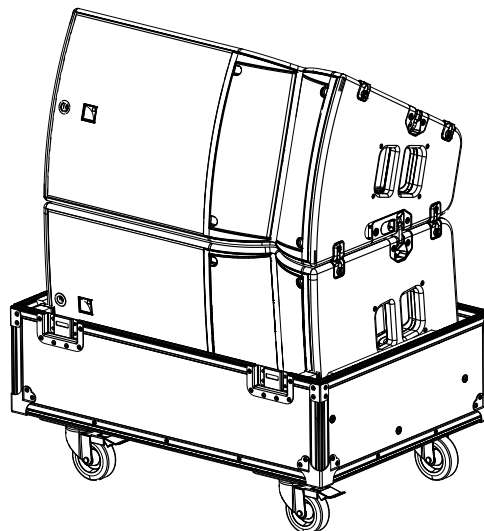
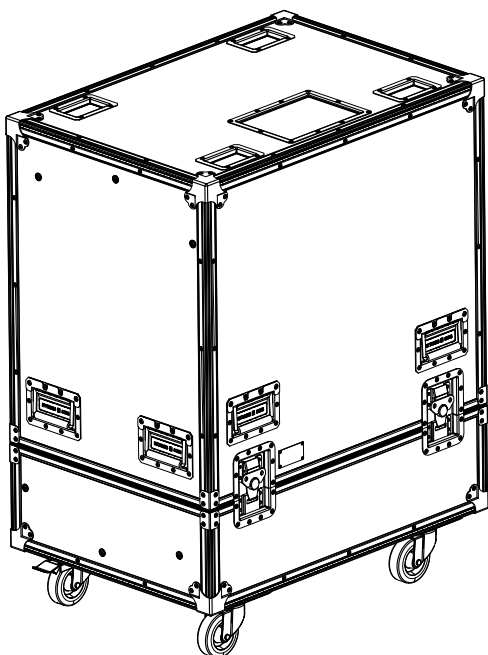

The support brackets inside the top and the bottom part of the flightcase can be secured in two distinct positions, to fit A15 Focus or A15 Wide.

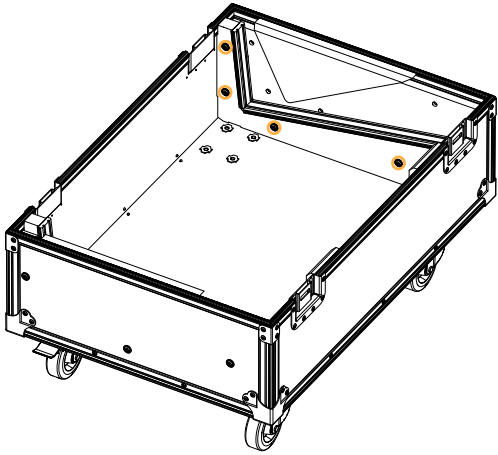

Position for A15 Focus

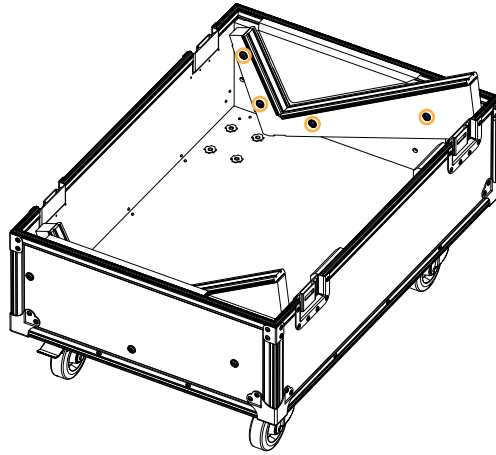

Position for A15 Wide

# Mechanical safety

## Flown configurations

The A15 rigging system complies with 2006/42/EC: Machinery Directive. It has been designed following the guidelines of BGV-C1.

2006/42/EC: Machinery Directive specifies a safety factor of 4 against the rupture. The flown deployments described in this manual achieve a safety factor of **4 or more**.

Refer to Soundvision for the safety factor of a specific deployment.

The **safe limit** gives the maximum number of elements for which the safety factor is compliant with the 2006/42/EC: Machinery Directive, within the use defined in this manual and regardless of the other deployment parameters (site angles, inter-element angles, etc.).

The **maximum limit** gives the maximum number of elements for which the safety factor can be compliant with the 2006/42/EC: Machinery Directive, when the other deployment parameters provide the best mechanical conditions.

For mixed arrays refer to your Soundvision model.

## A15 Wide/Focus

| configuration                | rigging accessory                        | safe limit                  | maximum limit     |
|------------------------------|--|-----------------------------|-------------------|
| Flown                        | X-BAR                                    | 1                           |                   |
| Vertical array               | A15-BUMP + M-BAR (optional)              | 8                           |                   |
|                              | A15-RIGBAR                               | 4                           |                   |
| Vertical array with pullback | A15-BUMP + M-BAR (optional) + A15-RIGBAR | A15 Wide: 5<br>A15 Focus: 8 | A15 Wide/Focus: 8 |
|                              | 2 × A15-RIGBAR                           | 4                           |                   |
| Radial array                 | 1 × A15-LIFT                             | 1 or 3                      |                   |
|                              | 2 × A15-LIFT                             | 2, 4, 5 or 6                |                   |
|                              | 3 × A15-LIFT                             | 7, 8 or 9                   |                   |

## KS21

| configuration  | rigging accessory | safe limit | maximum limit |
|----------------|-------------------|------------|---------------|
| Vertical array | A15-BUMP          | 8          | 16            |
|                | A15-RIGBAR        | 4          |               |

## A15 Wide/Focus + KS21

| configuration                | rigging accessory                        | safe / maximum limit |
|------------------------------|--|----------------------|
| Vertical array with pullback | A15-BUMP + M-BAR (optional) + A15-RIGBAR | 8                    |

## Other configurations

For other configurations, respect the recommended maximum limit for optimal stability.



### Use safety straps

Always use safety straps on stacked arrays where the enclosures are not connected by the rigging system.

Always use safety straps on stacked arrays higher than four enclosures.

## A15 Wide/Focus

| configuration          | rigging accessory    | maximum / safe limit |
|------------------------|----------------------|----------------------|
| Stacked vertical array | No rigging accessory | 1                    |
| Stacked vertical array | KS21-OUTRIG          | 4                    |
| Pole-mounted           | A-MOUNT              | 1                    |

## KS21

| configuration                       | rigging accessory      | maximum / safe limit   |
|-------------------------------------|------------------------|--|
| Stacked vertical array              | No rigging accessory   | 3  |
|                                     | KS21-OUTRIG            | 4  |
| Stacked upright                     | No rigging accessory   | 3  |
|                                     |                        |  |
| Stacked on chariot                  | KS21-CHARIOT           | 3  |
| Stacked on chariot with stabilizers | KS21-CHARIOT + K2-JACK | 4  |

## A15 Wide/Focus on KS21

| configuration                              | rigging accessory                                    | safe limit                         | maximum limit              |
|--|--|------------------------------------|----------------------------|
| Stacked on subwoofer with angle adjustment | A-TILT + KS21-OUTRIG<br>or KS21-CHARIOT with K2-JACK | 4 (including KS21)                 | 4 A15 Wide/Focus<br>4 KS21 |
| Stacked on subwoofer                       | KS21-OUTRIG<br>or KS21-CHARIOT with K2-JACK          | 3 A15 Focus / 2 A15 Wide<br>3 KS21 |                            |

## Assessing mechanical safety



### Mechanical safety of the rigging system

Before any installation, always model the system in Soundvision and check the **Mechanical Data** section for any stress warning or stability warning.

In order to assess the actual safety of any array configuration before implementation, refer to the following warnings:



### Rated working load limit (WLL) is not enough

The rated WLL is an indication of the element resistance to tensile stress. For complex mechanical systems such as loudspeaker arrays, WLLs cannot be used per se to determine the maximum number of enclosures within an array or to assess the safety of a specific array configuration.

### Maximum pullback angle

If a pullback accessory is available, the pullback angle must not exceed a 90° negative site angle.

### **Mechanical modeling with Soundvision**

The working load applied to each linking point, along with the corresponding safety factor, will depend on numerous variables linked to the composition of the array (type and number of enclosures, splay angles) and the implementation of the flying or stacking structure (number and location of flying points, site angle). This cannot be determined without the complex mechanical modeling and calculation offered by Soundvision.

### **Assessing the safety with Soundvision**

The overall safety factor of a specific mechanical configuration always corresponds to the lowest safety factor among all the linking points. Always model the system configuration with the Soundvision software and check the **Mechanical Data** section to identify the weakest link and its corresponding working load. By default, a stress warning will appear when the mechanical safety goes beyond the recommended safety level.

### **Safety of ground-stacked arrays in Soundvision**

For ground-stacked arrays, a distinct stability warning is implemented in Soundvision. It indicates a tipping hazard when the array is not secured to the ground, stage or platform. It is the user's responsibility to secure the array and to ignore the warning.

### **Additional safety for flown arrays**

When flying an array, use available holes to implement a secondary safety.

### **Considerations must be given to unusual conditions**

Soundvision calculations are based on usual environmental conditions. A higher safety factor is recommended with factors such as extreme high or low temperatures, strong wind, prolonged exposition to salt water, etc. Always consult a rigging specialist to adopt safety practices adapted to such a situation.

# Loudspeaker configurations

## A15 Wide/Focus line source

---

In this configuration the system operates over the nominal bandwidth of the enclosures.

The [A15] preset delivers a reference frequency response in medium throw applications.

The A15 Wide/Focus enclosures are driven by the LA4X / LA8 / LA12X amplified controllers.

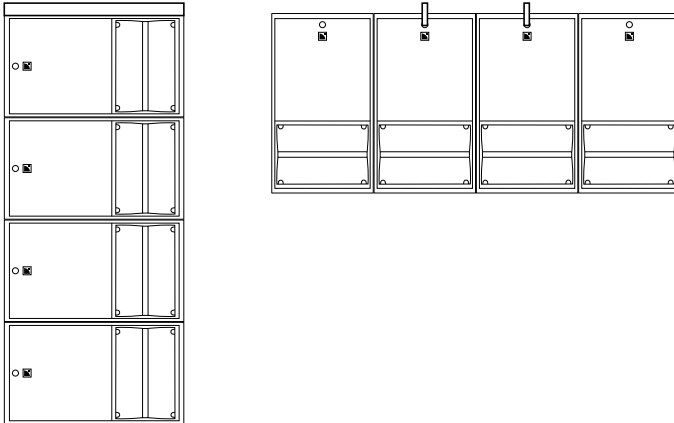

### Preset

### Frequency range (-10 dB)

[A15]

41 Hz - 20 kHz (A15 Focus)

42 Hz - 20 kHz (A15 Wide)

## A15 Wide/Focus line source with low-frequency element

In this configuration, the bandwidth of the A15 system is extended down to 29 Hz and the LF contour is reinforced. The [KS21\_60] preset provides KS21 with an upper frequency limit at 60 Hz.

The A15 Focus, A15 Wide and KS21 enclosures are driven by the LA4X / LA8 / LA12X amplified controllers.

### 3 A15 Wide/Focus : 2 KS21

reinforced contour

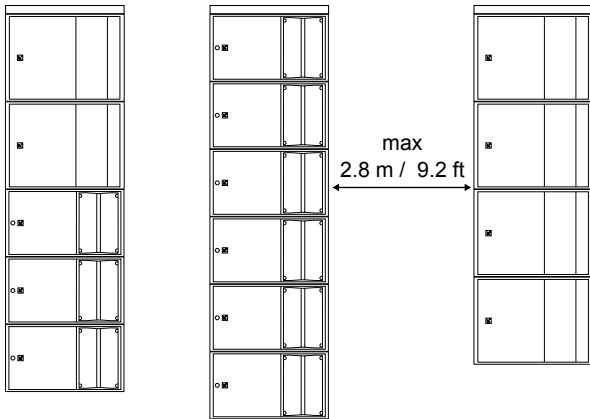

### 1 A15 Wide/Focus : 1 KS21

reinforced contour

+ 3 dB at 55 Hz

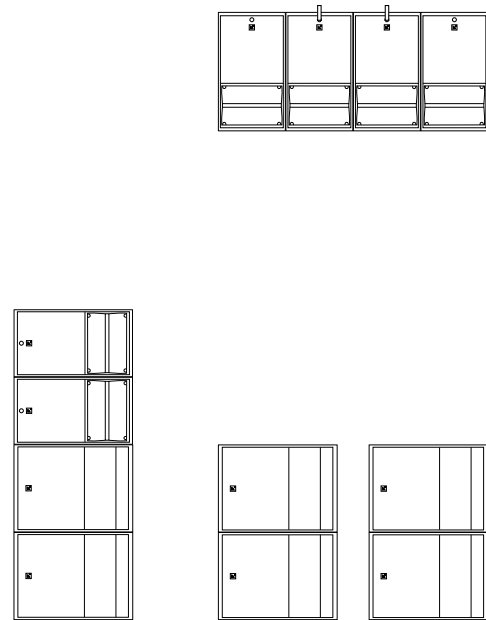

|                                 |                           |           |
|---------------------------------|---------------------------|-----------|
| <b>Enclosure</b>                | A15 Wide/Focus            | KS21      |
| <b>Preset</b>                   | [A15]                     | [KS21_60] |
| <b>Recommended ratio</b>        | 1 A15 Wide/Focus : 1 KS21 |           |
| <b>Frequency range (-10 dB)</b> | 29 Hz - 20 kHz            |           |

#### ! Use [xxxx\_xx\_C] or [xxxx\_xx\_Cx] on a reversed subwoofer in a cardioid configuration

The cardioid configuration consists in reversing 1 element in an array of 4 subwoofers. Refer to the subwoofer owner's manual and to the **Cardioid configurations** technical bulletin.

#### ! Grouping subwoofers

Place the subwoofer enclosures side by side. If not possible, the maximum distance between two adjacent acoustic centers must be 2.8 m (9.2 ft) or 1.7 m (5.6 ft) if the upper frequency limit of the subwoofer system is at 60 Hz or 100 Hz, respectively.

#### ! Delay values

Do not forget to add the pre-alignment and geometric delays depending on the configuration.

### Pre-alignment delays

| presets                                   | pre-alignment delay values and polarity settings  |   |
|---|---|---|
| [A15] or [A15_FI] or [A15_MO] + [KS21_60] | A15 Wide/Focus = 0 ms <input style="background-color: #cccccc;" type="button" value="+"/> | KS21 = 2.3 ms <input style="background-color: #cccccc;" type="button" value="+"/> |
| [A15] or [A15_FI] + [KS21_60_C]           | A15 Wide/Focus = 9 ms <input style="background-color: #cccccc;" type="button" value="+"/> | KS21 = 0 ms <input style="background-color: #ff0000;" type="button" value="-"/>   |



| presets                          | pre-alignment delay values and polarity settings                                    |  |
|----------------------------------|---|--|
| [A15] or [A15_FI] + [KS21_60_Cx] | A15 Wide/Focus = 8 ms <input data-bbox="967 174 1018 228" type="button" value="+"/> | KS21 = 0 ms <input data-bbox="1441 174 1492 228" type="button" value="+"/> |

## A15 Wide/Focus line source element

A single A15 Wide/Focus can be used as a line source element. In this configuration, the system operates over the nominal bandwidth of the enclosure.

The [A15\_FI] preset delivers a reference frequency response in short throw applications.

The A15 Wide/Focus enclosure are driven by the LA4X / LA8 / LA12X amplified controllers.

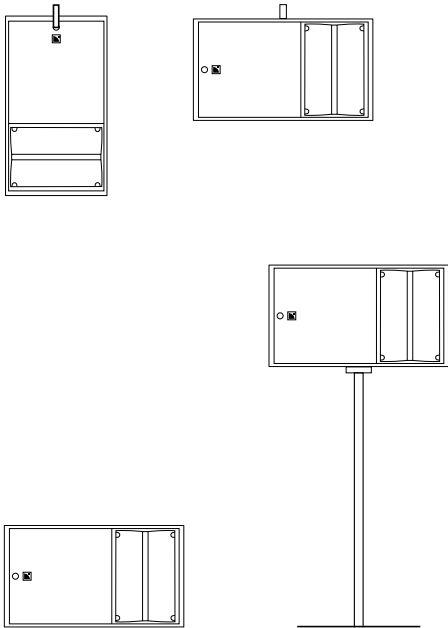

**Preset**

[A15\_FI]

**Frequency range (-10 dB)**

42 Hz - 20 kHz (A15 Focus)

43 Hz - 20 kHz (A15 Wide)

## A15 Wide/Focus line source element with low-frequency element

With a complementary subwoofer, the system is extended in the low end and the LF contour is reinforced.

The [A15\_FI] preset delivers a reference frequency response in short throw applications. The [KS21\_60] preset provides KS21 with an upper frequency limit at 60 Hz.

The A15 Wide/Focus and KS21 enclosures are driven by the LA4X / LA8 / LA12X amplified controllers.

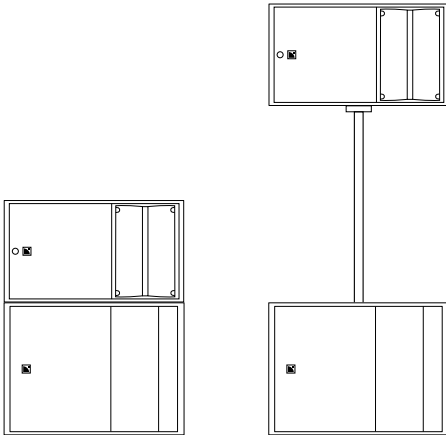

|                                 |                           |           |
|---------------------------------|---------------------------|-----------|
| <b>Enclosure</b>                | A15 Wide/Focus            | KS21      |
| <b>Preset</b>                   | [A15_FI]                  | [KS21_60] |
| <b>Recommended ratio</b>        | 1 A15 Wide/Focus : 1 KS21 |           |
| <b>Frequency range (-10 dB)</b> | 29 Hz - 20 kHz            |           |

### ! Use [xxxx\_xx\_C] or [xxxx\_xx\_Cx] on a reversed subwoofer in a cardioid configuration

The cardioid configuration consists in reversing 1 element in an array of 4 subwoofers.

Refer to the subwoofer owner's manual and to the **Cardioid configurations** technical bulletin.

### ! Grouping subwoofers

Place the subwoofer enclosures side by side. If not possible, the maximum distance between two adjacent acoustic centers must be 2.8 m (9.2 ft) or 1.7 m (5.6 ft) if the upper frequency limit of the subwoofer system is at 60 Hz or 100 Hz, respectively.

### ! Delay values

Do not forget to add the pre-alignment and geometric delays depending on the configuration.

### Pre-alignment delays

| presets                                   | pre-alignment delay values and polarity settings  |   |
|---|---|---|
| [A15] or [A15_FI] or [A15_MO] + [KS21_60] | A15 Wide/Focus = 0 ms <input style="background-color: #cccccc;" type="button" value="+"/> | KS21 = 2.3 ms <input style="background-color: #cccccc;" type="button" value="+"/> |
| [A15] or [A15_FI] + [KS21_60_C]           | A15 Wide/Focus = 9 ms <input style="background-color: #cccccc;" type="button" value="+"/> | KS21 = 0 ms <input style="background-color: #ff0000;" type="button" value="-"/>   |
| [A15] or [A15_FI] + [KS21_60_Cx]          | A15 Wide/Focus = 8 ms <input style="background-color: #cccccc;" type="button" value="+"/> | KS21 = 0 ms <input style="background-color: #cccccc;" type="button" value="+"/>   |

## A15 Wide/Focus stage monitor

A single A15 Wide/Focus can be used as a stage monitor. In this configuration, the system operates over the nominal bandwidth of the enclosure.

The [A15\_MO] preset delivers a reference frequency response in stage monitoring applications.

The A15 Wide/Focus enclosure are driven by the LA4X / LA8 / LA12X amplified controllers.

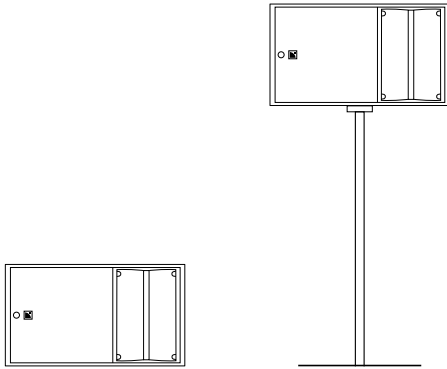

### Preset

[A15\_MO]

### Frequency range (-10 dB)

42 Hz - 20 kHz (A15 Focus)

43 Hz - 20 kHz (A15 Wide)

## Low-latency preset

A low-latency preset is available for the A15 enclosure used as a monitor ([A15\_MO]). It reduces latency from 3.84 ms down to 1.18 ms (LA8) and 0.84 ms (LA2Xi / LA4X / LA12X). If the monitor is combined with a subwoofer, a custom preset must be used.

## A15 Wide/Focus stage monitor with low-frequency element

With a complementary subwoofer, the system is extended in the low end and the LF contour is reinforced.

The [A15\_MO] preset delivers a reference frequency response in stage monitoring applications. The [KS21\_60] preset provides KS21 with an upper frequency limit at 60 Hz.

The A15 Wide/Focus and KS21 enclosures are driven by the LA4X / LA8 / LA12X amplified controllers.

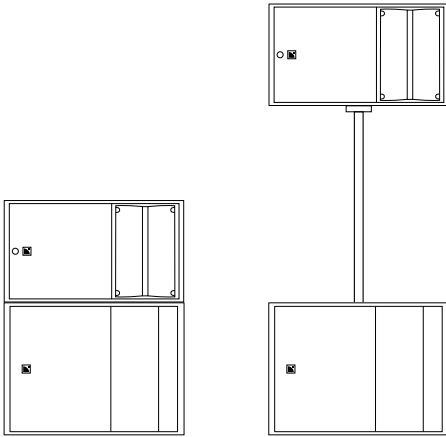

### Enclosure

A15 Wide/Focus

KS21

### Preset

[A15\_MO]

[KS21\_60]

### Recommended ratio

1 A15 Wide/Focus : 1 KS21

### Frequency range (-10 dB)

29 Hz - 20 kHz

### ! Delay values

Do not forget to add the pre-alignment and geometric delays depending on the configuration.

### Pre-alignment delays

| presets                                   | pre-alignment delay values and polarity settings |  |
|---|--|--|
| [A15] or [A15_FI] or [A15_MO] + [KS21_60] | A15 Wide/Focus = 0 ms <input type="checkbox"/>   | KS21 = 2.3 ms <input type="checkbox"/> |

! [xx\_MO] presets for the A series use the amplified controller low latency operating mode. When used along with subwoofers, it is recommended to use the subwoofers in low latency operating mode. To achieve this, create custom presets combining low latency channel sets and subwoofer channel sets.

If the subwoofers are driven from a dedicated amplified controller using a subwoofer factory preset, they are operated in normal latency mode. Therefore, an additional delay should be set to the [xx\_MO] low latency channels to align them: 2.66 ms on LA4 and LA8 or 3.00 ms on LA4X and LA12X.

# Inspection and preventive maintenance

## How to do preventive maintenance

---

Inspect the system before any deployment and after any corrective maintenance operation.

Perform preventive maintenance at least once a year.

### Rigging and hardware

Perform the [Rigging part inspection](#) (p.55) on each rigging part.

Use the [Mechanical system overview](#) (p.56) to identify critical parts of the system and apply the specific checks described in the [Inspection references](#) (p.63).

Do the [Rigging check](#) (p.69).

If any parts are damaged, contact your L-Acoustics representative for further instructions.

### Acoustics

Perform the [Enclosure check](#) (p.71).

Perform the [Listening test](#) (p.73) to detect any degradation in sound quality.

If necessary, refer to the [Corrective maintenance](#) (p.107) section for speaker repair kits and maintenance instructions.

## Rigging part inspection

---

### About this task

For critical rigging parts, use the [Inspection references](#) (p.63) for comparison and specific manipulations.

The term "rigging part" comprises:

- lifting accessories such as clamps and shackles
- rigging accessories such as rigging frames, rigging interfaces, and brackets
- fasteners used for assembling two products together such as ball-locking pins, rigging axes, and safety pins
- rigging elements integrated in the product such as rigging arms and rails
- transportation accessories

This inspection procedure covers only L-Acoustics products. To inspect other products that are part of the lifting chain, refer to the manufacturer's instructions.

### Prerequisite

Perform the inspection in a well-lit environment.

### Procedure

1. Check that the rigging part is present.
2. If applicable, disassemble the rigging part from the enclosure or the rigging accessory.

Check that the tethers are intact and safely secured.

3. Inspect the part from every side.

Compare with the **reference pictures**.

Check for:

- corrosion
- wear and cracks
- bends and dents
- holes
- missing safety cues
- missing identification labels

- missing or loose fasteners



### Replacing screws

If a screw is loose, remove and replace it.

Always use the new screws provided in the repair kit.

If no new screw is available, add blue threadlocker before reusing the screw.

Do not apply more than the indicated torque.

4. Check the **geometry** of the part to identify critical deformations.

Place the rigging part on a flat surface or hold a level against it.

5. Check the **moving parts**.

Make sure that the mechanism engages correctly.



### What to do next

If a problem is detected, perform the authorized maintenance operations or contact your L-Acoustics representative.

## Mechanical system overview

---

Critical parts of the lifting chains are highlighted.

The  indicates a visual inspection. The  indicates a functional check.



Perform the [Rigging part inspection](#) (p.55) on critical parts.

For each part, refer to the [Inspection references](#) (p.63).



### Replacing screws

If a screw is loose, remove and replace it.

Always use the new screws provided in the repair kit.

If no new screw is available, add blue threadlocker before reusing the screw.

Do not apply more than the indicated torque.

# A15 Wide/Focus and KS21 array with A15-BUMP and M-BAR

Shackles (p.63) 

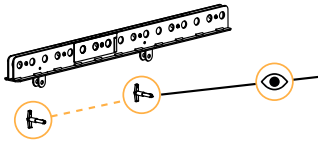
 Ball-locking pins (p.64)

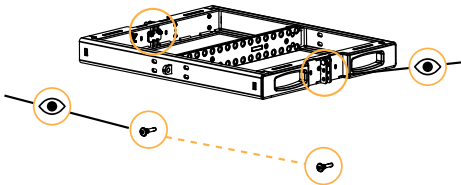
Ball-locking pins (p.64)  the yellow label is present  
the rigging arm can rotate freely

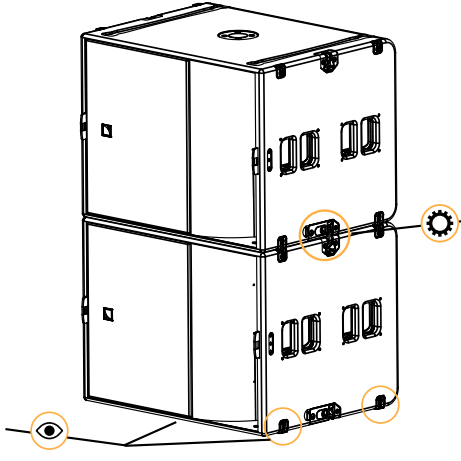
 Rigging check (p.69)  
Runners and corner stops (p.66)

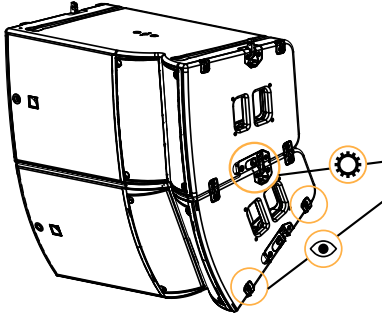
 Rigging check (p.69)  
Runners and corner stops (p.66)

## A15 Wide/Focus array with A15-LIFT

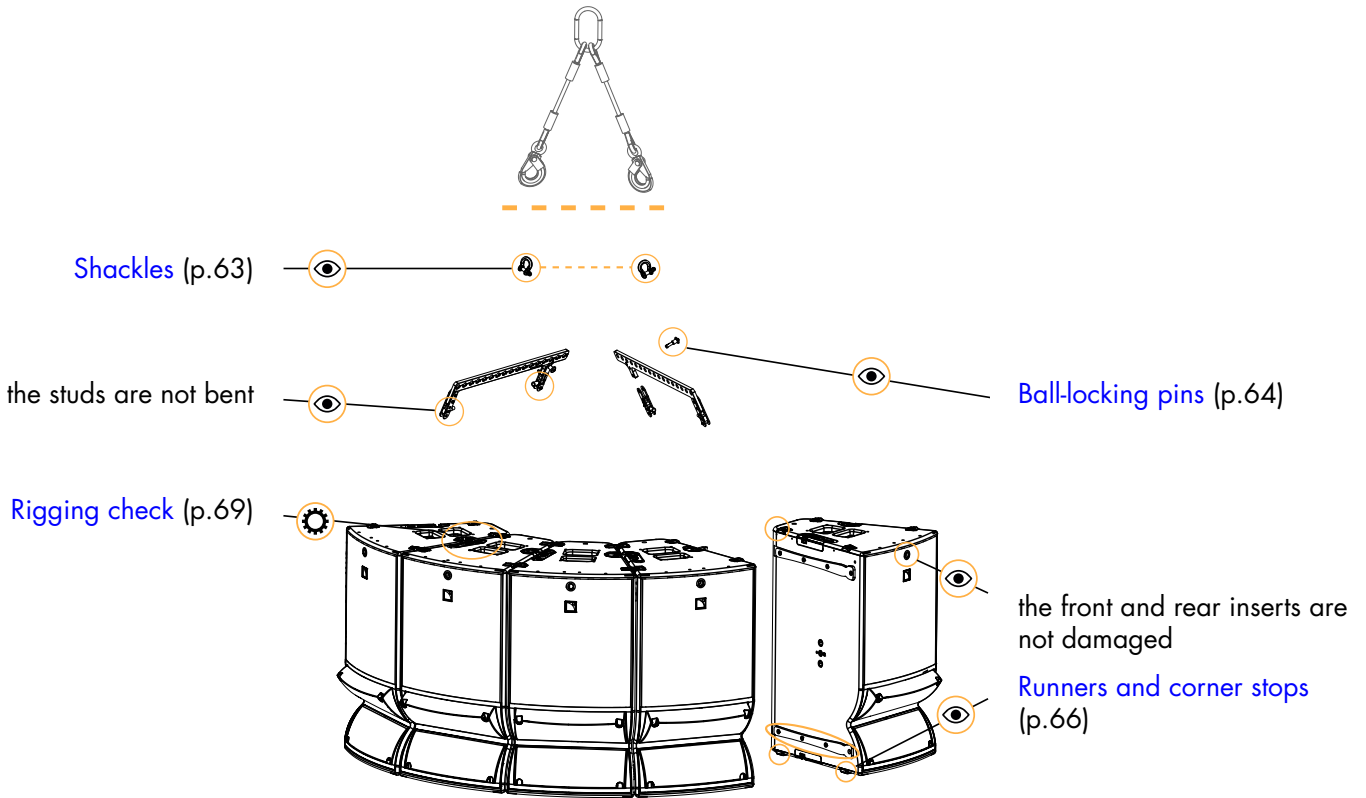

## A15 Wide/Focus with X-BAR and CLAMP250

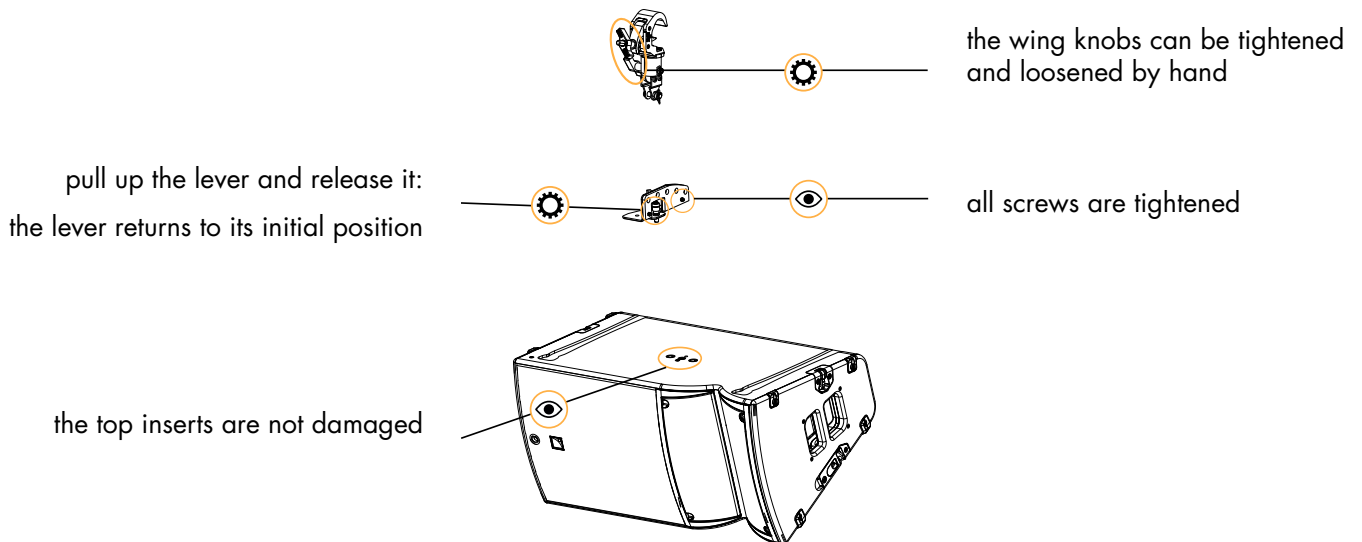



# KS21 array with A15-RIGBAR



Shackles (p.63)

Ball-locking pins (p.64)

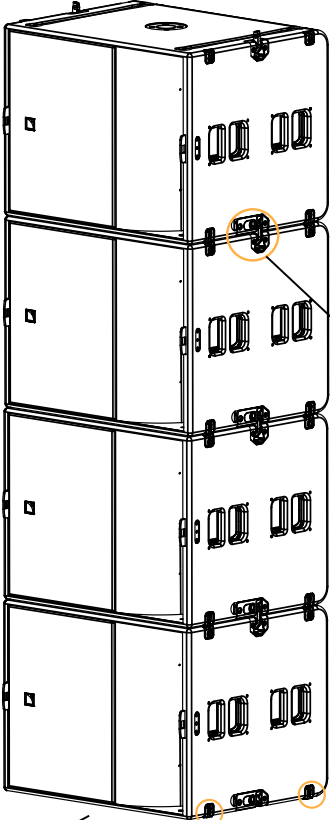
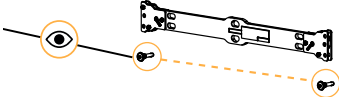

Rigging check (p.69)

Runners and corner stops (p.66)

## A15 Wide/Focus and A-MOUNT pole-mounted on KS21

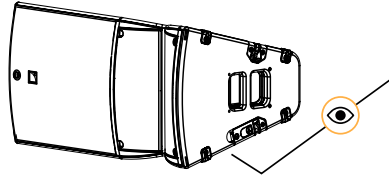

the bottom inserts are not damaged

all screws are tightened  
the angle axis is not bent

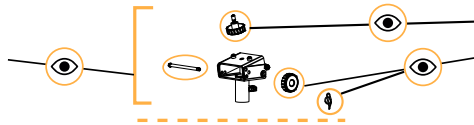
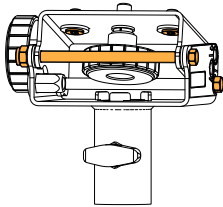
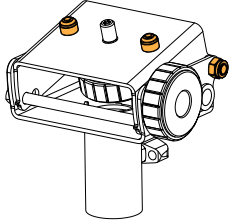

**Threaded knobs** (p.68)

make sure that either the locking cotter pin or the knob is present



Make sure the pole is compatible with the KS21 pole socket. Refer to **KS21** (p.25) for more information.

**Pole-mount socket** (p.67)

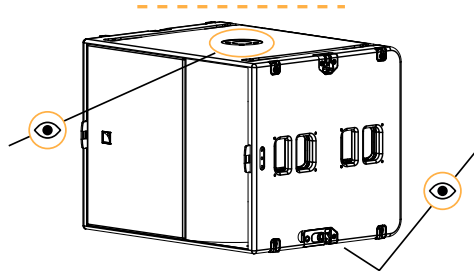

**Runners and corner stops** (p.66)

# A15 Wide/Focus stacked on A-TILT and KS21 with KS21-OUTRIG

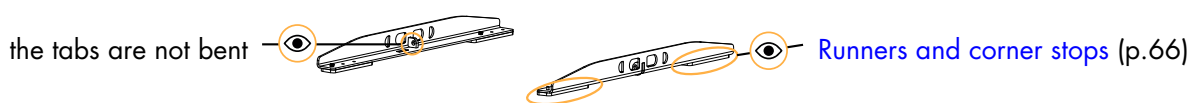
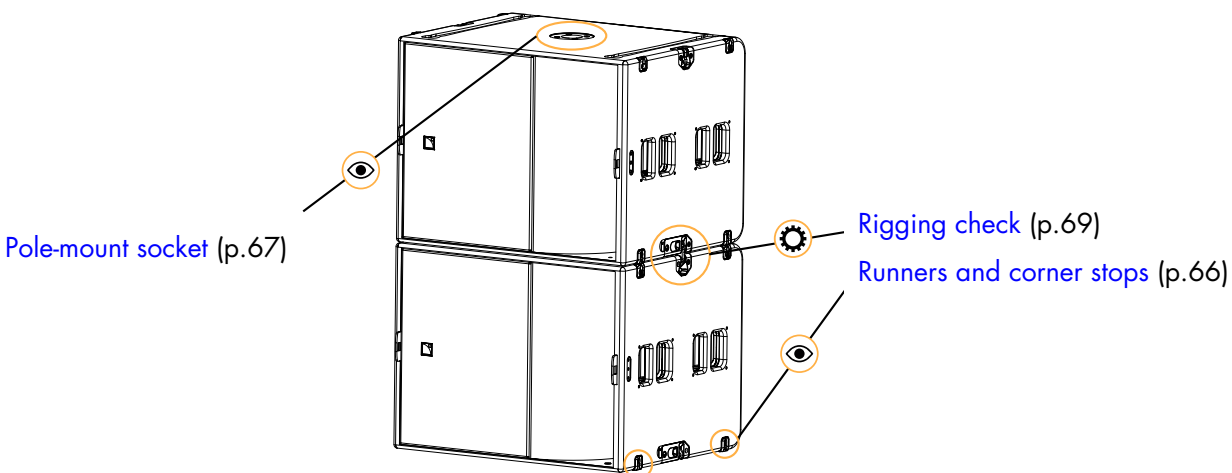
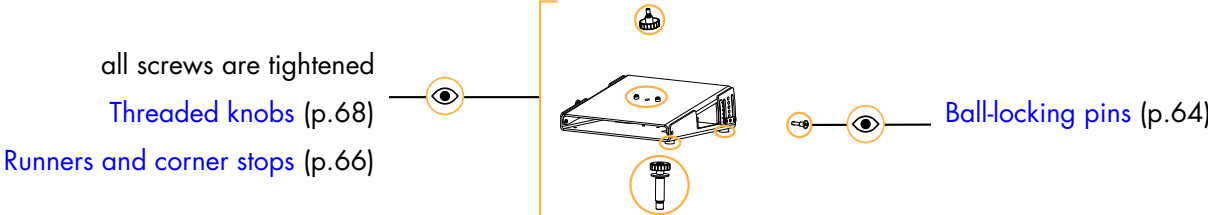
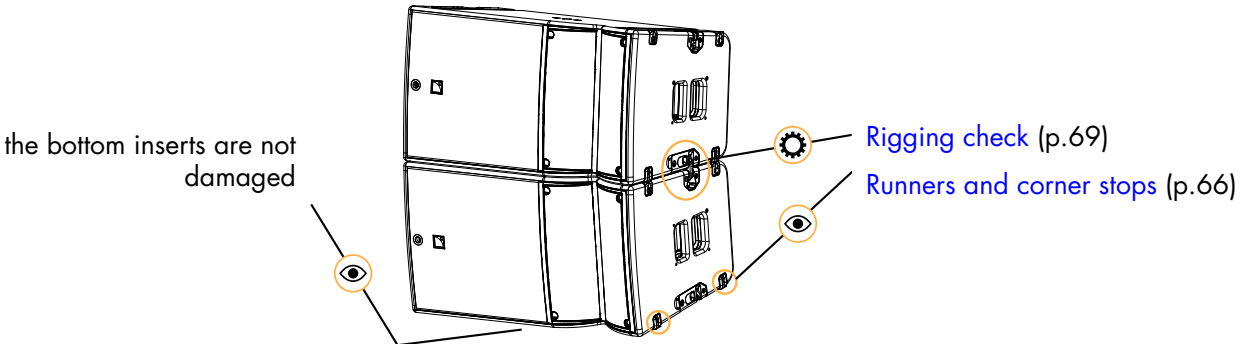

## A15 Wide/Focus stacked on KS21 with K2-CHARIOT and K2-JACK

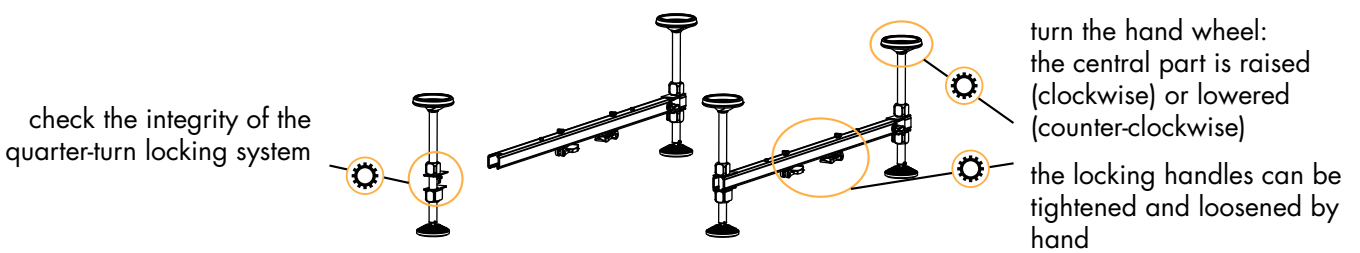
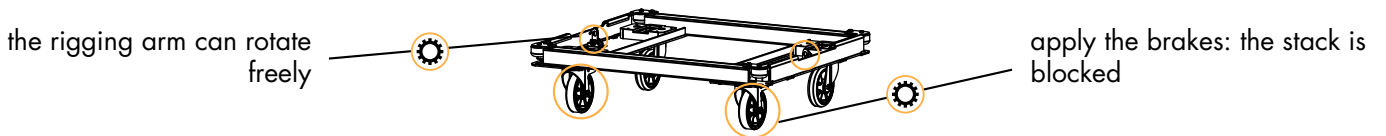
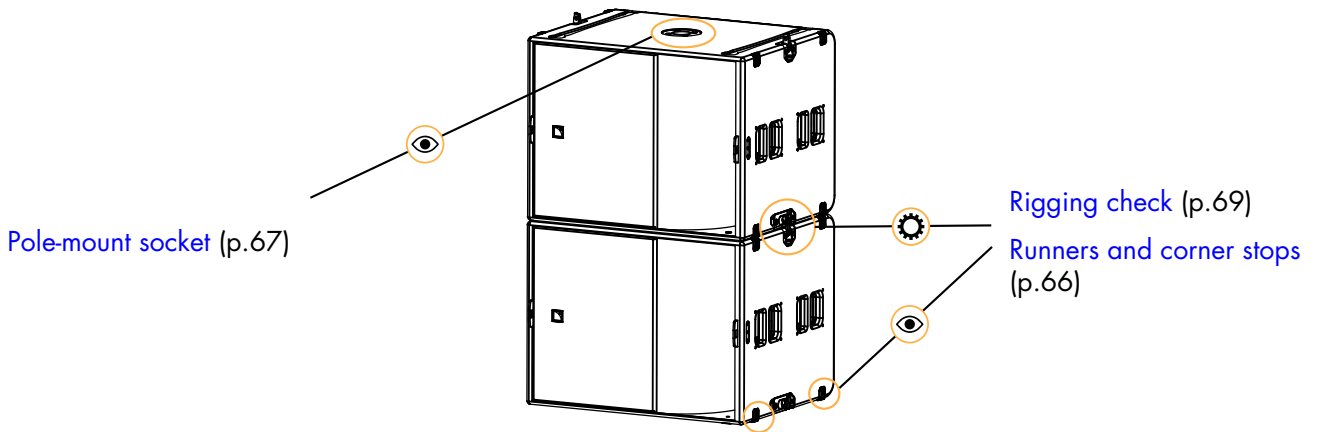
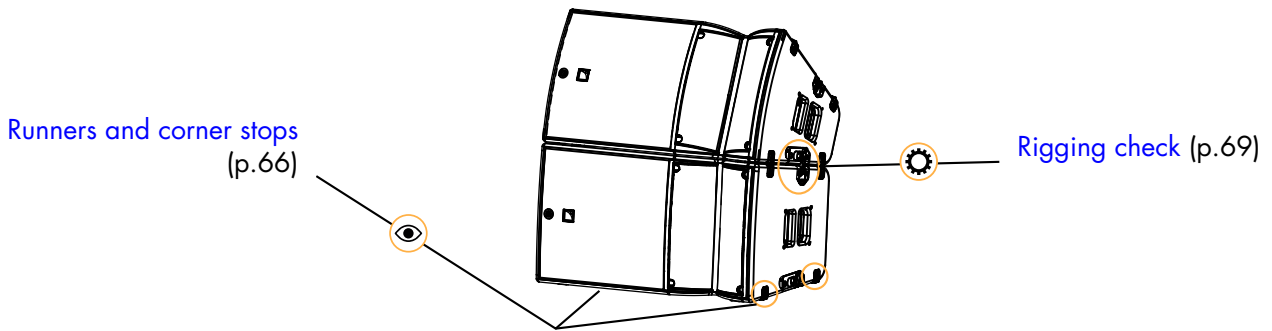

## Inspection references

---

### Shackles

Drive the shackle axis in its lodging. Make sure that the end is flush with the shackle.

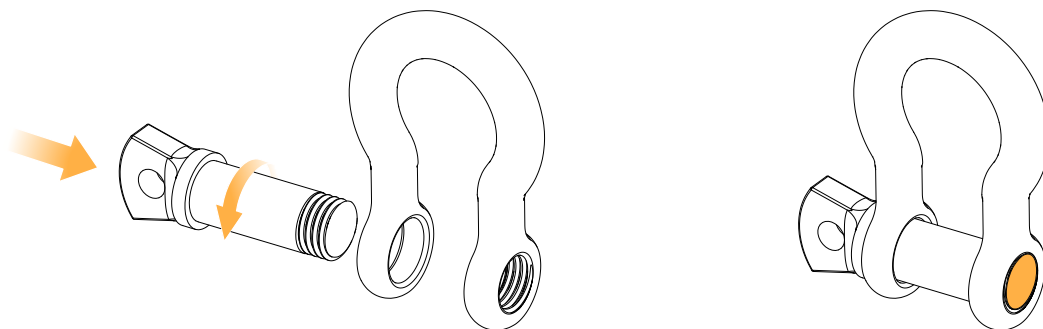

### Related tasks

[Rigging part inspection \(p.55\)](#)

## Ball-locking pins

- Tethers are intact and safely secured.
- Test the ball-locking mechanism (see [Moving parts](#) (p.65)).

### Reference pictures

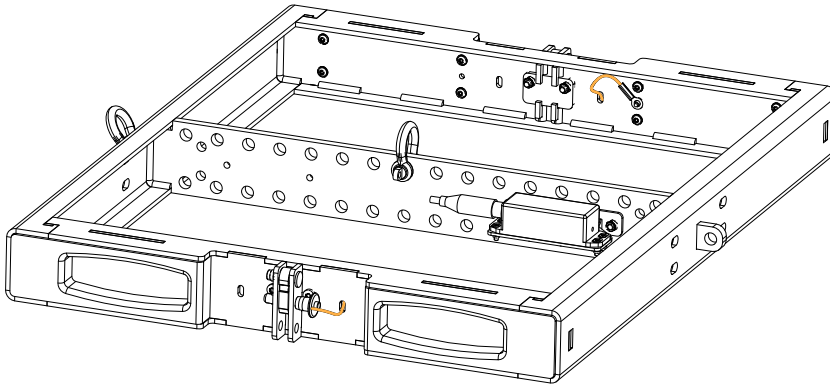

A15-BUMP

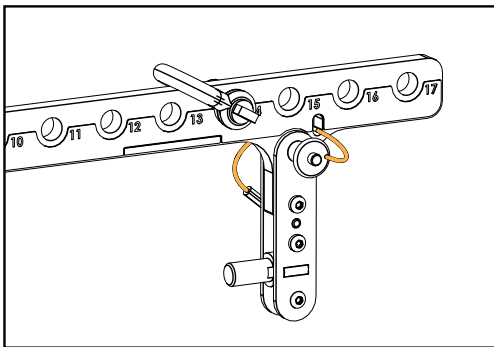

A15-LIFT

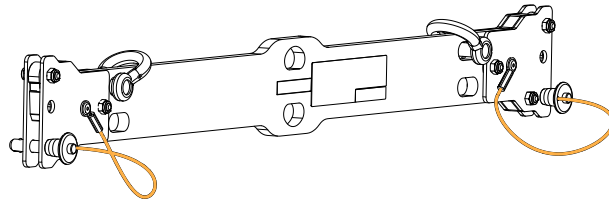

A15-RIGBAR

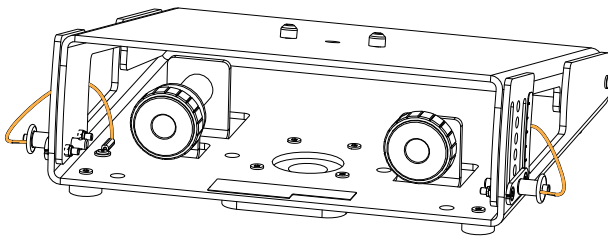

A-TILT

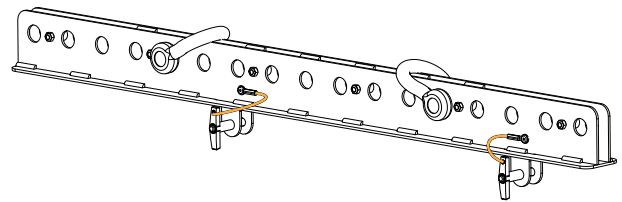

M-BAR

## Moving parts

1. Press the push button. The ball-locking mechanism is retracted.
2. Release the button. The ball-locking mechanism is activated.

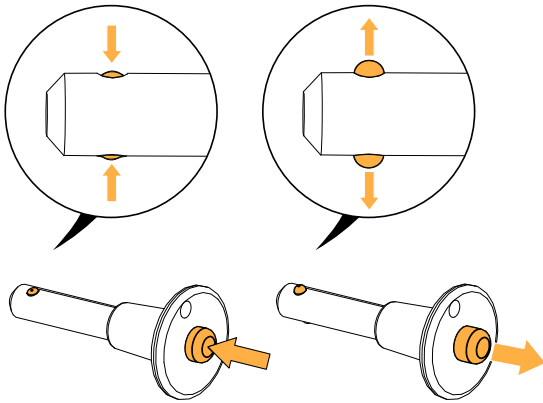

3. Insert the pin in each storage and rigging hole. Pull and rotate the pin. The pin must remain inside the hole.

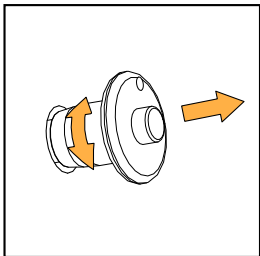

If the pin is inserted in two plates, the ball must pass through both plates and lock the pin in place.

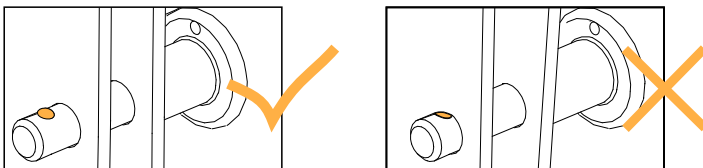

If the check fails, **immediately withdraw the product from use and contact L-Acoustics.**

## Related tasks

[Rigging part inspection](#) (p.55)

## Runners and corner stops

- Runners are not worn out.
- Screws are tightened.

### Reference pictures

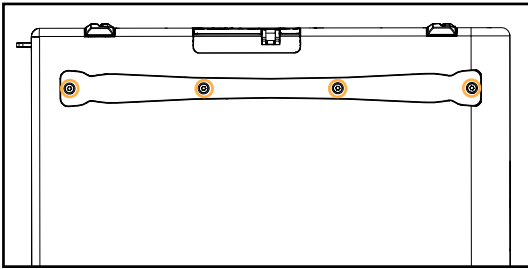

KS21 ground runner

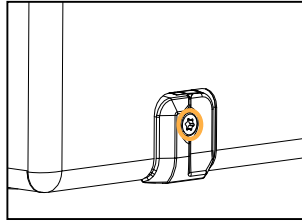

KS21 corner stop

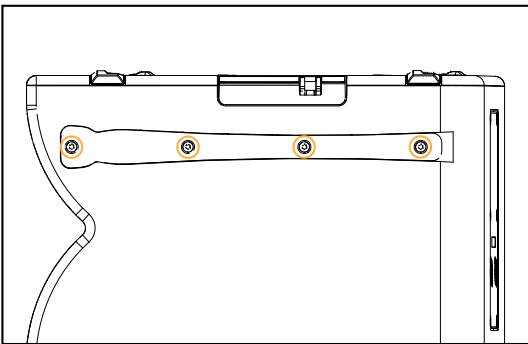

A15 Wide/Focus ground runner

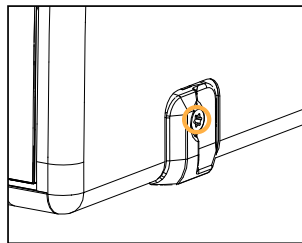

A15 Wide/Focus corner stop

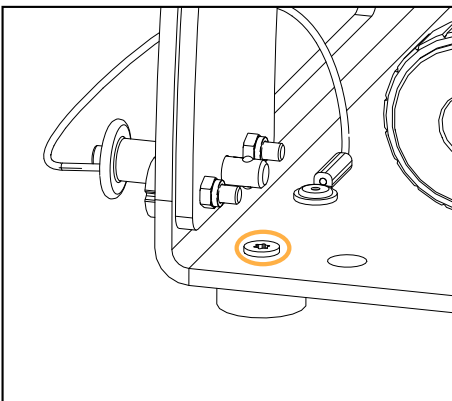

A-TILT runner

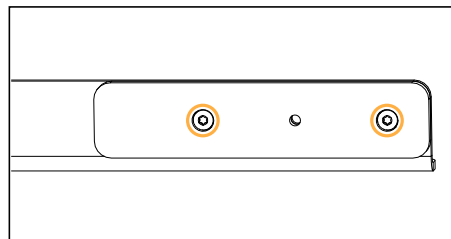

KS21-OUTRIG runner

**!** Contact your L-Acoustics representative for repair instructions.

### Related tasks

[Rigging part inspection \(p.55\)](#)



## Pole-mount socket

- Pole-mount socket is not damaged or bent.
- Screws are tightened.
- Socket plug is present.

### Reference pictures

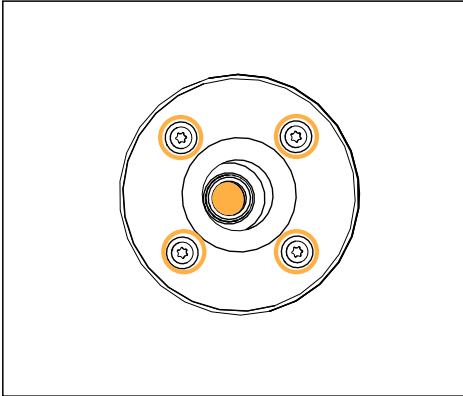

KS21 pole-mount socket



**Contact your L-Acoustics representative for repair instructions.**

### Related tasks

[Rigging part inspection \(p.55\)](#)

## Threaded knobs

- Head part does not have cracks.
- Head part is tightly secured to the body part.
- All washers are present.

### Reference pictures

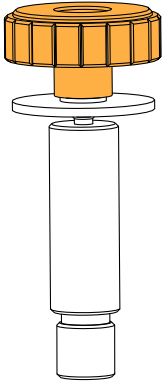

A-TILT  
subwoofer knob

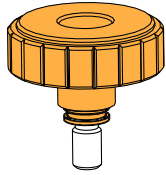

A-TILT and  
A-MOUNT  
enclosure knob

### Related tasks

[Rigging part inspection](#) (p.55)

## Rigging check

### About this task

**!** The procedure is described with two A15 Wide/Focus but can be executed identically with two KS21.

### Procedure

1. Secure one A15 Wide/Focus on top of another one.

**i** Push and slide to unlock the spring-loaded pin.

Connect the rigging systems on both sides.

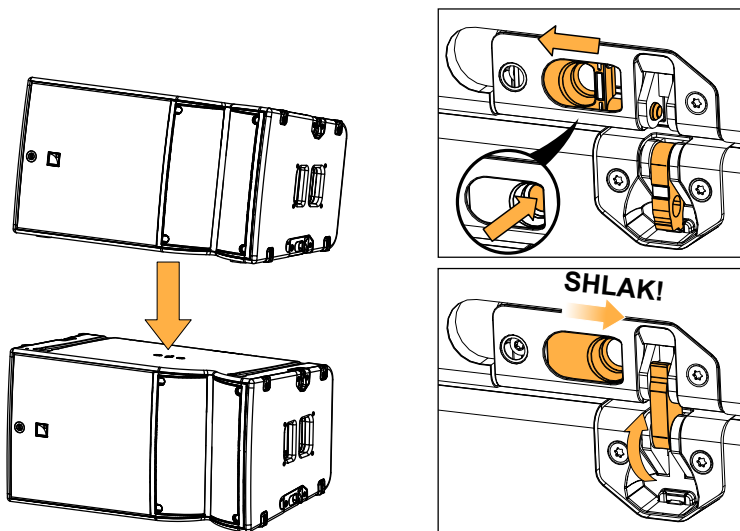

- The rigging arm is removed from its storage position with some resistance.
- When pushing and sliding the mechanism, the spring-loaded pin is retracted with some resistance.
- Upon release, the spring-loaded pin quickly returns to its initial position.
- The yellow labels on the rigging arm and on the spring-loaded pin are visible when the rigging system is not locked.

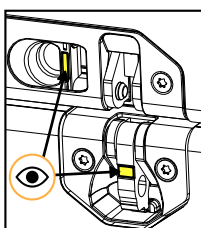

not locked

- No yellow labels are visible when the rigging system is locked.

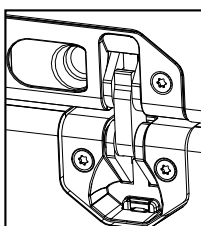

locked

2. Hold the top enclosure by the handles and shake the assembly.  
The two enclosures remain attached.

3. Unlock the rigging system on both sides.

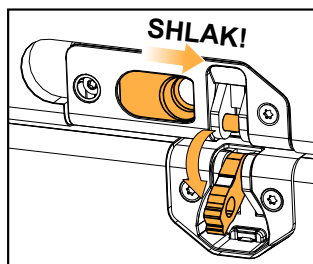
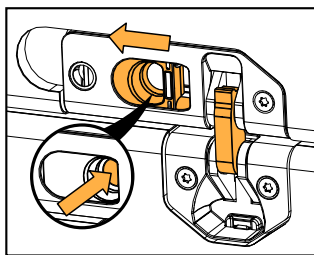

4. Switch the enclosures and repeat the procedure.

## Acoustical check

---

### Enclosure check

-  **This feature is available on:**  
 LA4X  
 LA12X

ENCLOSURE CHECK measures impedance at the reference frequencies for the connected loudspeaker family. The measured impedance is compared to the expected range allowing for fast detection of loudspeakers presenting circuit continuity issues.

-  The results can be used for preliminary diagnosis but cannot replace a comprehensive quality control.

### Prerequisite

-  **ENCLOSURE CHECK measurements can only be reliable if the following requirements are met:**

Environment and temperature:

- Ambient temperature must be comprised between 0 °C / 32 °F and 40 °C / 104 °F. Ideal temperature is 20 °C / 68 °F.
- Enclosures must be at room temperature. If warm from a recent high level use or recently moved from a cold environment, let the loudspeakers reach room temperature before starting.

Enclosures:

- Enclosures must be included in the embedded factory preset library.
- Enclosures must be in nominal operating conditions:
  - Remove covers or dollies obstructing the loudspeakers or the vents.
  - Check for obvious physical damage or air leak: visually inspect the grill, gasket, cabinet, and connector plate for loose, missing or damaged parts.

Connection:

- Use only 10 m / 30 ft 4 mm<sup>2</sup> / AWG 11 speaker cables.
- Do not connect enclosures in parallel.

Amplified controllers:

- LA4X must run at least firmware version 1.1.0.
- LA4X load sensors must be calibrated. Refer to the **Load Sensor Calibration Tool** technical bulletin for more information.
- LA4X must warm up for at least 10 minutes after power up. Do not power off, reboot or switch to standby mode to avoid resetting the countdown.
- Load a preset corresponding to the connected loudspeaker's family. Presets from the user memories may be used on condition they are made of presets supported in the embedded factory preset library.

### Procedure

1. Power up the amplified controller. Let LA4X warm up for at least 10 minutes.
2. Connect the loudspeaker enclosures to the amplified controller.
3. Load a preset from or built from the embedded library corresponding to the connected loudspeaker family.
4. On the amplified controller, use the encoder wheel to select **MONITORING & INFO**. Press the OK key or the encoder wheel to validate.
5. Use the encoder wheel to select **ENCLOSURE CHECK**.



#### **Beware of sound levels.**

Although the sound pressure levels generated for the ENCLOSURE CHECK are moderate, do not stay within close proximity of the loudspeakers and consider wearing ear protection.

6. Press the OK key or the encoder wheel to launch the ENCLOSURE CHECK.

The amplified controller generates short sinusoidal signals simultaneously for each connected output.

The amplified controller displays the results for each output.

**7.** Depending on the displayed results, follow the instructions in the table.

| result | interpretation                                  | instructions  |
|--------|---|---|
| OK     | measured impedance is within expected range     | enclosure is in working order electrically  |
| ?      | unsupported preset family                       | only supported enclosures should be tested  |
| NC     | Not Connected                                   | if cables are connected:<br><b>a.</b> inspect the cables and connections<br><b>b.</b> go to step 8 (p.72)   |
| NOK    | measured impedance is not within expected range | <b>a.</b> check that all the prerequisites are met, in particular that the loaded preset corresponds to the connected speaker's family<br><b>b.</b> inspect the cables and connections<br><b>c.</b> go to step 8 (p.72) |
| UNDEF  | measured impedance is undefined                 |   |

**8.** Under NC, NOK and UNDEF results, press and hold the corresponding OUT key.

The amplified controller displays:

- the tested frequencies,
- information on the measured impedance:
  - OPEN for open circuit (found in NC results),
  - SHORT for short circuit (found in NOK results), or
  - a percentage of variation from the expected range (found in NOK and UNDEF results)
- the number of operational transducers out of the total

 Low variations from the expected range are acceptable: displayed percentage can be different from 0 and all transducers considered operational.

## Listening test

| enclosure | preset     | usable bandwidth |
|-----------|------------|------------------|
| A15 Focus | [A15]      | 41 Hz - 20 kHz   |
| A15 Wide  | [A15]      | 42 Hz - 20 kHz   |
| KS21      | [KS21_100] | 31 Hz - 100 Hz   |

### Procedure

1. Load the preset on an LA4X / LA8 / LA12X amplified controller.
2. Connect a sinus generator to the amplified controller.



#### **Risk of hearing damage**

Set a low sound level to start and use ear protection to adjust before testing.

3. Scan the bandwidth focusing on the usable range.  
The sound should remain pure and free of unwanted noise.

### Troubleshooting for LF speakers

One or more LF speaker produces distorted, buzzing, rubbing, clicking, muffled or weak sound.

#### Possible causes

- The screws are not tightened with the appropriate torque.
- There is an air leak in the gasket.
- There is dust on the cone.
- The cone is damaged.
- The surround is torn or delaminated.
- The voice coil or the spider is damaged.

### Procedure

1. Perform the speaker disassembly procedure.
2. Visually inspect the cables and the connectors.
3. Visually inspect the speaker cone, the voice coil and the spider.

If any damage is visible, replace the speaker.

4. Carefully clean the speaker with a dry cloth.
5. Perform the reassembly procedure.  
Replace the speaker gasket and the screws.  
Apply the recommended torque.

6. Repeat the listening test.

If the problem persists, replace the speaker.

## Troubleshooting for HF drivers

One or more HF driver produces high-frequency harmonic distortions, strange vibrations or weak sound.

### Possible causes

- There are foreign particles on the air gap.
- The diaphragm is not centered correctly.
- The screws used for reassembly are too loose.
- The diaphragm is damaged.

### Procedure

1. Perform the diaphragm disassembly procedure.
2. Visually inspect the diaphragm and the voice coil.  
If any damage is visible, replace the diaphragm.
3. Clean the air gap thoroughly.  
Use double-face adhesive tape to remove any particles.
4. Perform the diaphragm reassembly procedure.  
Apply the recommended torque.
5. Repeat the listening test.  
If the problem persists, replace the driver.



# Rigging procedures

## Flying

### Flying a vertical array with A15-BUMP/A15-RIGBAR

|                                |   |
|--------------------------------|---|
| <b>Type of deployment</b>      | flown array   |
| <b>Rigging accessory</b>       | A15-BUMP/A15-RIGBAR<br>2 x Ø12 mm shackle WLL 1 t (provided)<br>M-BAR (optional, with A15-BUMP)<br>Flight case (optional, see <a href="#">Alternative procedure with flight cases</a> (p.78)) |
| <b>Min number of operators</b> | 2   |

**⚠ Risk of falling objects**  
Verify that no unattached items remain on the product or assembly.

**⚠ Secondary safety**  
Use available holes on the rigging accessories to implement a secondary safety.

**i Array orientation**  
Under A15-BUMP and A15-RIGBAR, the enclosure HF section can be oriented both ways.  
Under KS21, the HF section is on the same side as the subwoofer vent.

#### A15 Wide/Focus array

##### About this task

If the A15 Wide/Focus enclosures are stored in flight cases, refer to [Alternative procedure with flight cases](#) (p.78).

##### Procedure

1. Stack up to three enclosures.

Connect each enclosure on both sides before adding the new one.

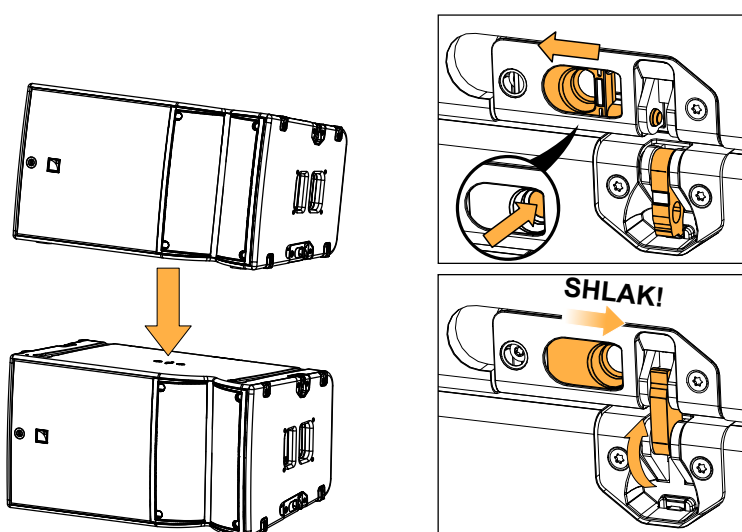



Optionally, secure an M-BAR on A15-BUMP to extend the site angle capability. Use the provided 3/8" ball-locking pins.

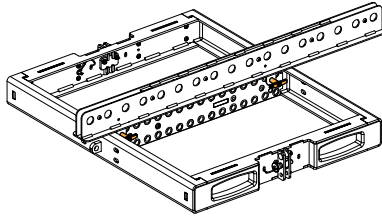

2. Secure A15-BUMP or A15-RIGBAR on top of the array.

**A15-BUMP**

Connect A15-BUMP to the top enclosure on both sides.

**A15-RIGBAR**

Connect A15-RIGBAR to the top enclosure on both sides.

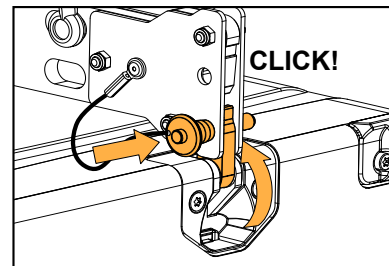
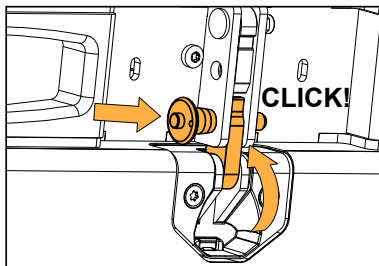
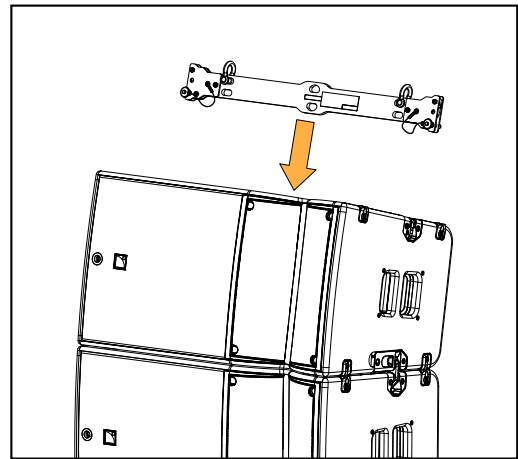
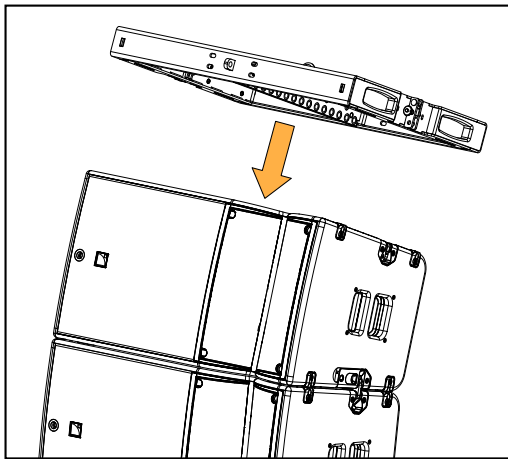

**Final check**

Visually check that no yellow labels are visible. Manually check that all linking points are secured.

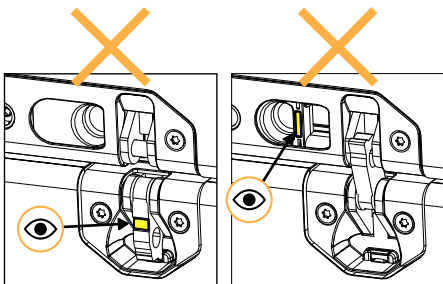

3. Select the pick-up point and raise the array.

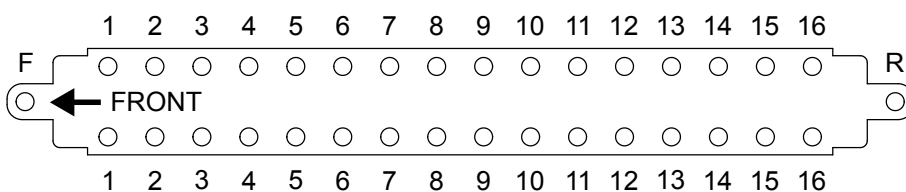

**!** **This step requires two operators.**

Hold the enclosure by the handle until the rigging system is locked.

4. One by one, secure additional enclosures under the array.

Connect each enclosure on both sides before adding the next one.

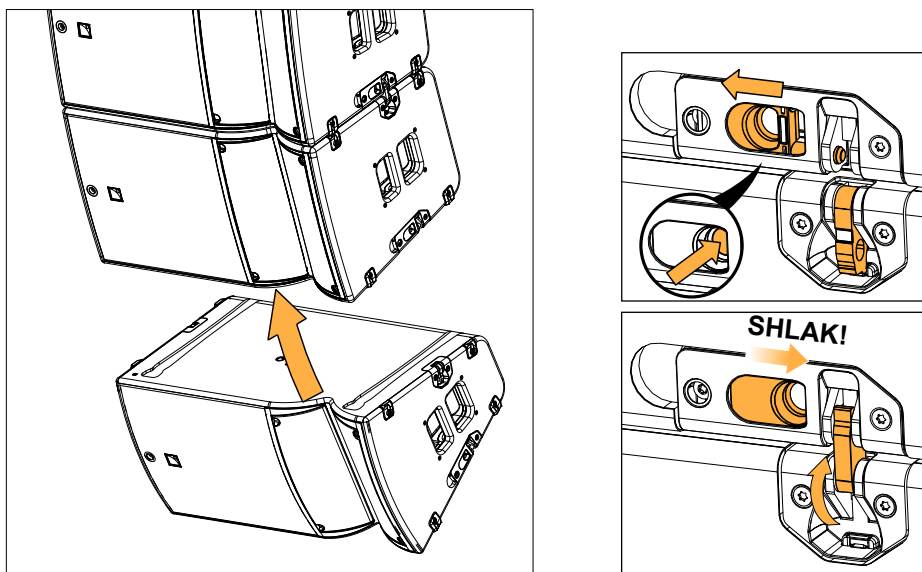

**!** **Final check**

Visually check that no yellow labels are visible.

Manually check that all linking points are secured.

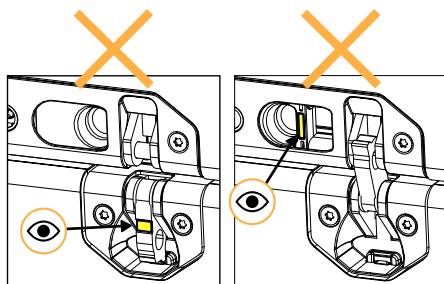

## Alternative procedure with flight cases

### Procedure

1. Bring a flight case with two A15 Wide/Focus at the rigging location and remove the top part.

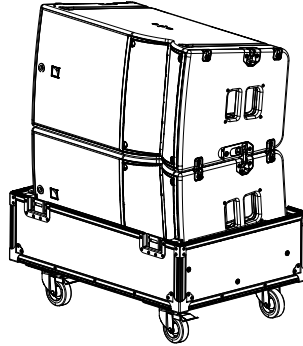

Optionally, secure an M-BAR on A15-BUMP to extend the site angle capability. Use the provided 3/8" ball-locking pins.

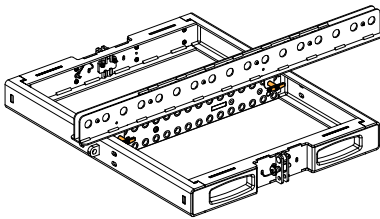

2. Secure A15-BUMP or A15-RIGBAR on top of the array.

#### A15-BUMP

Connect A15-BUMP to the top enclosure on both sides.

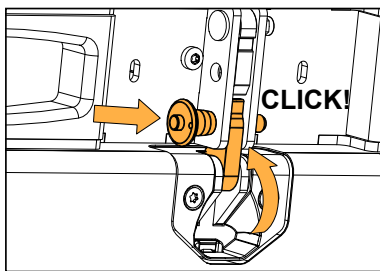
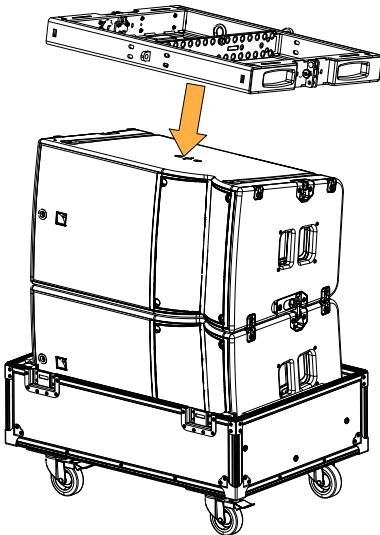

#### A15-RIGBAR

Connect A15-RIGBAR to the top enclosure on both sides.

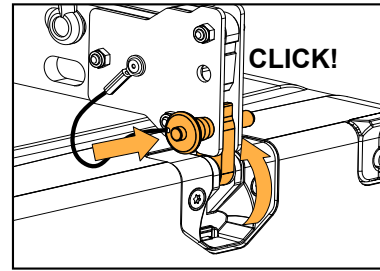
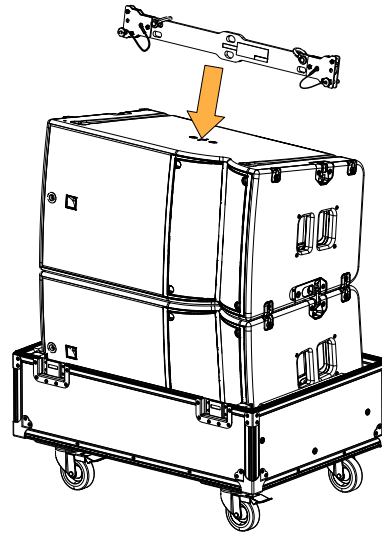



**Final check**

Visually check that no yellow labels are visible.  
Manually check that all linking points are secured.

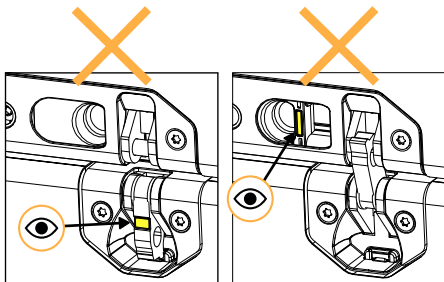

3. Select the pick-up point and raise the array.

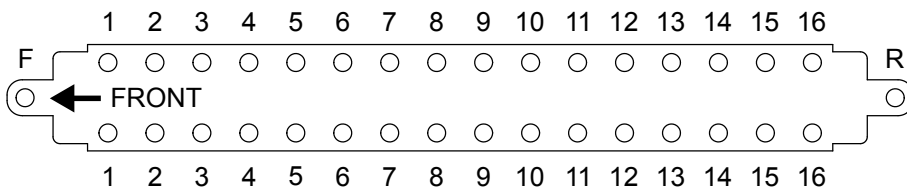

4. Bring another flight case with two enclosures under the array.



**This step requires two operators.**

Hold the enclosure by the handle until the rigging system is locked.

5. One by one, remove the enclosures from the flight case and secure them under the array.

Connect each enclosure on both sides before adding the next one.

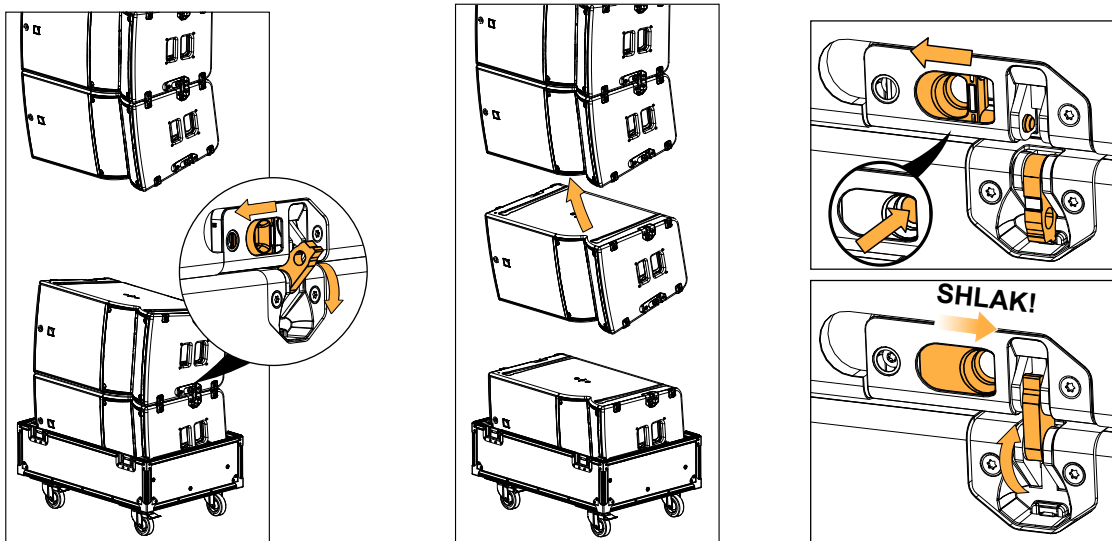

**Final check**

Visually check that no yellow labels are visible.  
Manually check that all linking points are secured.

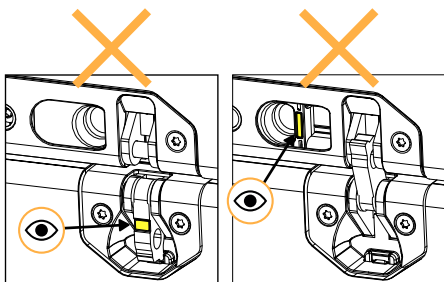

## KS21 and A15 Wide/Focus array

### About this task

#### Flying hybrid arrays

The KS21 subwoofers must always be on top of the array.  
Refer to Soundvision for maximum configurations.

### Procedure

1. Prepare a stack of KS21.

Connect each enclosure on both sides before adding the new one.

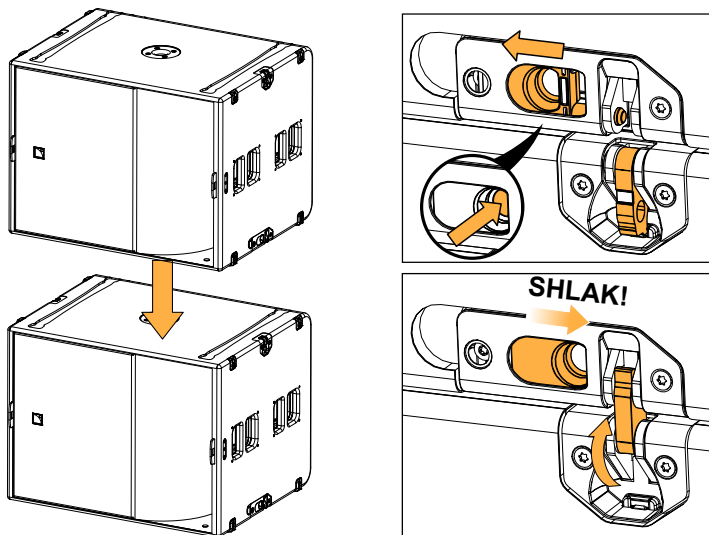

2. Secure A15-BUMP or A15-RIGBAR on top of the array.

#### A15-BUMP

Connect A15-BUMP to the top KS21 on both sides.

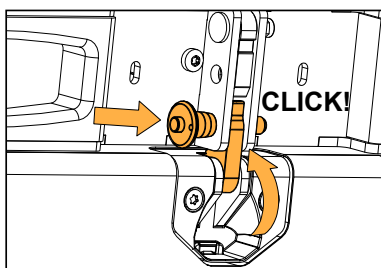
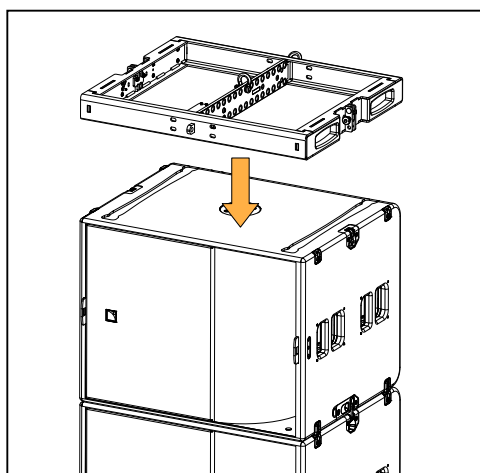

#### A15-RIGBAR

Connect A15-RIGBAR to the top KS21 on both sides.

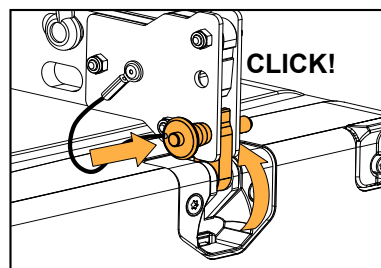
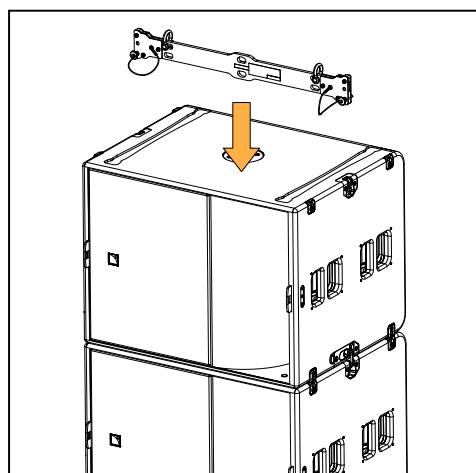



**Final check**

Visually check that no yellow labels are visible.  
Manually check that all linking points are secured.

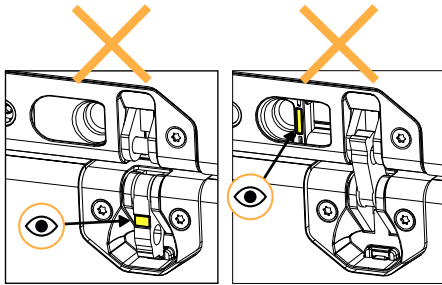

3. Select the pickup point and raise the array.

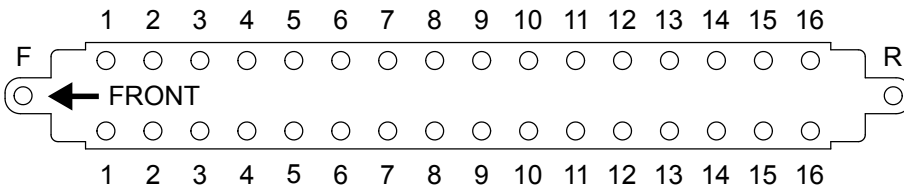

4. Add additional enclosures under the array:

**KS21**

Lower the array onto a KS21 or a stack of KS21 on KS21-CHARIOT.

Align the runners and the tracks.

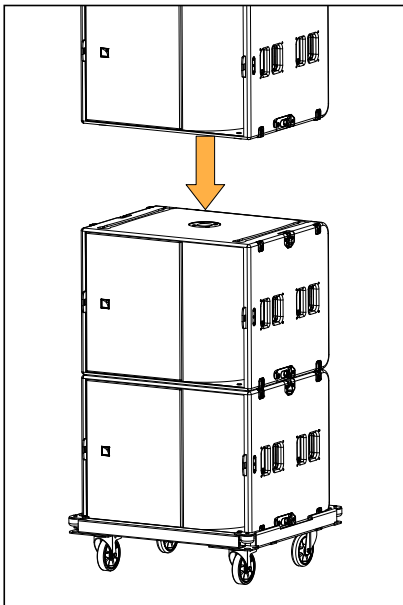

Unlock the KS21-CHARIOT rigging arms.

**A15 Focus or A15 Wide**



**This step requires two operators.**

Hold the enclosure by the handle until the rigging system is locked.

One by one, lift the enclosures and secure them under the array.

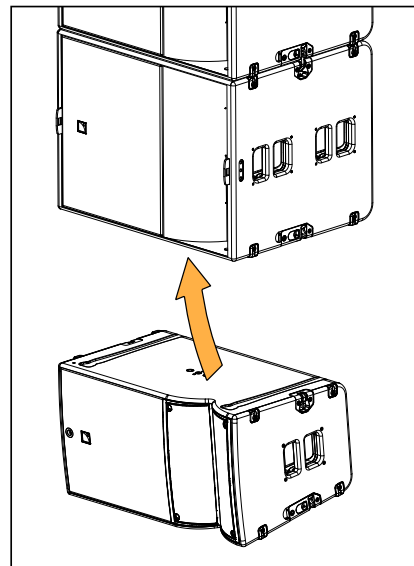

5. Connect the enclosure on both sides before adding the next one.

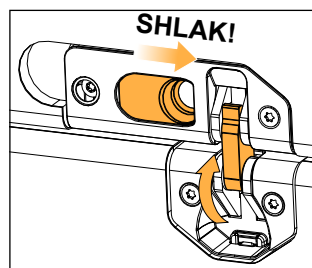
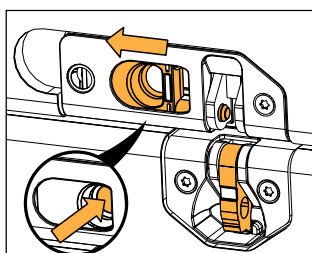



### Final check

Visually check that no yellow labels are visible.  
Manually check that all linking points are secured.

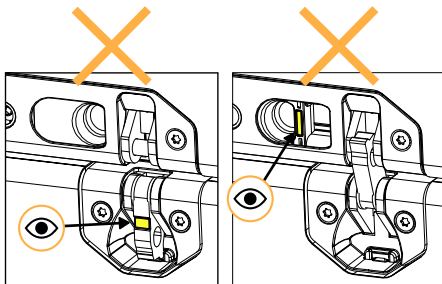

## Disassembly

### Removing a stack of KS21

#### Procedure

1. Position a KS21-CHARIOT under the array.

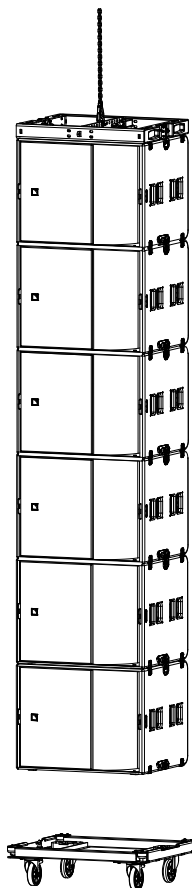





### Prepare KS21-CHARIOT

Make sure the KS21-CHARIOT brakes are not engaged.

Make sure the KS21-CHARIOT rigging arms are in the open position.

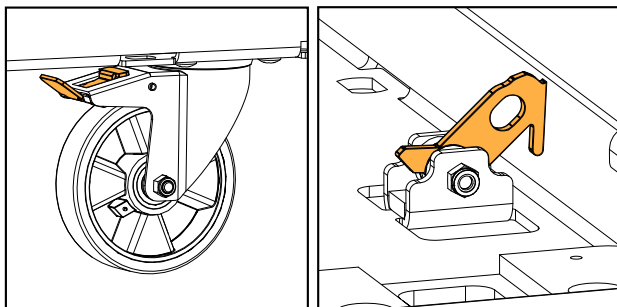

Proceed slowly when lowering the array.

2. Lower the array until it rests on KS21-CHARIOT.
3. Secure the bottom enclosure to KS21-CHARIOT.

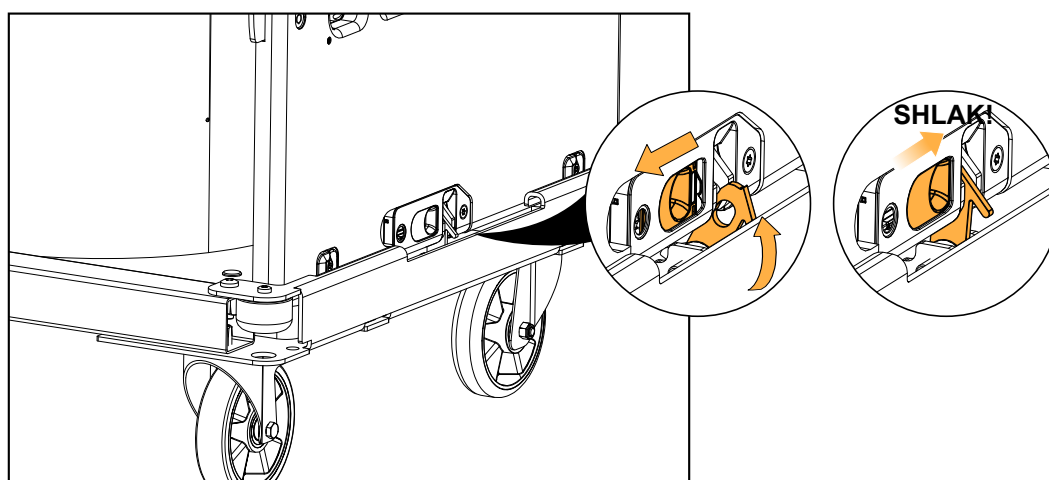

4. Disconnect a stack from the array on both sides.

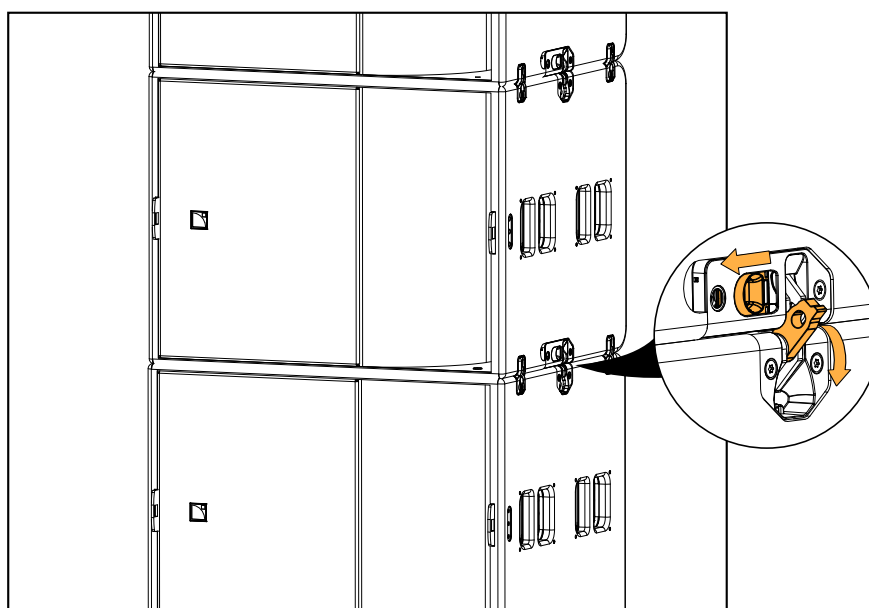

Make sure both linking points are disconnected before lifting the array.

5. Lift the assembly and put the stack aside.
6. Repeat the procedure.

## Adding a pullback with A15-BUMP/A15-RIGBAR

|                                |  |
|--------------------------------|--|
| <b>Type of deployment</b>      | flown array with pullback                                    |
| <b>Rigging accessory</b>       | A15-BUMP/A15-RIGBAR<br>1 x Ø12 mm shackle WLL 1 t (provided) |
| <b>Min number of operators</b> | 2  |

**⚠ Risk of falling objects**  
Verify that no unattached items remain on the product or assembly.

### Assembly

#### Procedure

1. Prepare a vertical array as described in [Flying a vertical array with A15-BUMP/A15-RIGBAR](#) (p.75).
2. Raise the array until the bottom enclosure is accessible.
3. Secure A15-BUMP or A15-RIGBAR under the array.

#### A15-BUMP

Connect A15-BUMP to the bottom enclosure on both sides.

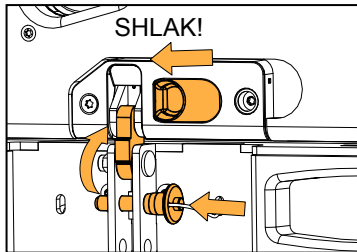
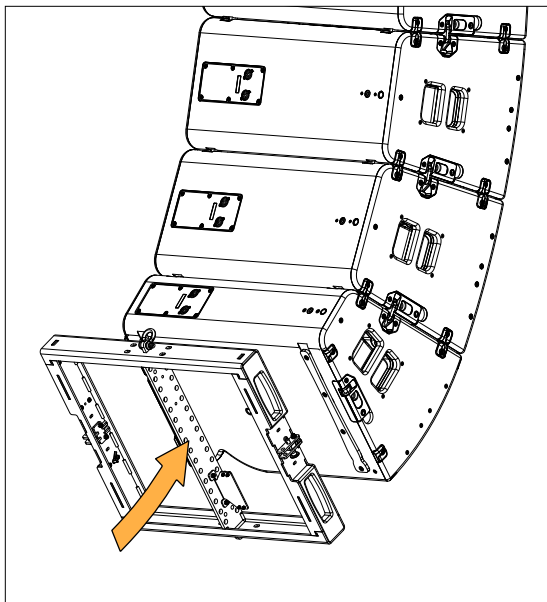

#### A15-RIGBAR

Connect A15-RIGBAR to the bottom enclosure on both sides.

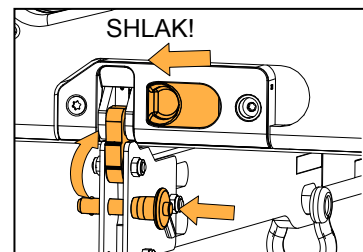
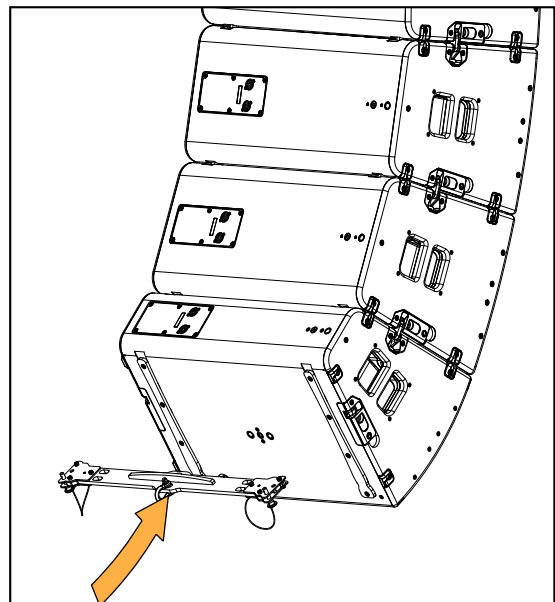

**Final check**

Visually check that no yellow labels are visible.

Manually check that all linking points are secured.

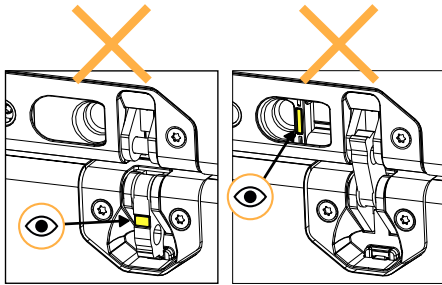

- 4.** Secure a shackle to A15-RIGBAR or to pickup point R on A15-BUMP and lift it with an additional motor.

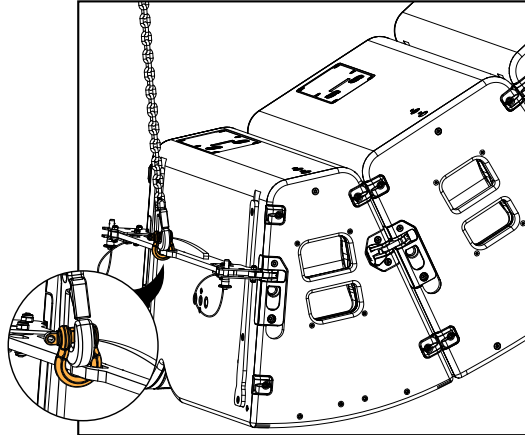
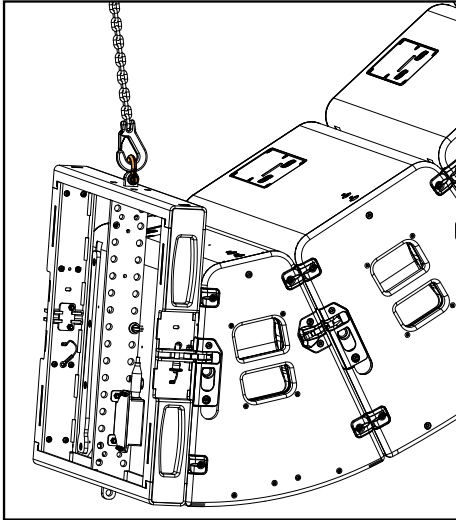

## Flying a radial array with A15-LIFT

|                                |  |
|--------------------------------|--|
| <b>Type of deployment</b>      | flown radial array   |
| <b>Rigging accessories</b>     | one A15-LIFT for three enclosures<br>LA-SLING2T or a bridle (optional)<br>Ø12 mm shackles WLL 1 t (provided) |
| <b>Min number of operators</b> | 2  |

- ⚠ Risk of falling objects**  
Verify that no unattached items remain on the product or assembly.
- ⚠ Additional safety with A15-LIFT**  
On each enclosure on which A15-LIFT is secured, secure a DIN580 eye bolt to the dedicated insert to implement a secondary safety.  
Use a shackle and a steel wire rope. Make sure the steel rope is as tensed as possible without bearing the load.

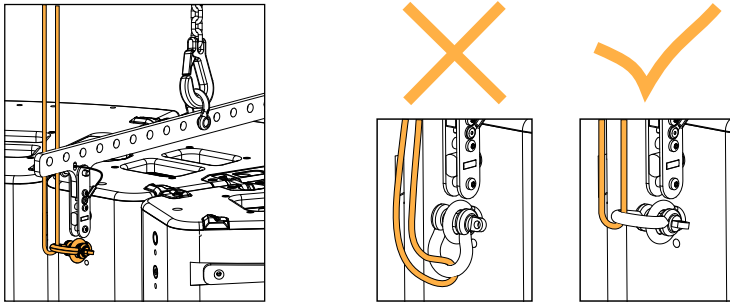

- ⚠ A15-LIFT quantity and position**  
Use one A15-LIFT for up to three enclosures in the array.  
Do not leave more than two adjacent enclosures unsupported.  
Refer to [APPENDIX A: Authorized configurations with A15-LIFT](#) (p.150).

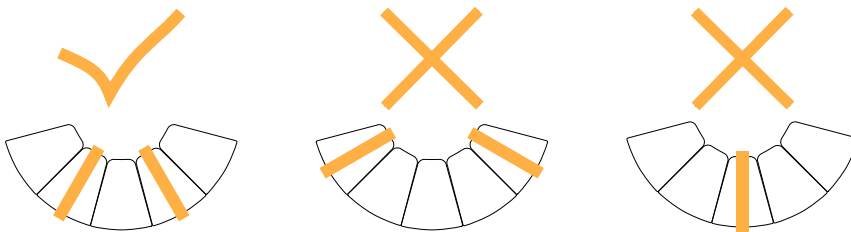

- ⚠ Risk of tilting**  
When using a single motor or a bridle, make sure the array is symmetrical.

## Assembly

### Procedure

1. Place the enclosures (logo on top) at the lifting location.

Optionally, prepare blocks of up to three enclosures. Refer to [Preparing a block of enclosures](#) (p.90).

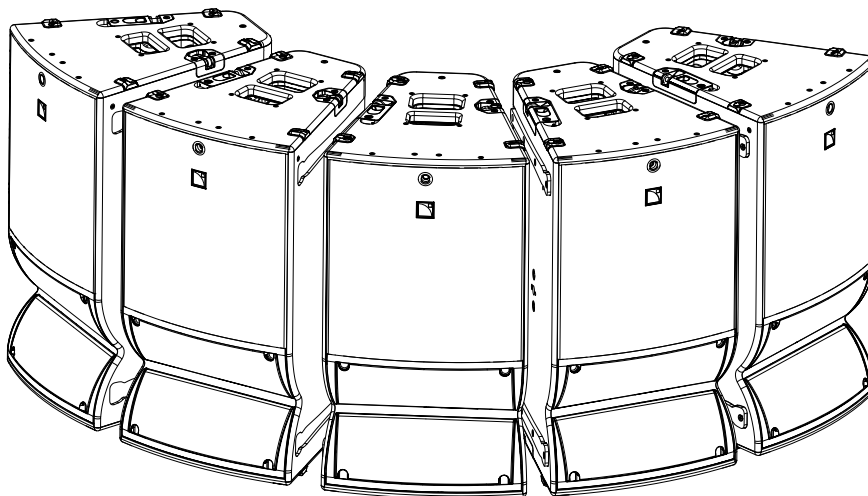

2. Connect the enclosures at the top.

Pull the enclosures together to align the rigging.

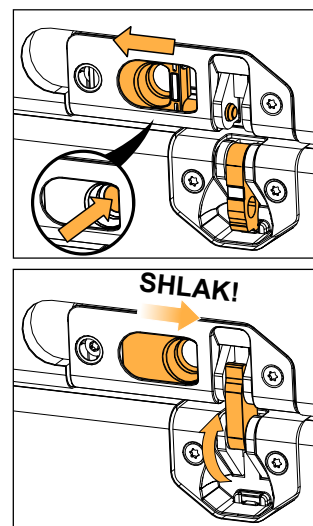
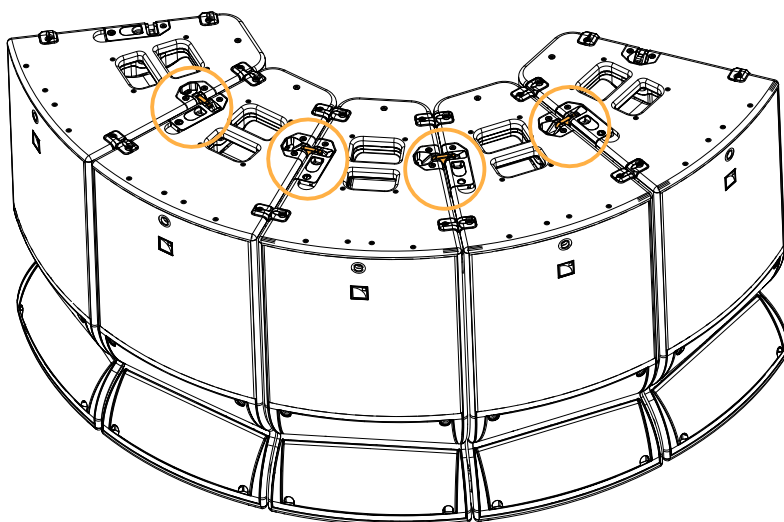

#### Final check

Visually check that no yellow labels are visible.  
Manually check that all linking points are secured.

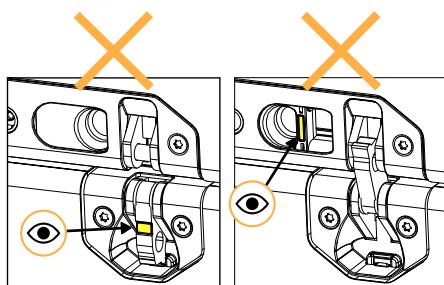

**3. Secure the A15-LIFT bars on the array.**

a) Disconnect the ball-locking pin at the rear of A15-LIFT.

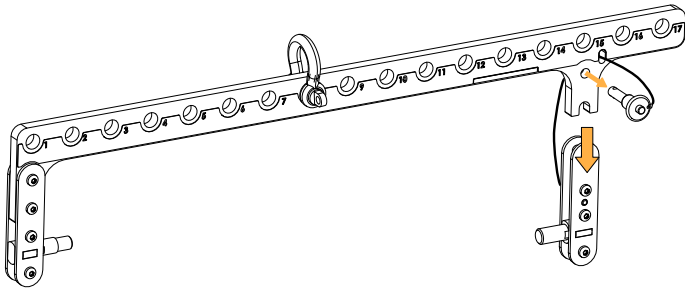

b) Insert the stub at the front of the enclosure.

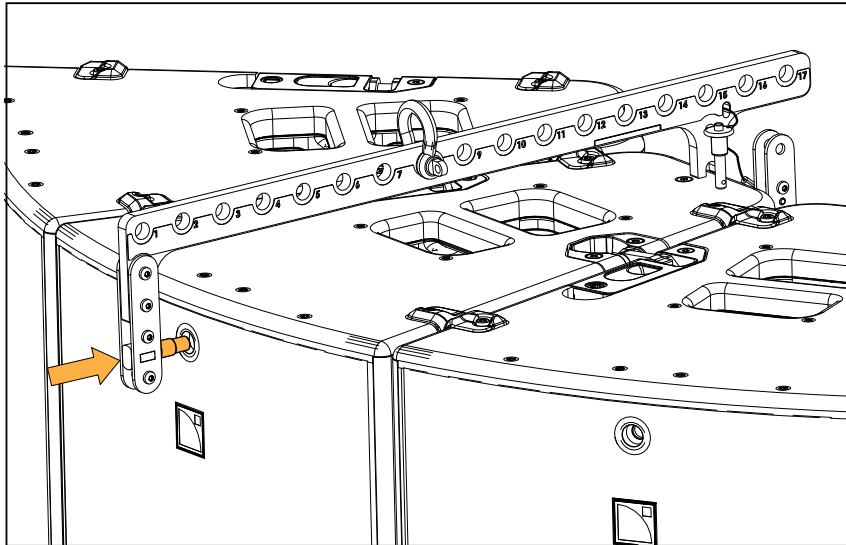

c) Insert the stub at the rear and secure the ball-locking pin.

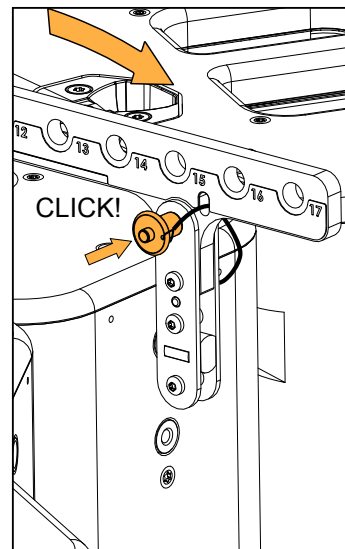
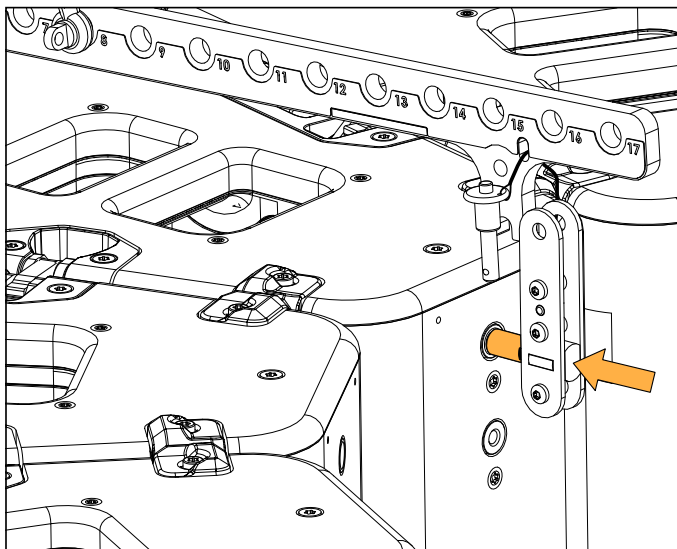

4. On each A15-LIFT, secure a shackle to the **setup point** (hole 11).

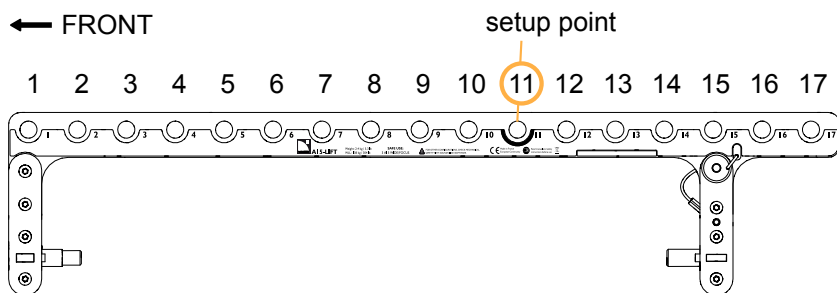

**Make sure the pickup points are on hole 11 before lifting the array.**

5. Raise the array until the bottom rigging is accessible.



For this operation, stand behind the array.

6. Connect the enclosures at the bottom.

Pull the enclosures together to align the rigging.

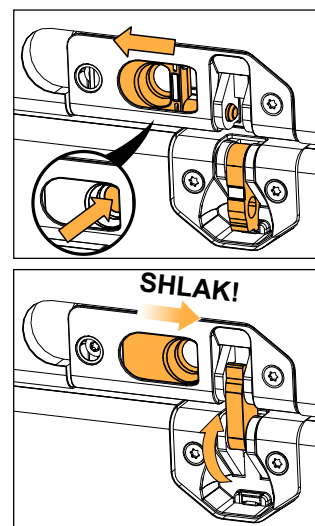
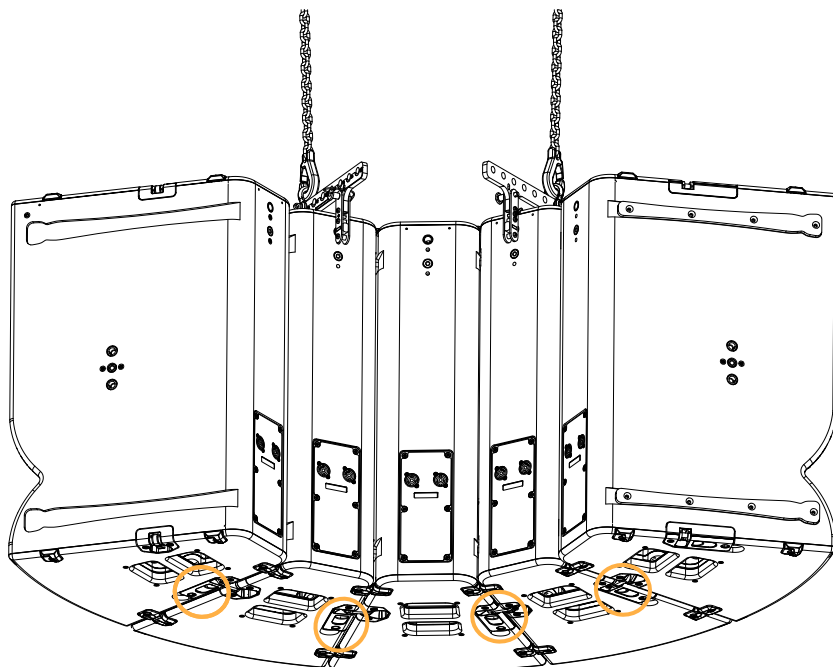

7. Lower the array to select the desired pickup points.



**A15-LIFT pickup point**

Select the same pickup point on each A15-LIFT within an array of up to 6 enclosures.

For larger arrays, refer to [Radial arrays of 7 enclosures and more](#) (p.151).

## Preparing a block of enclosures

### About this task

**⚠ This procedure is optional and requires two operators**  
 A single operator must assemble the enclosures one by one. Refer to [Assembly](#) (p.87).

### Procedure

1. Separate the array into blocks of two or three enclosures.  
 Connect each enclosure on both sides before adding the new one.

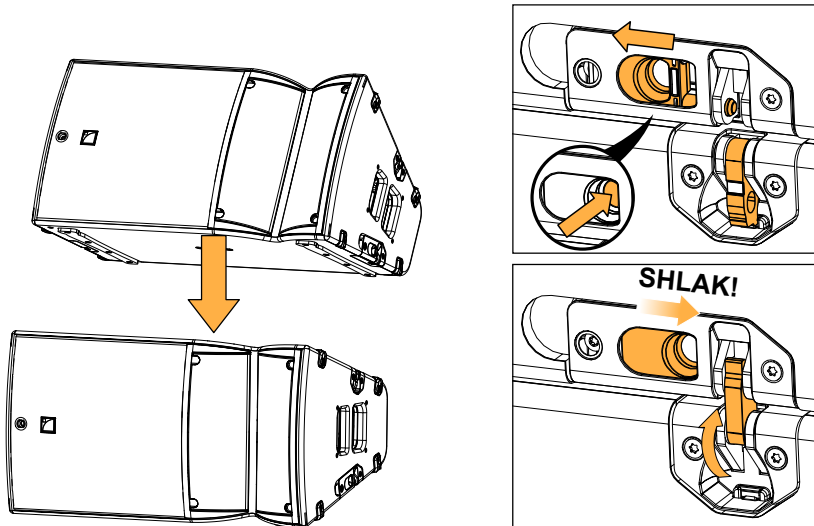

**⚠ This step requires two operators.**

**⚠** Make sure all unused rigging arms are in storage position.

2. Position the enclosure blocks upright (logo on top) in two steps.

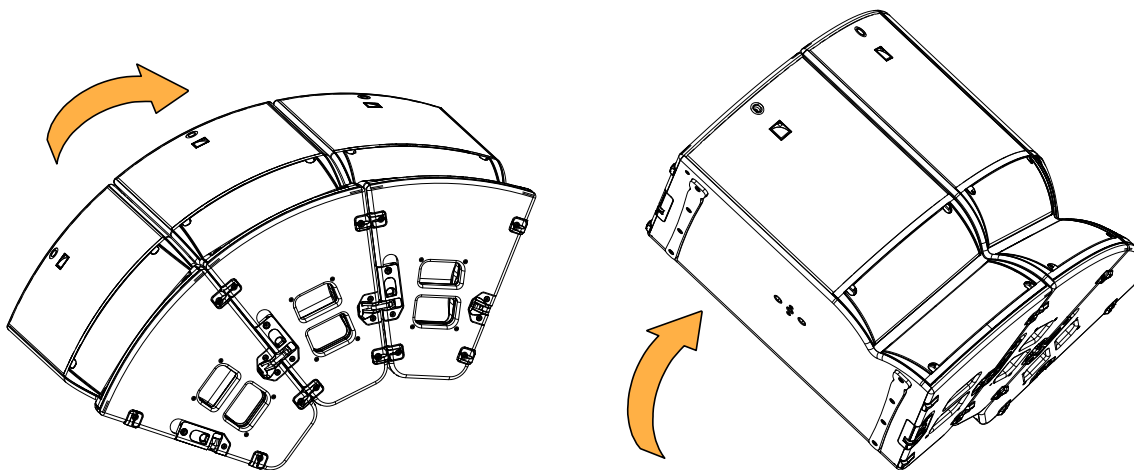

Tilt the enclosures on the rear.

Tilt the enclosures upright.

3. Proceed as described in [Assembly](#) (p.87).



## Disassembly

### Procedure

1. Lower the array to the ground.
2. On each A15-LIFT, move the shackle to the **setup point** (hole 11).

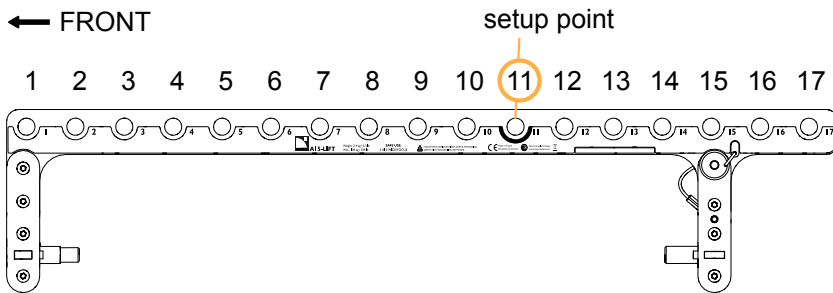

**Make sure the pickup points are on hole 11 before lifting the array.**

3. Raise the array until the bottom rigging is accessible.

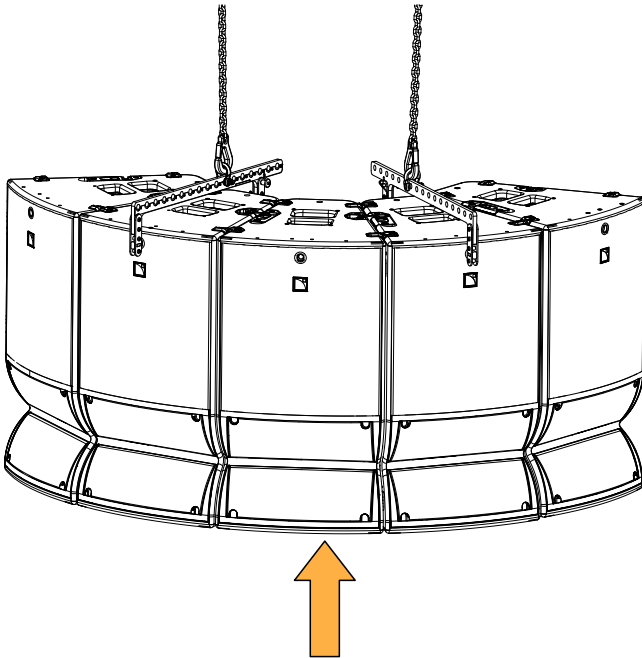

4. Disconnect the enclosures at the bottom.

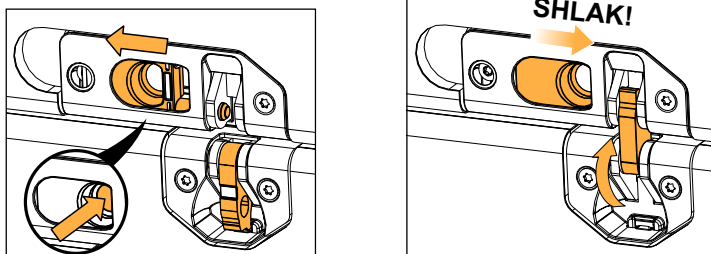

**Make sure all unused rigging arms are in storage position.**

5. Lower the array to the ground.

## Flying a single enclosure with X-BAR

|                                |  |
|--------------------------------|--|
| <b>Type of deployment</b>      | flown  |
| <b>Rigging accessories</b>     | X-BAR<br>1 x Ø12 mm shackle WLL 1 t (provided) or CLAMP250 |
| <b>Min number of operators</b> | 1  |

### Additional safety for flown arrays

When flying an enclosure or an array, use the M8 DIN580 threaded insert to implement a secondary safety.

### Realized site angles

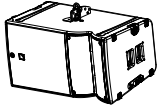
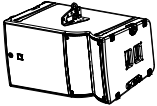
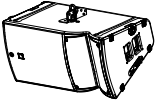
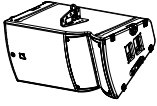
| X-BAR hole N° | realized site angle   |   |   |   |
|---------------|---|---|---|---|
|               | A15 Focus   |   | A15 Wide  |   |
|               | rear extension  | front extension   | rear extension  | front extension   |
|               |  |  |  |  |
| 1             | 8.4°  | -10°  | 6.9°  | -13.6°  |
| 2             | -0.5°   | -1°   | -2.8°   | -3.4°   |
| 3             | -9.4°   | 7.8°  | -13.2°  | 6.5°  |
| 4             | -18.5°  | 16.2°   | -23.7°  | 15.7°   |
| 5             | -27.5°  | 24.8°   | -34.6°  | 25.1°   |

## Assembly

### Procedure

1. Drive the X-BAR in the insert.

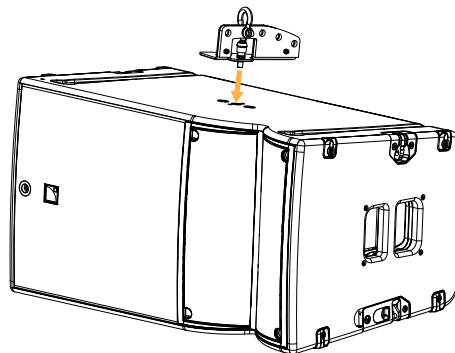

**2.** Rotate the X-BAR until perpendicular to the front grill.

Use the lodgings as reference points.

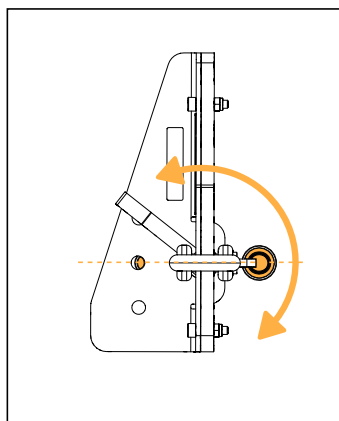

**3.** Tighten the X-BAR.

a) Lift the lever and rotate it counter-clockwise, release the lever and rotate it clockwise.

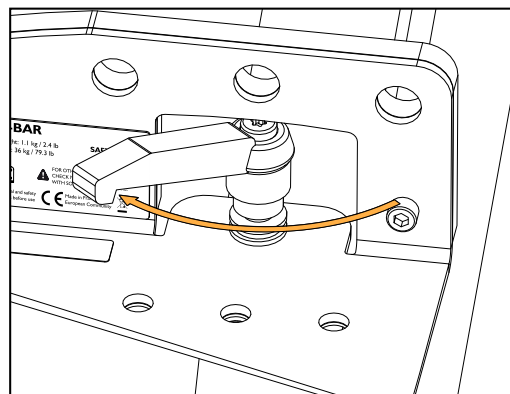
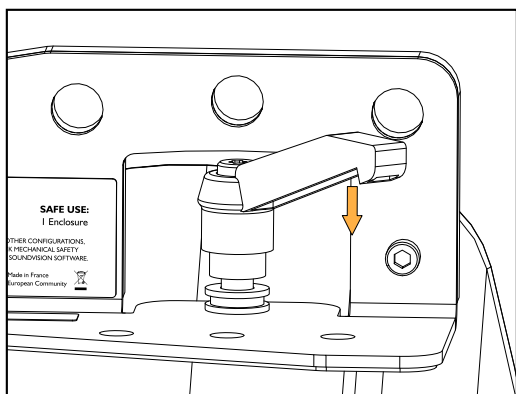
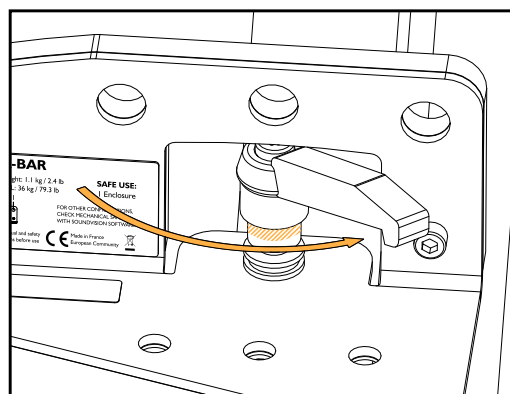
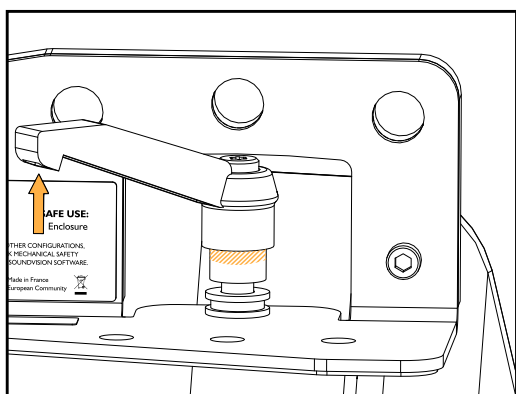

Repeat until the X-BAR is tightly secured.

b) Finally, store the lever on the right.

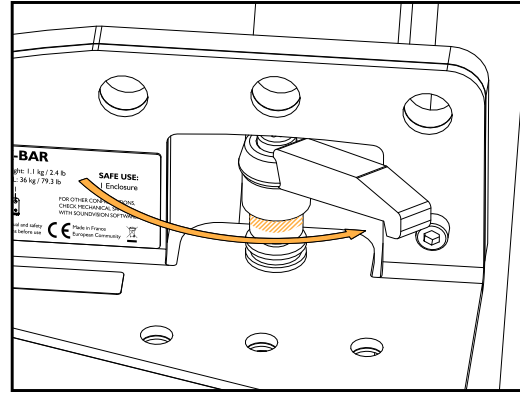
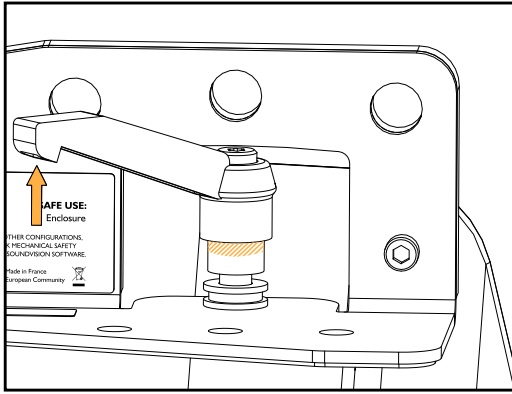

4. Select the site angle and secure a shackle or CLAMP250.

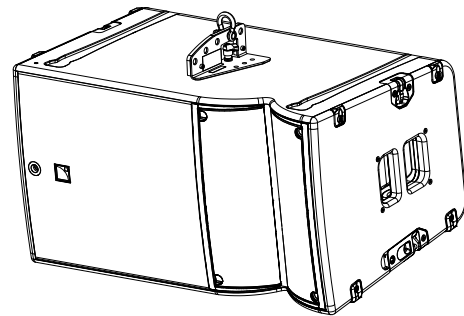
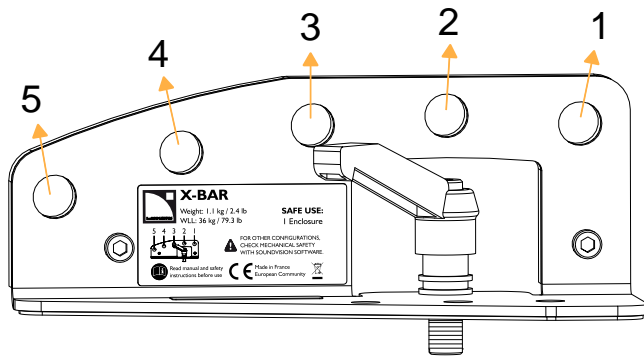

## Stacking

### Stacking A15 Wide/Focus on KS21 with A-TILT

|                                |                         |
|--------------------------------|-------------------------|
| <b>Type of deployment</b>      | stacked array           |
| <b>Rigging accessory</b>       | A-TILT<br>KS21-OUTRIG * |
| <b>Min number of operators</b> | 2                       |

**⚠ Risk of falling objects**  
Verify that no unattached items remain on the product or assembly.

**⚠ Do not use A-TILT in a flown array.**

**i** \* Alternatively, mount the KS21 array on KS21-CHARIOT and use K2-JACK to stabilize the array.  
Refer to [Attaching K2-JACK stabilizers to KS21-CHARIOT](#) (p.101).

#### Realized site angles

| selected angle on A-TILT | realized site angle |          |
|--------------------------|---------------------|----------|
|                          | A15 Focus           | A15 Wide |
| 12.5°                    | -7.5°               | +2.5°    |
| 15°                      | -10°                | 0°       |
| 17.5°                    | -12.5°              | -2.5°    |
| 20°                      | -15°                | -5°      |
| 22.5°                    | -17.5°              | -7.5°    |
| 25°                      | -20°                | -10°     |

## Assembly

### Procedure

- Secure KS21-OUTRIG under a KS21.  
Turn the KS21 upside-down to secure KS21-OUTRIG.

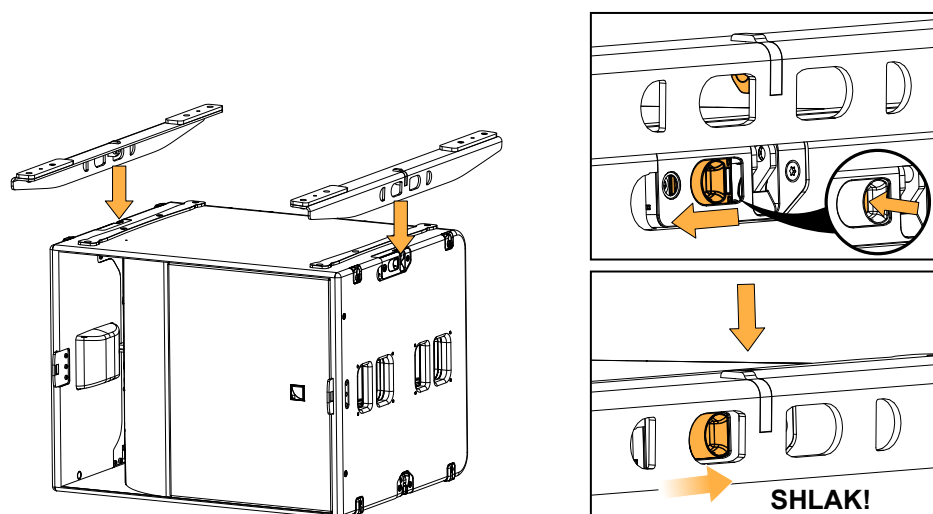

**2. Secure additional KS21 on top.**

Connect each enclosure on both sides before adding the new one.

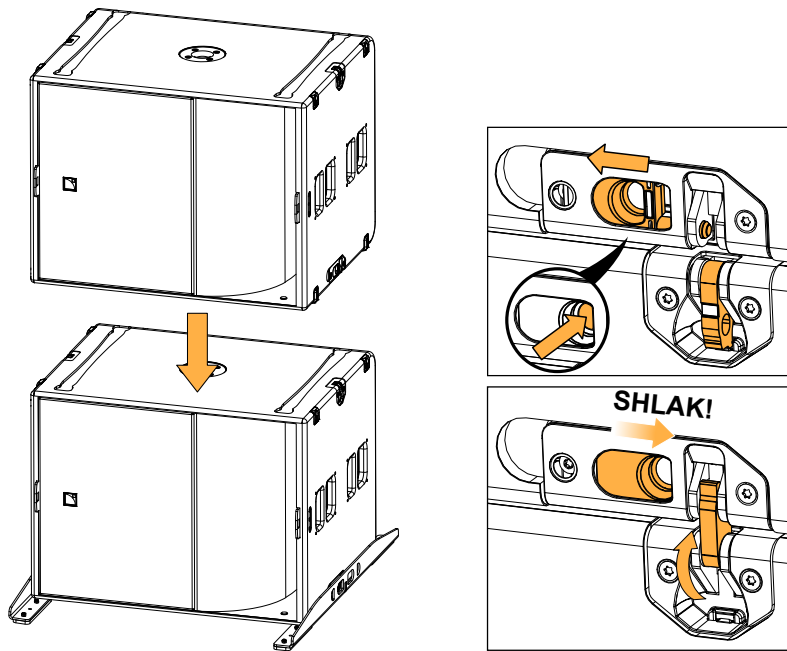

**3. Select the widest opening position on A-TILT (25°).**

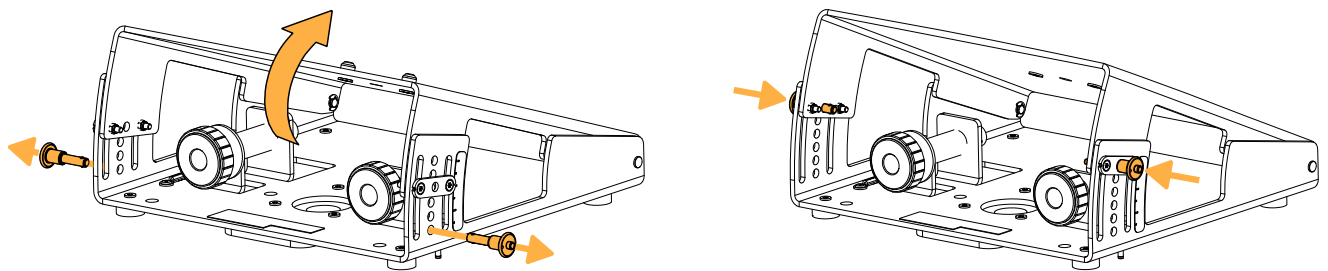

**4. Place A-TILT on A15 Wide/Focus, using the locating pins for positioning.**

Consider the final position of the enclosure.

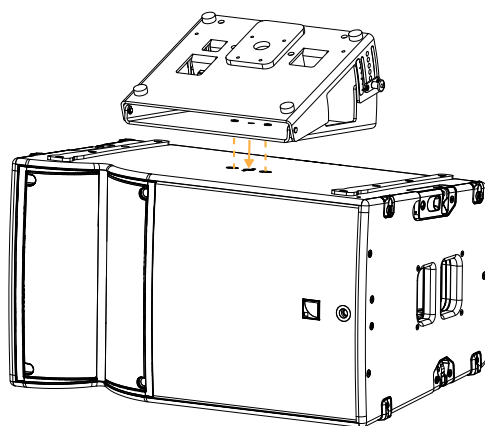

5. Secure A-TILT to the enclosure with the enclosure knob.

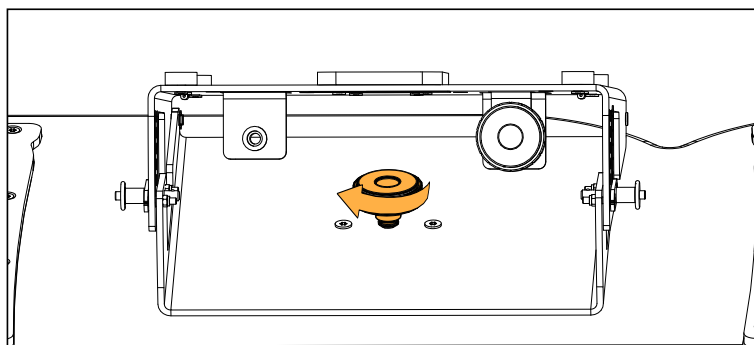
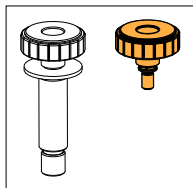

6. Place the assembly on KS21.

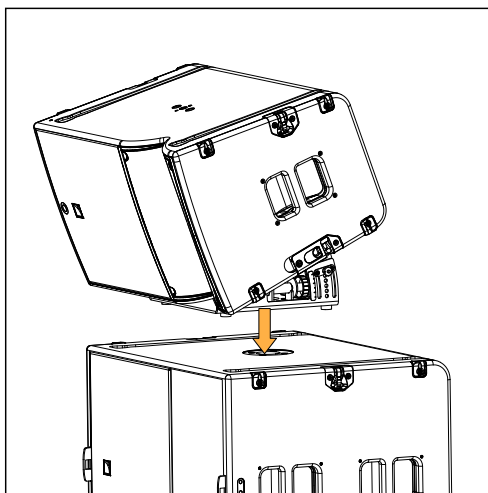

7. Adjust the position of A-TILT and secure the subwoofer knob inside the pole-mounting socket.

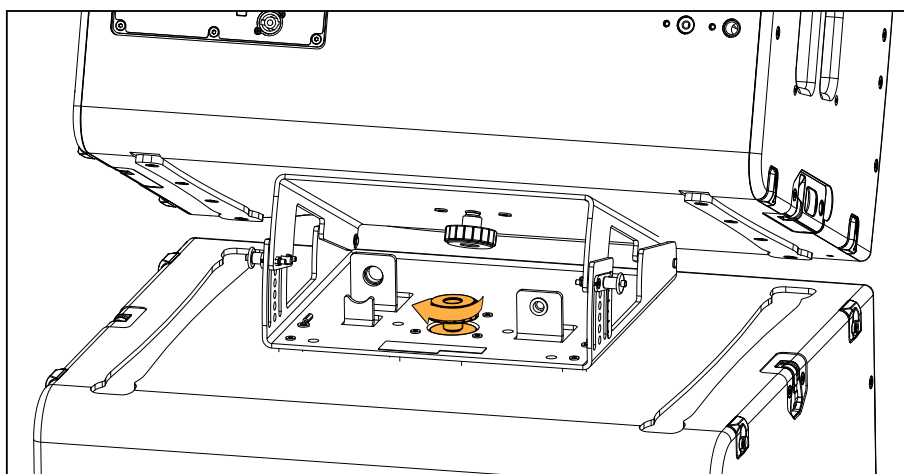
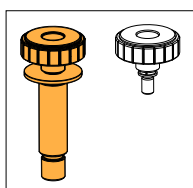



**Risk of crushing**

Hold the top enclosure when the angle pins are removed.  
Accompany the assembly movement downwards.

**8. Adjust the site angle.**

Insert the angle pins in the selected opening angle on both sides.

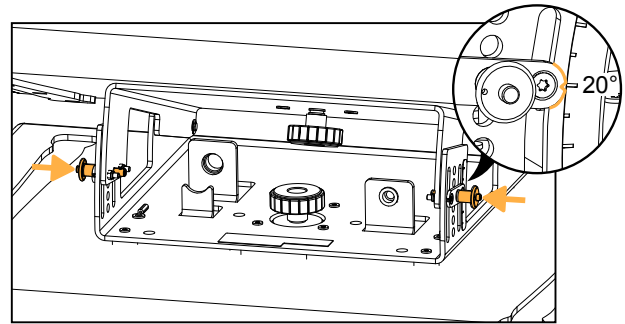
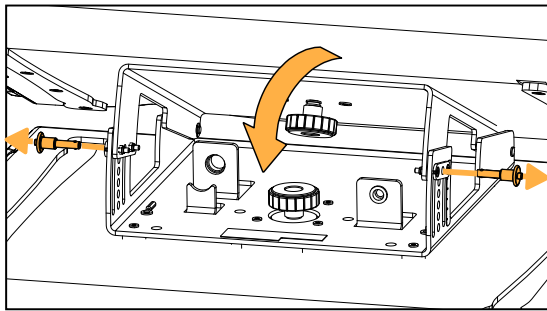

**9. Optionally, secure additional enclosures on top of the assembly.**

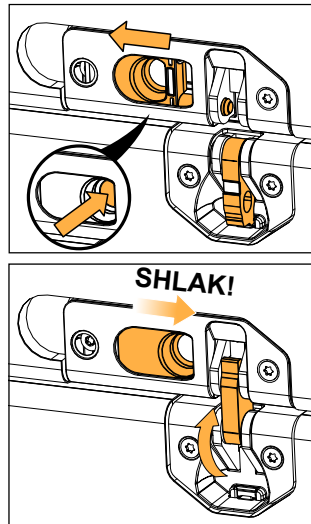
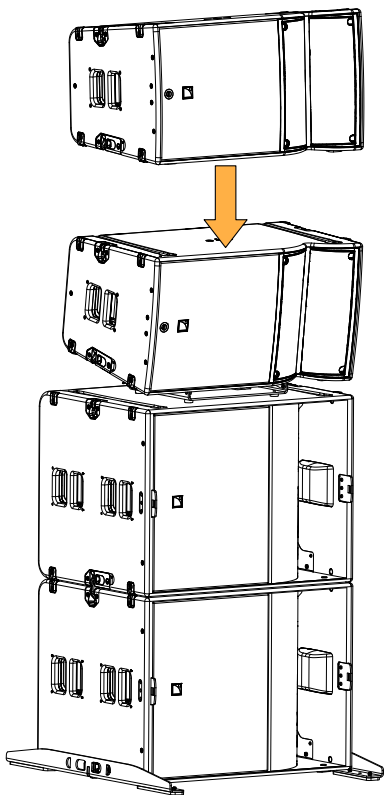

**Final check**

Visually check that no yellow labels are visible.  
Manually check that all linking points are secured.

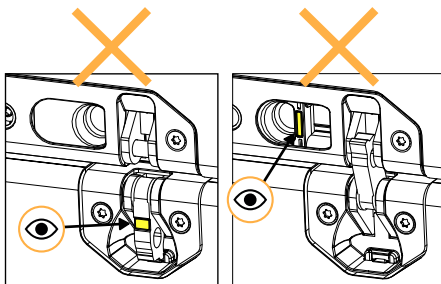



## Stacking KS21 on KS21-CHARIOT

|                                |               |
|--------------------------------|---------------|
| <b>Type of deployment</b>      | stacked array |
| <b>Rigging accessory</b>       | KS21-CHARIOT  |
| <b>Min number of operators</b> | 2             |

### Risk of falling objects

Verify that no unattached items remain on the product or assembly.

### Assembly

#### Procedure

1. Engage both brakes on KS21-CHARIOT.

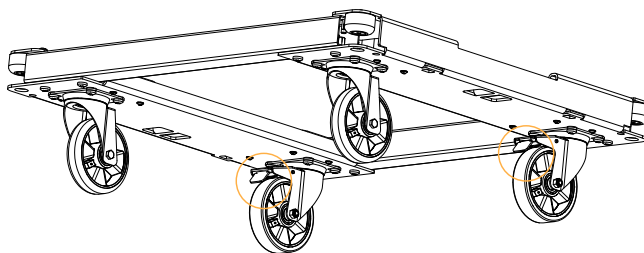

2. Place KS21 on KS21-CHARIOT and connect the two elements on both sides.

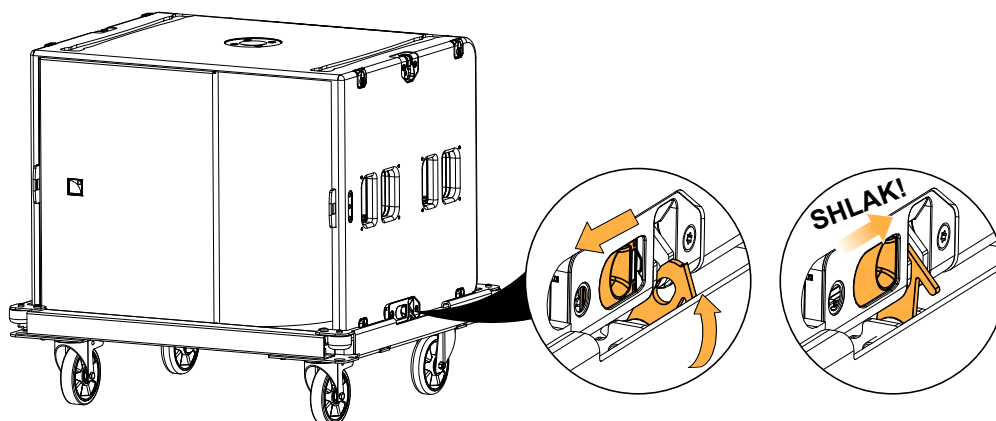

**3.** Secure another KS21 on the assembly.

Align the runners with the tracks.

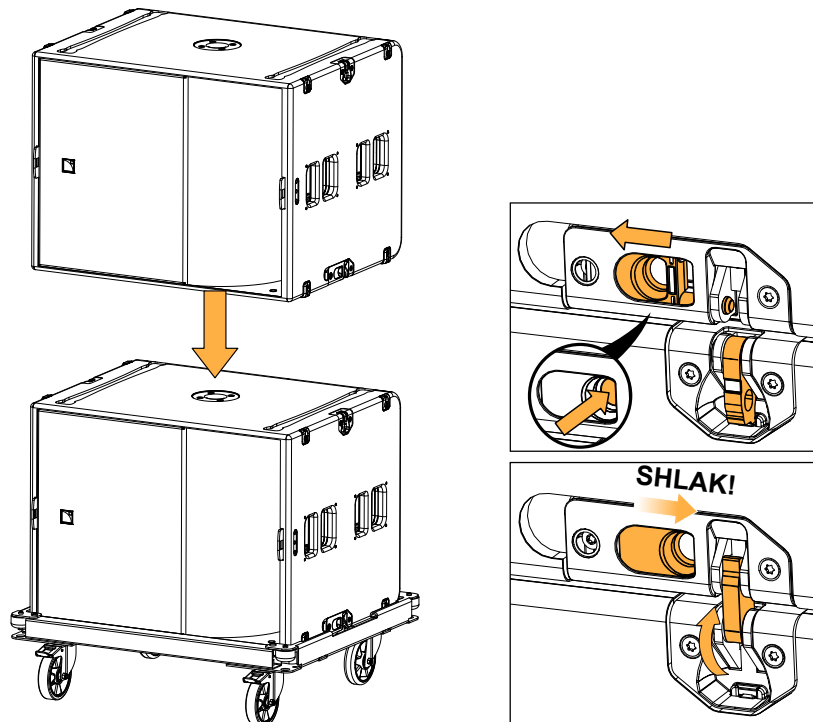

**4.** Repeat until the stack is complete.



**Final check**

Visually check that no yellow labels are visible.  
Manually check that all linking points are secured.

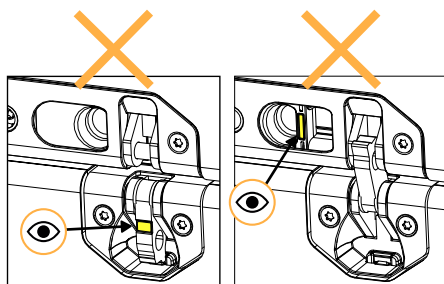

**5.** Disengage the brakes and position the stack at its final position.

**6.** Block the stack using both brakes.

## Attaching K2-JACK stabilizers to KS21-CHARIOT

|                                |                         |
|--------------------------------|-------------------------|
| <b>Type of deployment</b>      | stacked array           |
| <b>Rigging accessory</b>       | K2-JACK<br>KS21-CHARIOT |
| <b>Min number of operators</b> | 1                       |

### Assembly

#### Procedure

1. Attach the K2-JACK bars to KS21-CHARIOT on each side.
  - a) Open the locking handles to insert the studs.

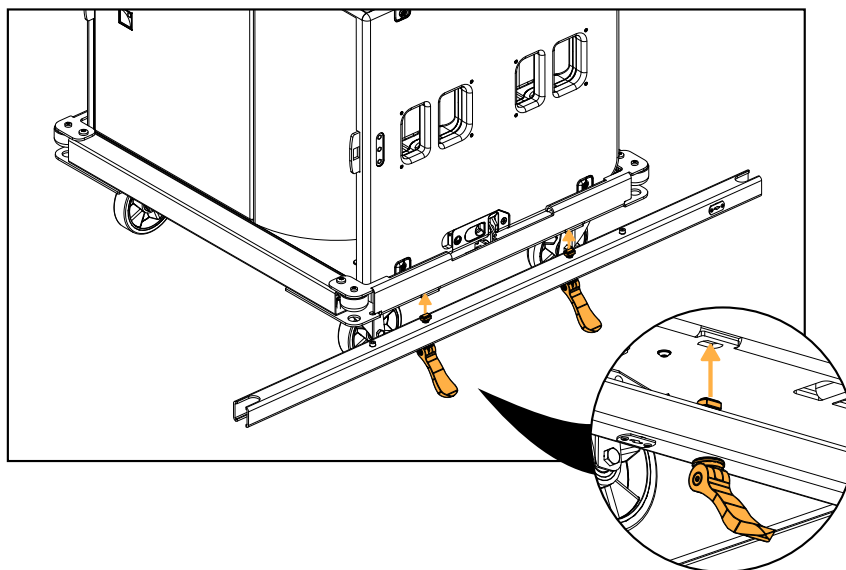

- b) Raise and turn the locking handles to secure the bars.

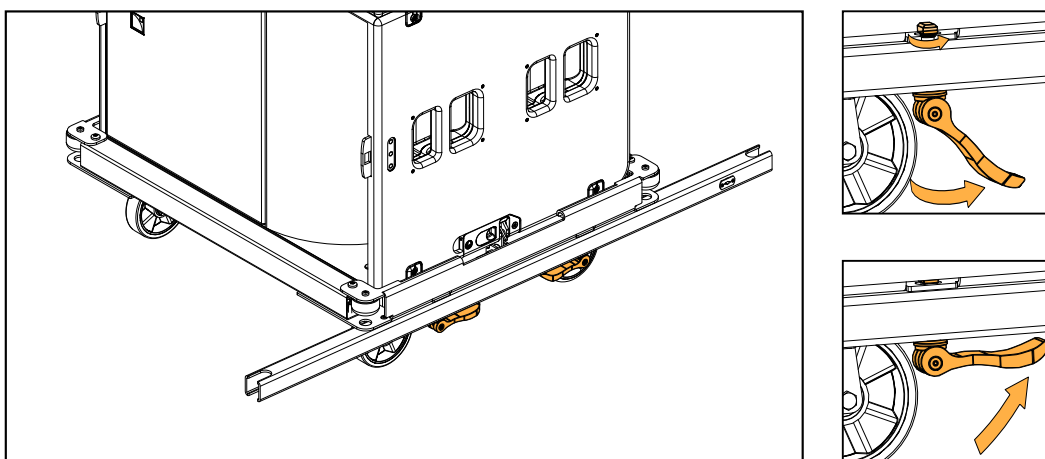

**2.** On each K2-JACK foot, rotate the wheel counter-clockwise until the central part is close to the base.

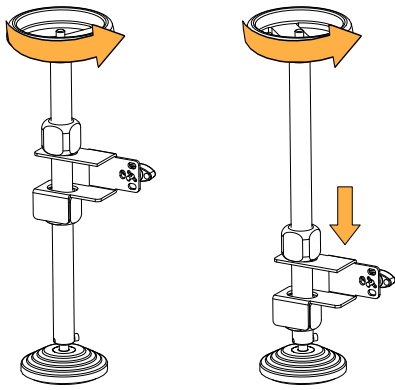

**3.** Attach the feet to the bar.

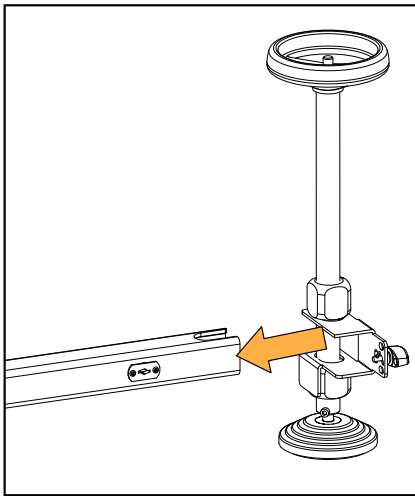

Insert the feet at both ends of the bar.

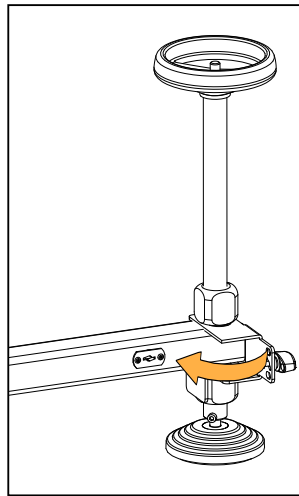

Pivot the central part so that it comes in contact with the bar.

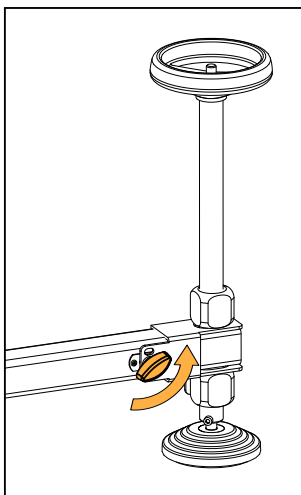

Lock the feet in position by giving a quarter-turn to the locking system.

4. Rotate the wheels clockwise to raise the array.

! Stop raising the stack as soon as the chariot wheels get off the ground.

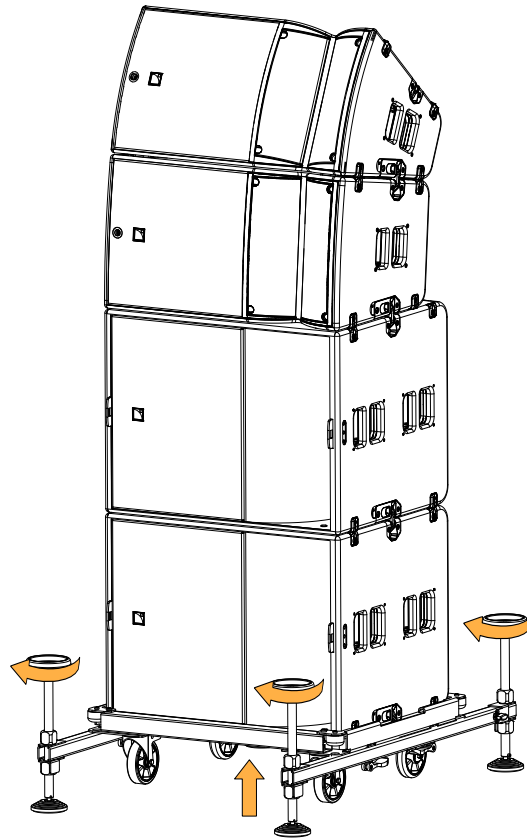

## Pole-mounting

### Pole-mounting A15 Wide/Focus

|                                |                                |
|--------------------------------|--------------------------------|
| <b>Type of deployment</b>      | pole-mount                     |
| <b>Rigging accessory</b>       | A-MOUNT<br>35 mm (1-3/8") pole |
| <b>Min number of operators</b> | 2                              |

**!** If the enclosure is to be mounted on KS21, refer to [KS21](#) (p.25) to select a compatible pole.

#### Realized site angles

| selected angle on A-MOUNT | realized site angle |           |
|---------------------------|---------------------|-----------|
|                           | A15 Wide            | A15 Focus |
| -15°                      | 0°                  | -10°      |
| -5°                       | 10°                 | 0°        |
| 0°                        | 15°                 | 5°        |

#### Assembly

##### Procedure

1. Place A-MOUNT on the enclosure, using the locating pins for positioning.  
Consider the final position of the enclosure.

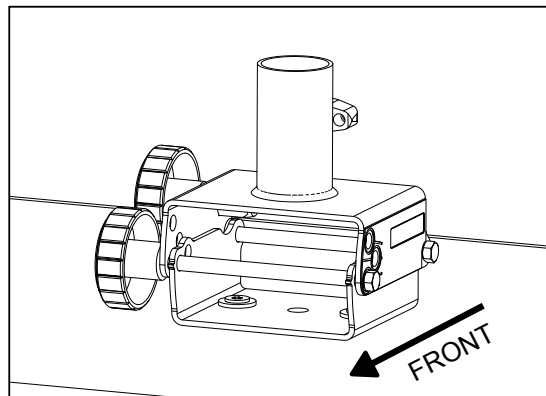
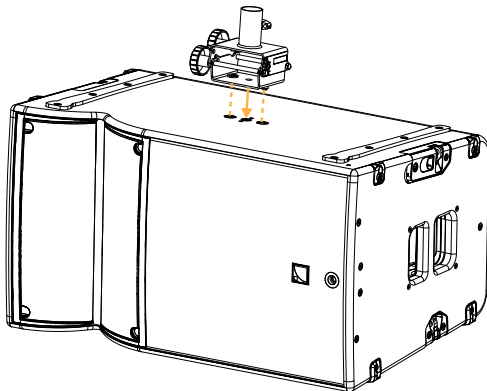

2. Remove the angle axis and secure A-MOUNT to the enclosure with the threaded knob.

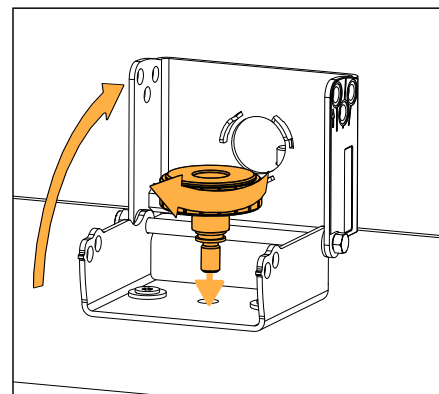
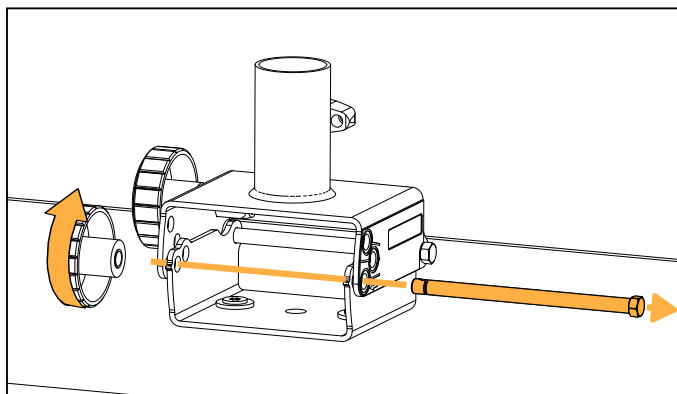

- 3.** Select the site angle and insert the axis in the corresponding hole.

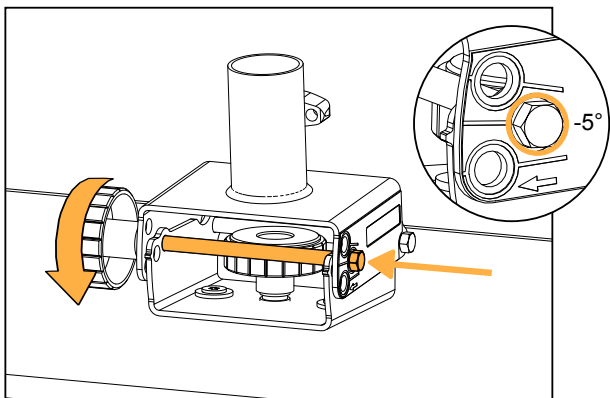

- 4.** Mount the assembly on a pole and tighten the wedge clamp by hand.

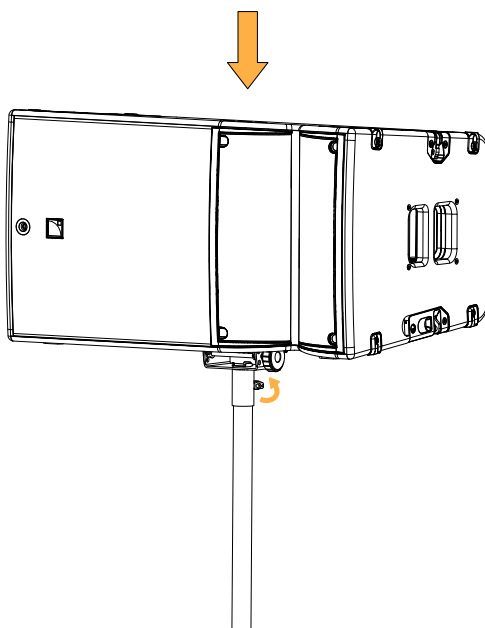

# Connection to LA amplified controllers

## Enclosure drive capacity per amplified controller

Make sure the total number of connected enclosures does not exceed the maximum number of enclosures per controller (refer to the footnotes).

|                | LA4X                            | LA8                             | LA12X                           |
|----------------|---------------------------------|---------------------------------|---------------------------------|
|                | per output <sup>*</sup> / total | per output <sup>*</sup> / total | per output <sup>*</sup> / total |
| A15 Wide/Focus | 1 / 4                           | 2 / 8                           | 3 / 12                          |
| KS21           | 1 / 4                           | 2 / 6 <sup>**</sup>             | 2 / 8                           |

## Cabling schemes for A15 Wide/Focus / KS21

Refer to the cabling schemes to connect the enclosures to different types of output connectors.

### One-channel speakON output

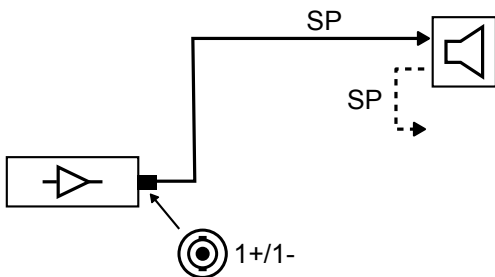

### Two-channel speakON output

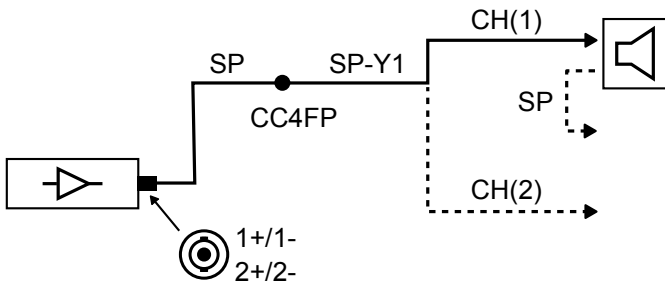

### Four-channel CA-COM output

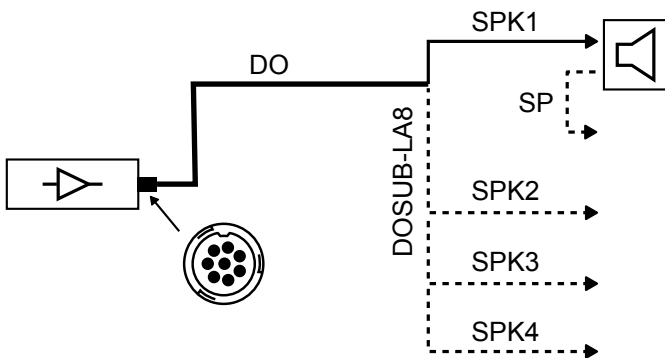

\* For passive loudspeakers, the value corresponds to the number of enclosures in parallel on the output. For active loudspeakers, the value corresponds to the number of sections in parallel on the output.

\*\* LA8 can drive up to two KS21 per output, but no more than six per controller at high level.



## Corrective maintenance

### Tools and consumables

---

Before performing maintenance on this product, make sure all the tools listed are available. References are given for FACOM® products in this table. Other manufacturers can be used.

| <b>name</b>                       | <b>reference</b>     | <b>distributor</b> |
|-----------------------------------|----------------------|--------------------|
| set of 6-point 1/4" sockets *     | RL.NANO1 / R.360NANO | FACOM              |
| torque screwdriver (2 - 10 N.m) * | A.404                | FACOM              |
| flat plastic tool                 | -                    | -                  |
| double face adhesive tape         | -                    | -                  |
| compressed air blower             | -                    | -                  |



\* included in the L-Acoustics Maintenance Toolcase.

### Maintenance Toolcase

The Maintenance Toolcase is a carry-on suitcase that includes all the tools required to perform maintenance on L-Acoustics products. This toolcase is aimed at Certified Providers.

The Maintenance Toolcase uses a Peli™ 1510 Protector case that features three pre-cut layers of foam to safely fit the tools. The Maintenance Toolcase includes tools manufactured by FACOM®, Fluke®, Tohnichi, ABUS, and Würth.



All third-party trademarks, registered trademarks, or product names are the property of their respective owners.

## A15 Focus

### Introduction

This section contains the following maintenance procedures:

- [D/R - Grill](#) (p.109)
- [D/R - Fin](#) (p.110)
- [D/R - LF speaker](#) (p.111)
- [D/R - Connector plate](#) (p.112)
- [D/R - HF driver](#) (p.113)
- [D/R - HF diaphragm](#) (p.114)

For advanced maintenance, contact your L-Acoustics representative.

### Exploded view

In order to operate, follow the order outlined here. Each assembly refers to the corresponding Disassembly/Reassembly (D/R) procedure and the necessary repair kit.

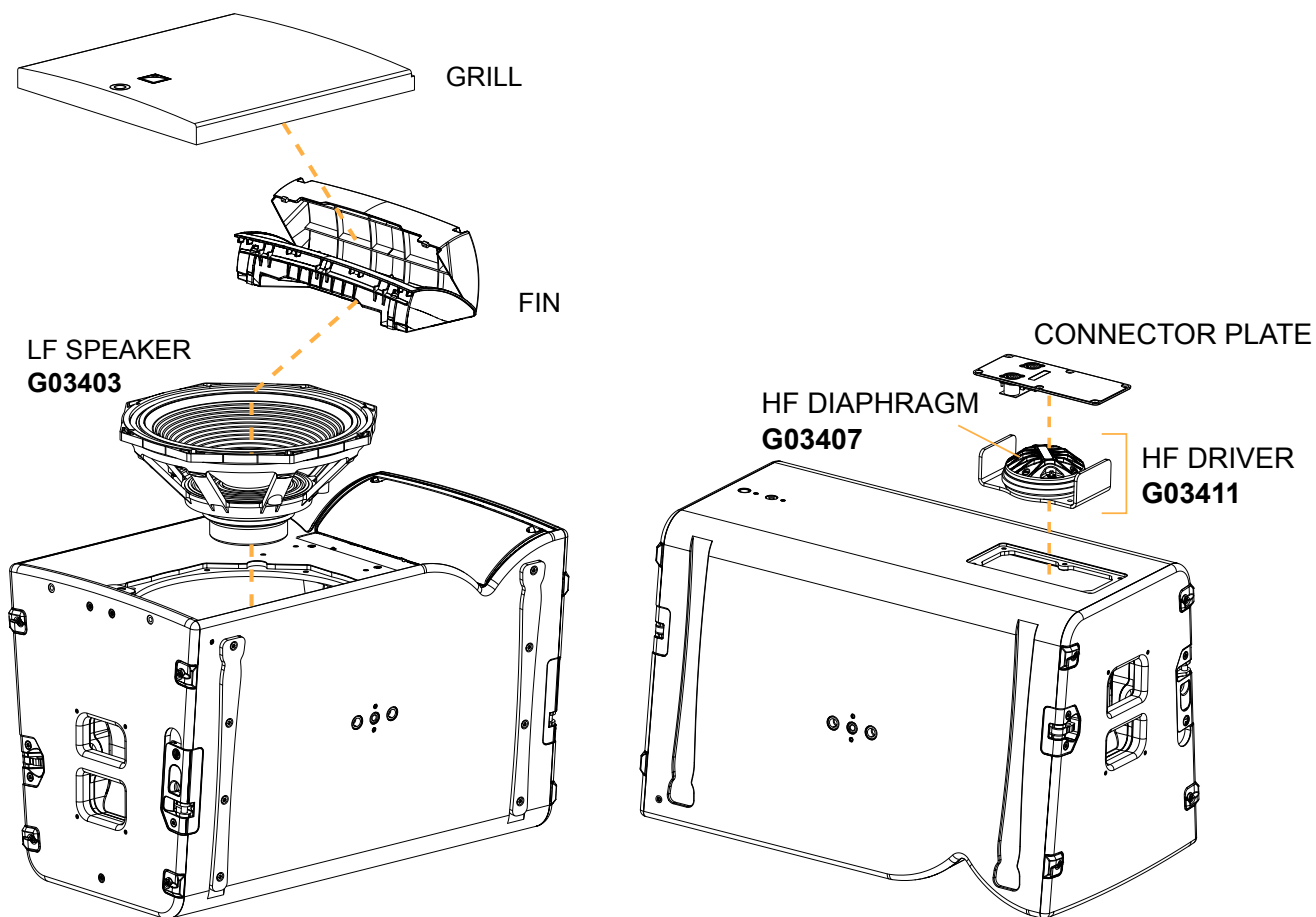

## Disassembly and Reassembly procedures

### D/R - Grill

#### Tools

- torque screwdriver
- T30 Torx bit
- flat plastic tool

#### Repair kit

#### G03403

KR loudspeaker 15" A15FOCUS/WIDE

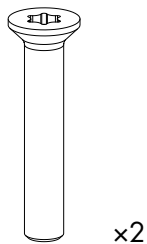

S221

M6x35 Torx

#### Exploded view

**!** For safety reasons, always use the new screws and spare parts provided in the KR.  
If no new screws are available, use blue threadlocker.

Use a flat plastic tool as a lever.

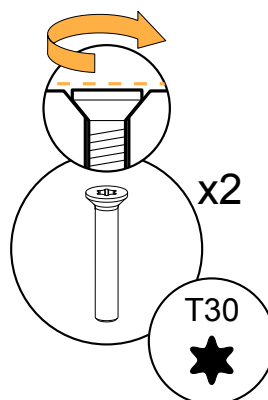
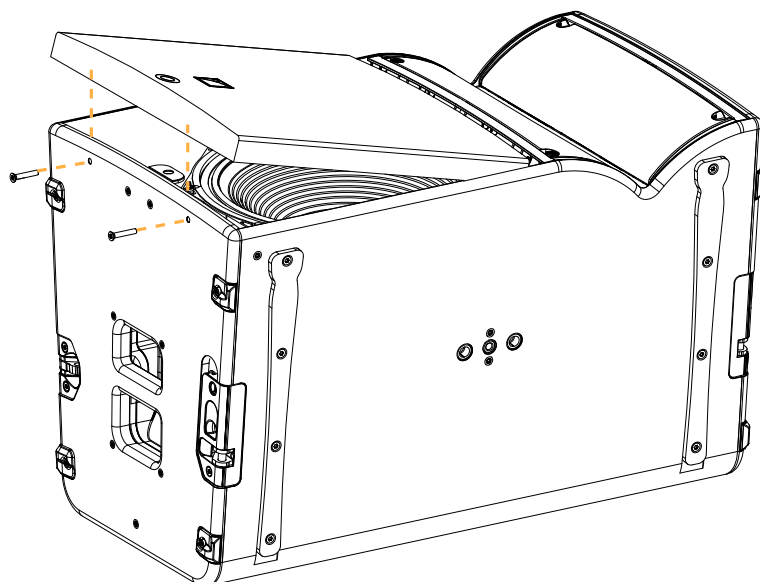

## D/R - Fin

### Tools

- torque screwdriver
- screwdriver extension
- T30 Torx bit
- flat plastic tool

### Repair kit

#### G03403

KR loudspeaker 15" A15FOCUS/WIDE

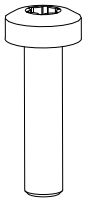

x5

S100143

M6x25 Torx

### Prerequisite

Grill removed.

See [D/R - Grill](#) (p.109).

### Exploded view

 For safety reasons, always use the new screws and spare parts provided in the KR.  
If no new screws are available, use blue threadlocker.

 Use a flat tool made of **smooth plastic** to avoid scratching the fins.

With the flat plastic tool, unhook the fin clips one by one.

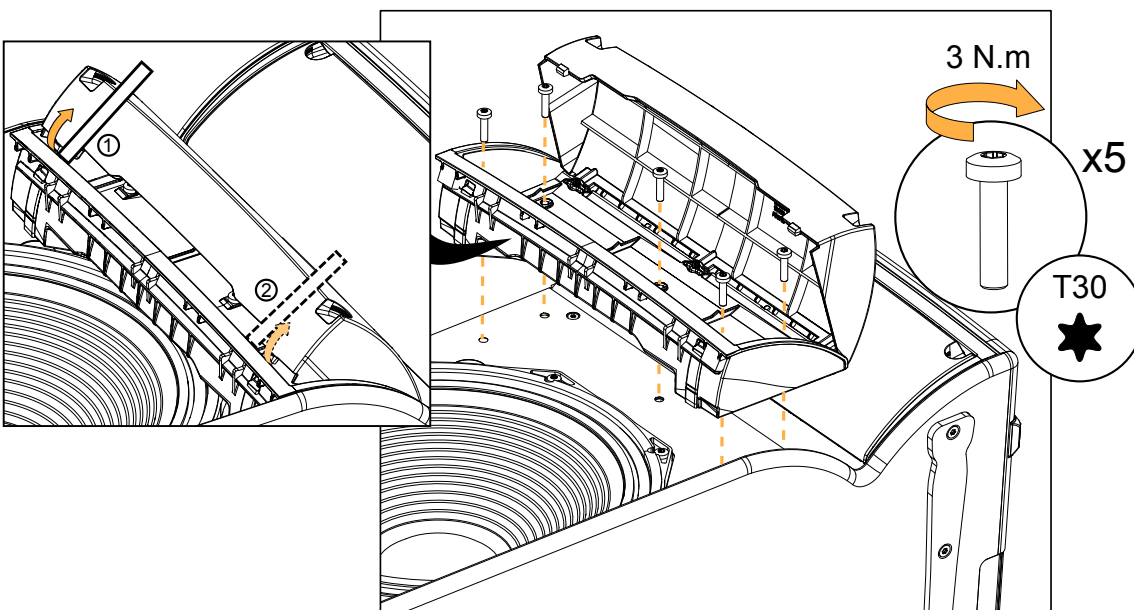

## D/R - LF speaker

### Tools

- torque screwdriver
- T30 Torx bit

### Repair kit

#### G03403

KR loudspeaker 15" A15FOCUS/WIDE

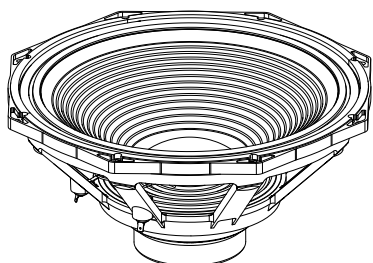

x1

17873

15" LF speaker - 8 Ω (with gasket)

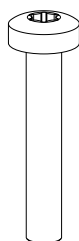

x8

S247

M6x35 Torx

### Prerequisite

Grill removed.

Left-hand side fin removed.

See [D/R - Grill](#) (p.109).

See [D/R - Fin](#) (p.110).

### Exploded view



For safety reasons, always use the new screws and spare parts provided in the KR.

If no new screws are available, use blue threadlocker.

Position the connectors toward the mark on the cabinet.

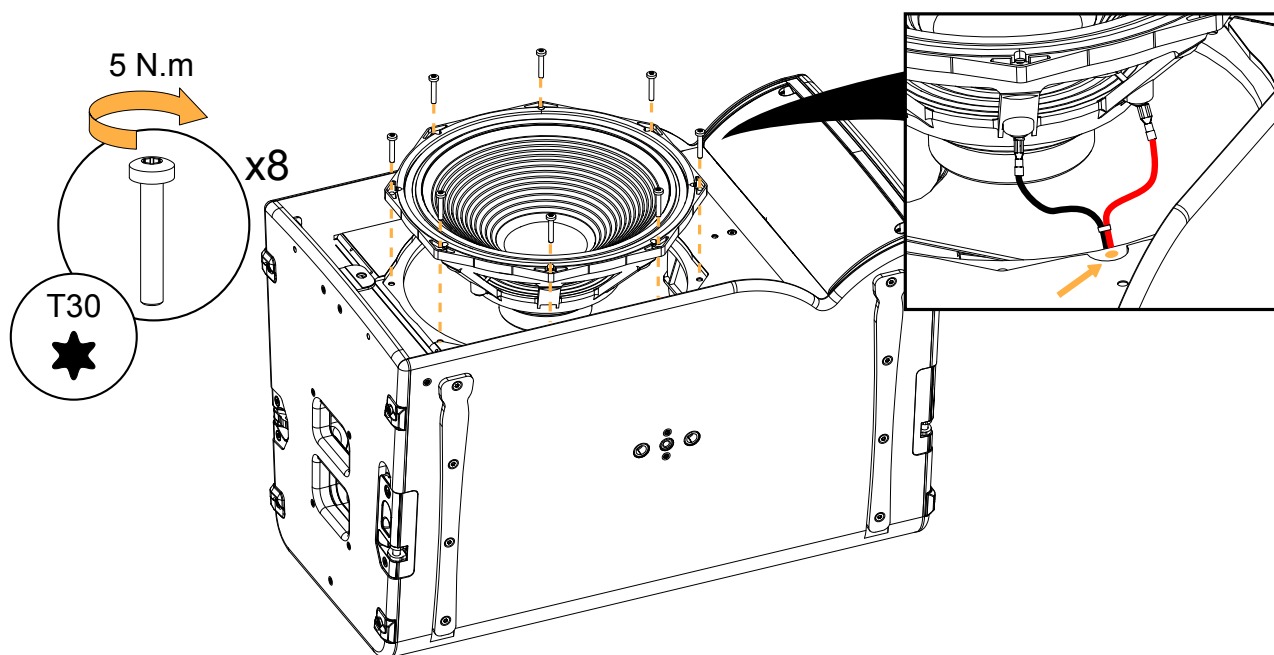

### What to do next

Perform the [Acoustical check](#) (p.71) procedures.

## D/R - Connector plate

### Tools

- torque screwdriver
- T25 Torx bit
- flat plastic tool

### Repair kits

**G03411 - KR compression driver A15FOCUS/WIDE or  
G03407 - KR diaphragm A15FOCUS/WIDE**

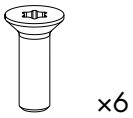

S100086

M5x16 Torx

### Exploded view

- ❗ For safety reasons, always use the new screws and spare parts provided in the KR. If no new screws are available, use blue threadlocker.
- ❗ Gradually tighten the screws following a star pattern.

Use a flat plastic tool as a lever to remove the connector plate.

Position the connector plate with the connectors towards the middle of the enclosure.

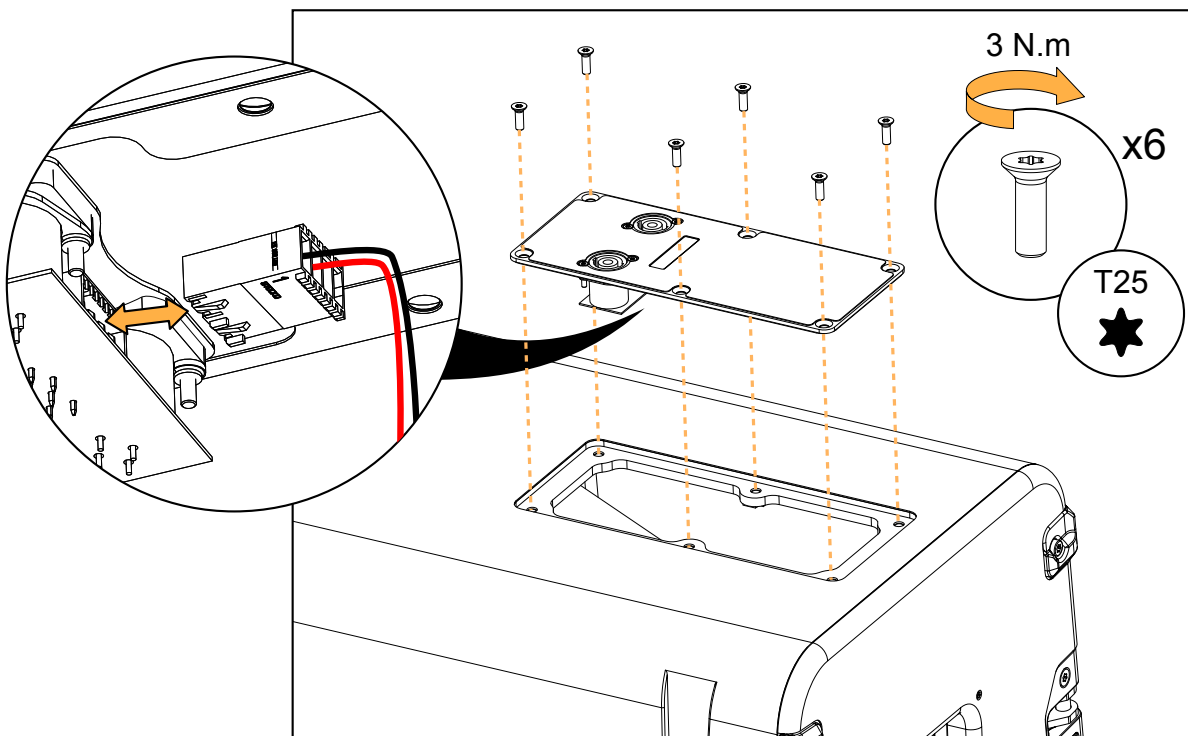

**D/R - HF driver****Tools**

- torque screwdriver
- screwdriver extension
- T30 Torx bit

**Repair kit****G03411 \***

KR compression driver A15FOCUS/WIDE

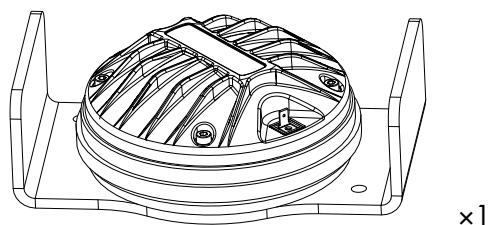

x1

G100245

3" HF driver assembly - 8 Ω

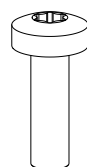

x2

S100094

M6x20 Torx



\* The screws and fasteners are also provided in the G03407 (KR diaphragm A15FOCUS/WIDE).

**Prerequisite**

Connector plate removed.

See [D/R - Connector plate](#) (p.112).**Exploded view**

For safety reasons, always use the new screws and spare parts provided in the KR.  
If no new screws are available, use blue threadlocker.

Carefully disconnect the cables before removing the driver assembly.

Use the positive (red) connector as a reference point to position the driver assembly.

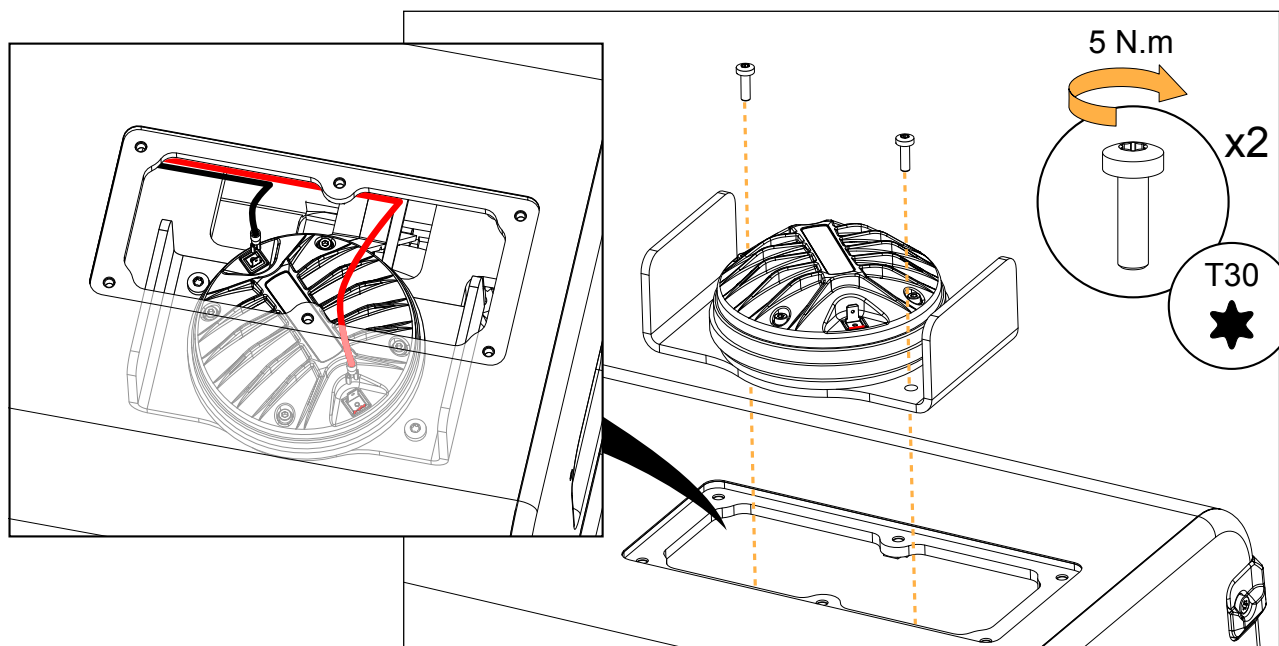

## D/R - HF diaphragm

### Tools

- torque screwdriver
- T20 Torx bit
- 3 mm hex bit
- compressed air blower

### Consumables

- double face adhesive tape

### Repair kit

#### G03407

KR diaphragm A15FOCUS/WIDE

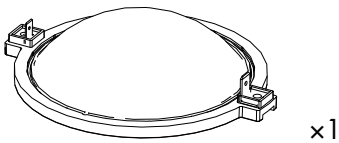

17581

diaphragm assembly (with 2 shims)

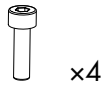

S100082

M4x14 hex

### Prerequisite

Connector plate removed.

HF driver removed from the cabinet.

The driver is placed on a flat surface in a dust-free environment.

See [D/R - Connector plate](#) (p.112).

See [D/R - HF driver](#) (p.113).

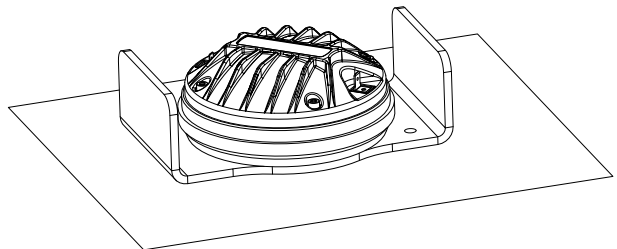

### Disassembly

#### Procedure

1. Remove the four screws securing the cover.  
Use the T20 Torx bit.
2. Remove the cover.
3. Carefully remove the diaphragm.
4. If there are shims on the dome, carefully remove them.  
Take note of how many and what kind of shims are present.



## Reassembly

### About this task



For safety reasons, always use the new screws and spare parts provided in the KR.

### Procedure

1. Clean the dome and the air gap.



**Make sure the air gap is perfectly clean before reassembly.**

Use a blower or double face adhesive to remove any particle.

2. Place the same kind and number of shims that were initially present.
3. Carefully place the diaphragm, using the positive (red) connector as reference point.
4. Position the cover and turn it to align it with the screw holes.



Gradually tighten the screws following a star pattern.

5. Secure the cover using four S100082 screws.  
Use the 3 mm hex bit. Set the torque to 3 N.m.

### What to do next

Perform the [Acoustical check](#) (p.71) procedures.

## A15 Wide

### Introduction

This section contains the following maintenance procedures:

- [D/R - Grill](#) (p.117)
- [D/R - Fin](#) (p.118)
- [D/R - LF speaker](#) (p.119)
- [D/R - Connector plate](#) (p.120)
- [D/R - HF driver](#) (p.121)
- [D/R - HF diaphragm](#) (p.122)

For advanced maintenance, contact your L-Acoustics representative.

### Exploded view

In order to operate, follow the order outlined here. Each assembly refers to the corresponding Disassembly/Reassembly (D/R) procedure and the necessary repair kit.

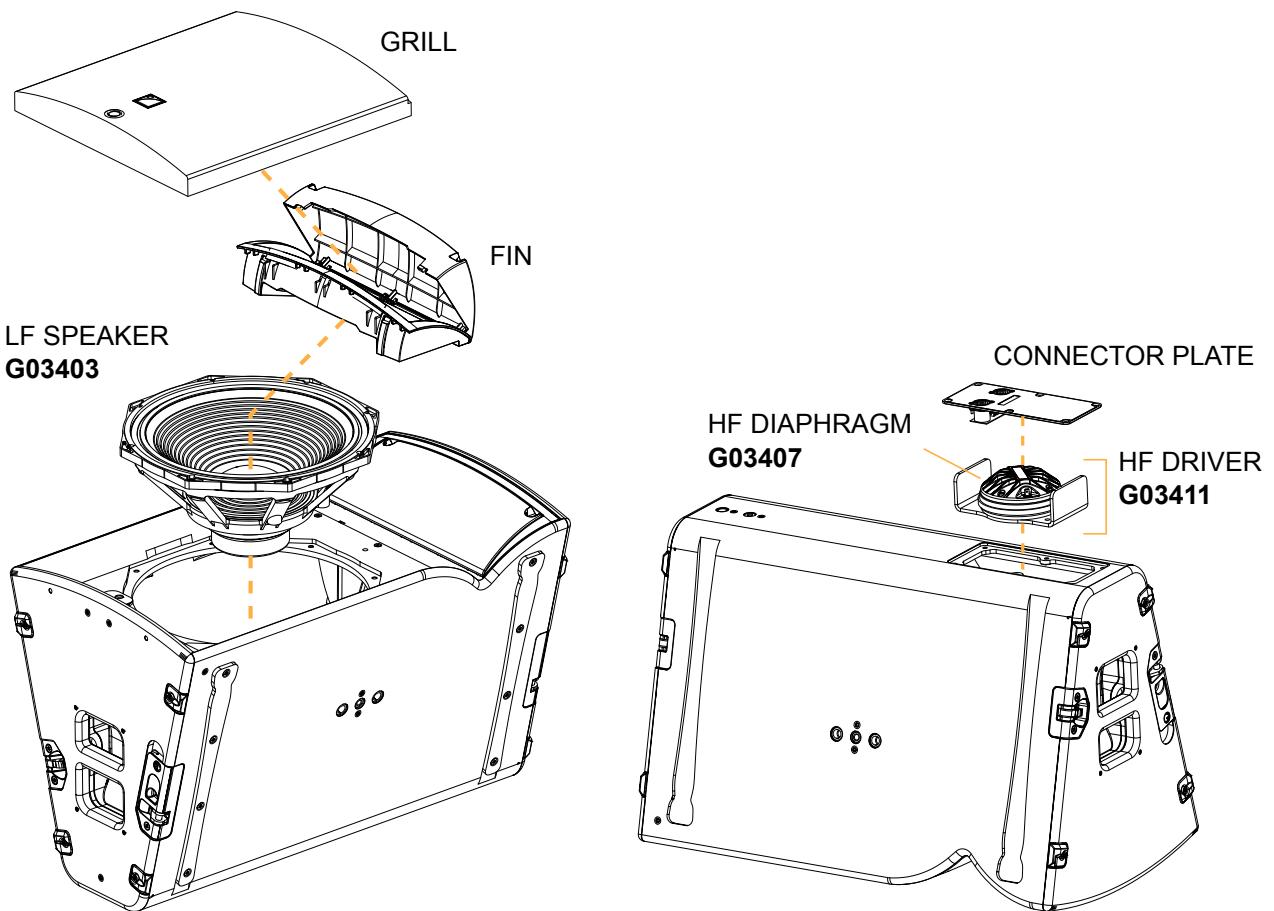

## Disassembly and Reassembly procedures

### D/R - Grill

#### Tools

- torque screwdriver
- T30 Torx bit
- flat plastic tool

#### Repair kit

#### G03403

KR loudspeaker 15" A15FOCUS/WIDE

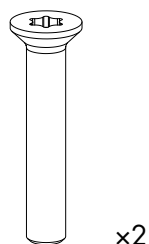

S221

M6x35 Torx

#### Exploded view



For safety reasons, always use the new screws and spare parts provided in the KR.  
If no new screws are available, use blue threadlocker.

Use a flat plastic tool as a lever.

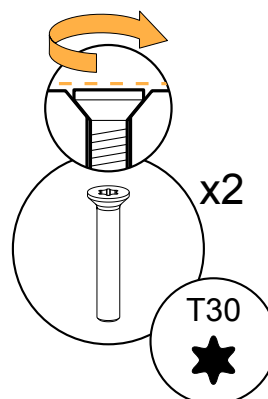
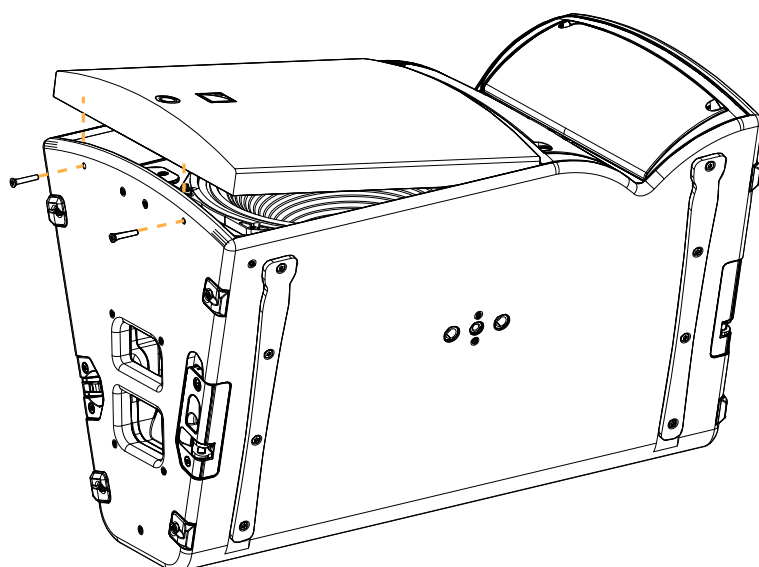

## D/R - Fin

### Tools

- torque screwdriver
- screwdriver extension
- T30 Torx bit
- flat plastic tool

### Repair kit

#### G03403

KR loudspeaker 15" A15FOCUS/WIDE

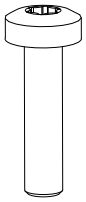

x5

S100143

M6x25 Torx

### Prerequisite

Grill removed.

See [D/R - Grill](#) (p.117).

### Exploded view



For safety reasons, always use the new screws and spare parts provided in the KR.  
If no new screws are available, use blue threadlocker.



Use a flat tool made of **smooth plastic** to avoid scratching the fins.

With the flat plastic tool, unhook the fin clips one by one.

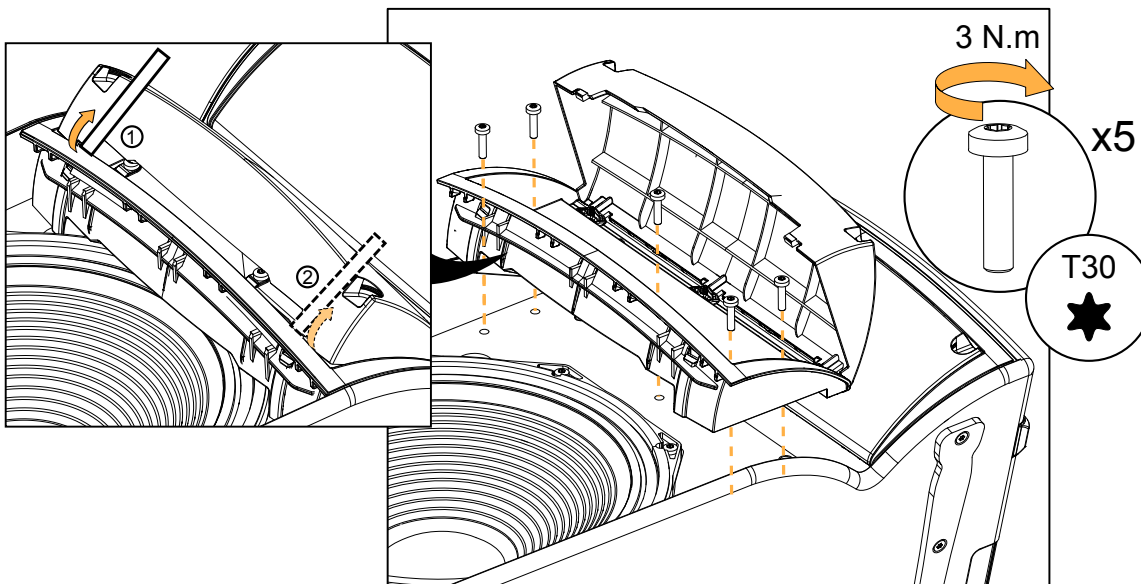

## D/R - LF speaker

### Tools

- torque screwdriver
- T30 Torx bit

### Repair kit

#### G03403

KR loudspeaker 15" A15FOCUS/WIDE

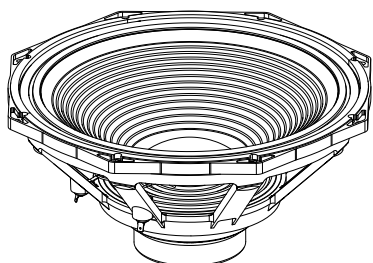

x1

17873

15" LF speaker - 8 Ω (with gasket)

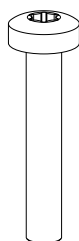

x8

S247

M6x35 Torx

### Prerequisite

Grill removed.

Left-hand side fin removed.

See [D/R - Grill](#) (p.117).

See [D/R - Fin](#) (p.118).

### Exploded view



For safety reasons, always use the new screws and spare parts provided in the KR.

If no new screws are available, use blue threadlocker.

Position the connectors toward the mark on the cabinet.

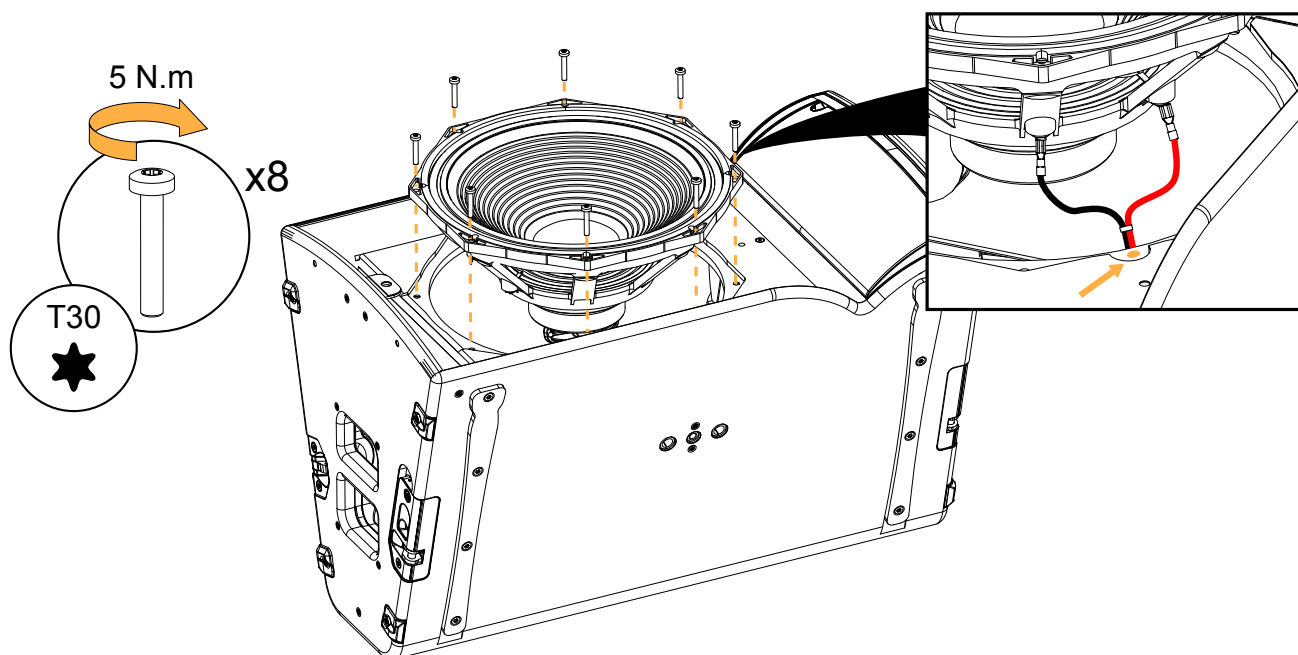

### What to do next

Perform the [Acoustical check](#) (p.71) procedures.

## D/R - Connector plate

### Tools

- torque screwdriver
- T25 Torx bit
- flat plastic tool

### Repair kits

**G03411 - KR compression driver A15FOCUS/WIDE or  
G03407 - KR diaphragm A15FOCUS/WIDE**

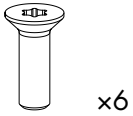

S100086

M5x16 Torx

### Exploded view

- ! For safety reasons, always use the new screws and spare parts provided in the KR.  
If no new screws are available, use blue threadlocker.
- ! Gradually tighten the screws following a star pattern.

Use a flat plastic tool as a lever to remove the connector plate.

Position the connector plate with the connectors towards the middle of the enclosure.

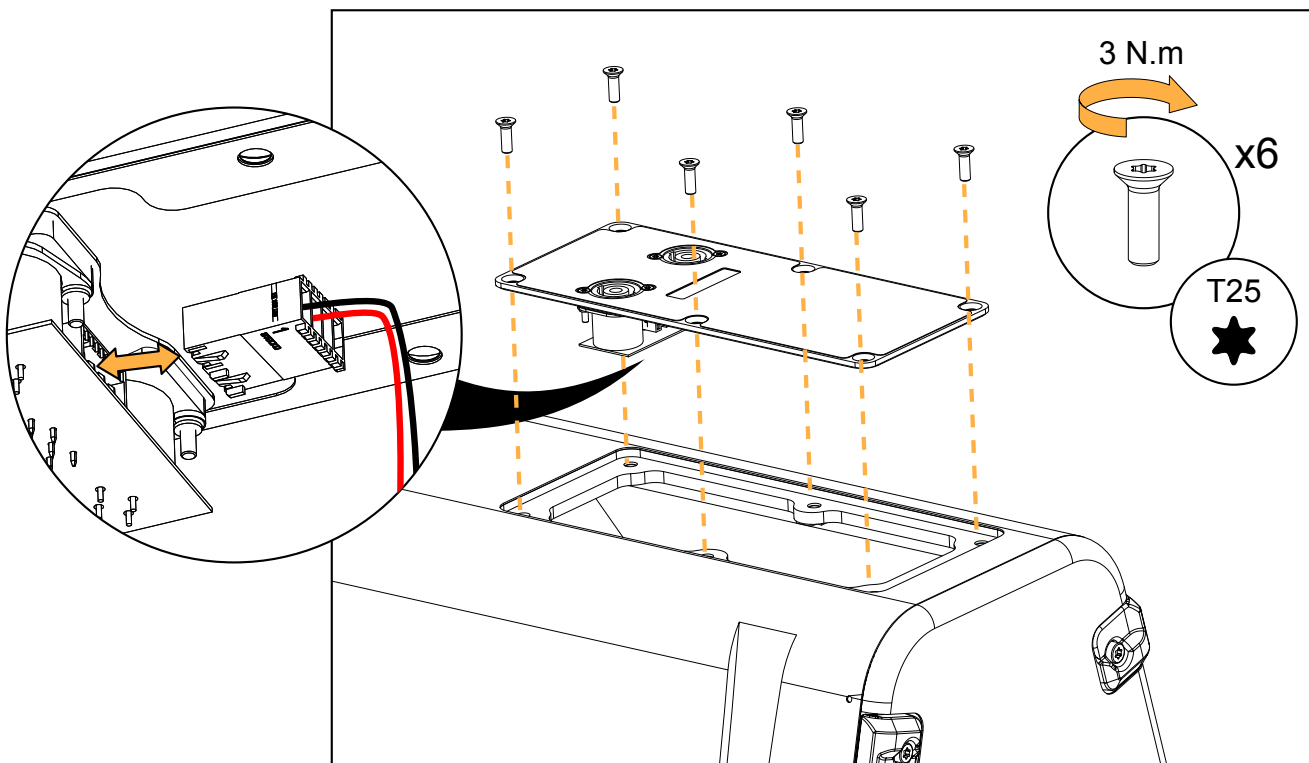

**D/R - HF driver****Tools**

- torque screwdriver
- screwdriver extension
- T30 Torx bit

**Repair kit****G03411 \***

KR compression driver A15FOCUS/WIDE

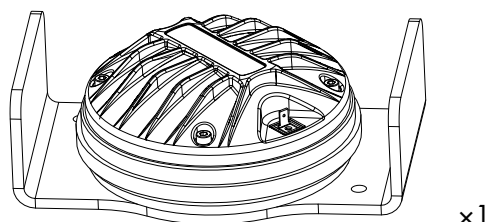

G100245

3" HF driver assembly - 8 Ω

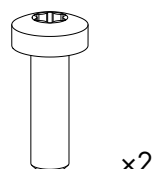

S100094

M6x20 Torx



\* The screws and fasteners are also provided in the G03407 (KR diaphragm A15FOCUS/WIDE).

**Prerequisite**

Connector plate removed.

See [D/R - Connector plate](#) (p.120).**Exploded view**

For safety reasons, always use the new screws and spare parts provided in the KR.  
If no new screws are available, use blue threadlocker.

Carefully disconnect the cables before removing the driver assembly.

Use the positive (red) connector as a reference point to position the driver assembly.

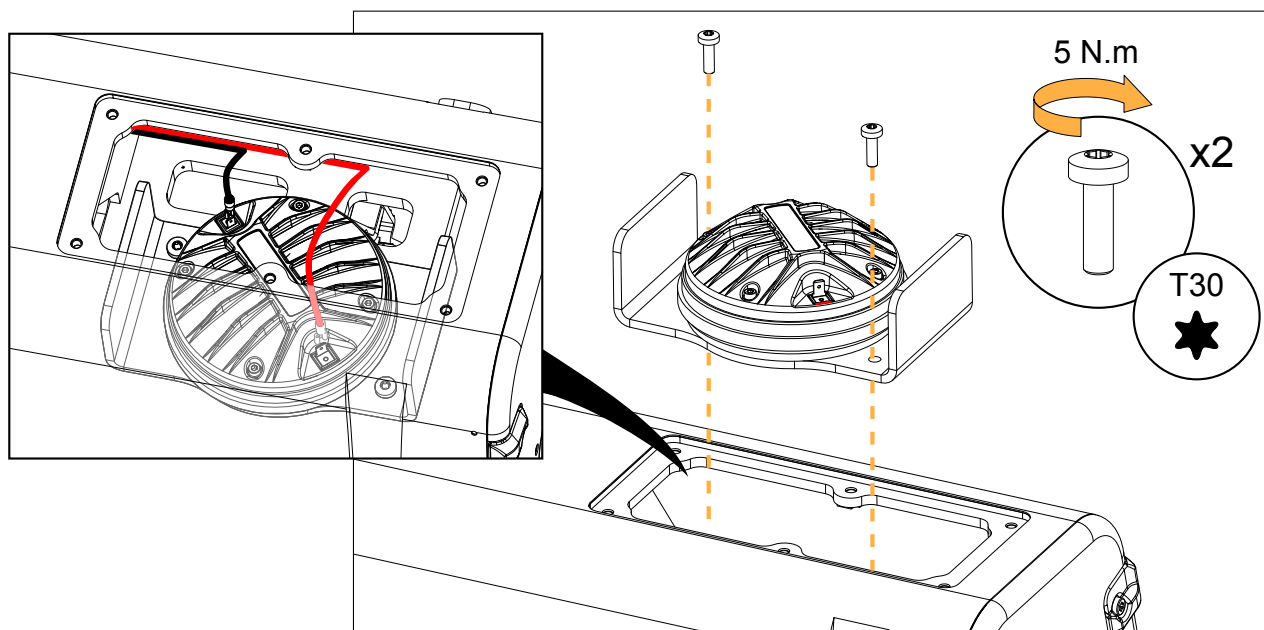

## D/R - HF diaphragm

### Tools

- torque screwdriver
- T20 Torx bit
- 3 mm hex bit
- compressed air blower

### Consumables

- double face adhesive tape

### Repair kit

#### G03407

KR diaphragm A15FOCUS/WIDE

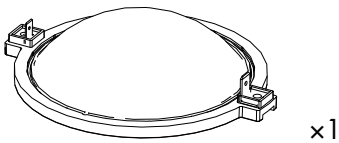

17581

diaphragm assembly (with 2 shims)

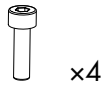

S100082

M4x14 hex

### Prerequisite

Connector plate removed.

HF driver removed from the cabinet.

The driver is placed on a flat surface in a dust-free environment.

See [D/R - Connector plate](#) (p.120).

See [D/R - HF driver](#) (p.121).

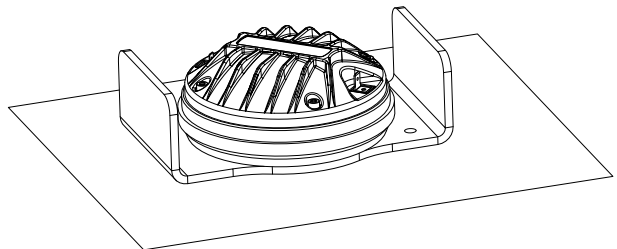

### Disassembly

#### Procedure

1. Remove the four screws securing the cover.  
Use the T20 Torx bit.
2. Remove the cover.
3. Carefully remove the diaphragm.
4. If there are shims on the dome, carefully remove them.  
Take note of how many and what kind of shims are present.



## Reassembly

### About this task



For safety reasons, always use the new screws and spare parts provided in the KR.

### Procedure

1. Clean the dome and the air gap.



**Make sure the air gap is perfectly clean before reassembly.**

Use a blower or double face adhesive to remove any particle.

2. Place the same kind and number of shims that were initially present.
3. Carefully place the diaphragm, using the positive (red) connector as reference point.
4. Position the cover and turn it to align it with the screw holes.



Gradually tighten the screws following a star pattern.

5. Secure the cover using four S100082 screws.  
Use the 3 mm hex bit. Set the torque to 3 N.m.

### What to do next

Perform the [Acoustical check](#) (p.71) procedures.

## **KS21**

---

## Introduction

This section contains the following maintenance procedures:

- [D/R - Grill](#) (p.126)
- [D/R - Fixing bars](#) (p.127)
- [D/R - LF speaker](#) (p.128)

For advanced maintenance, contact your L-Acoustics representative.

## Exploded view

In order to operate, follow the order outlined here. Each assembly refers to the corresponding Disassembly/Reassembly (D/R) procedure and the necessary repair kit.

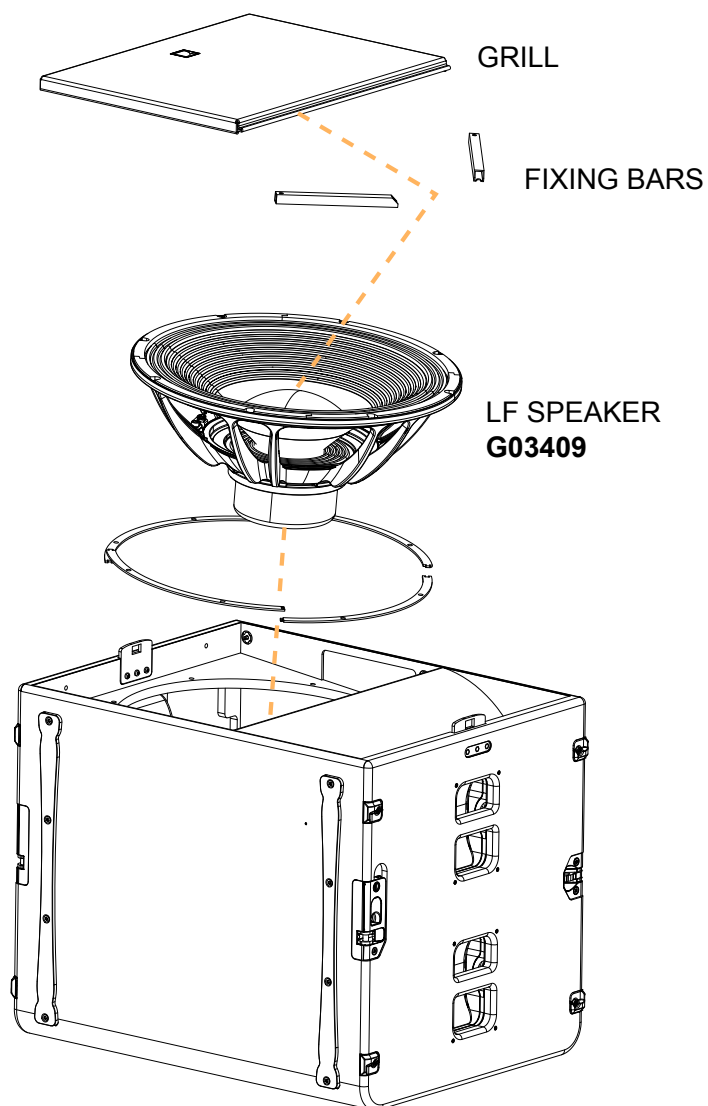

## Disassembly and Reassembly procedures

### D/R - Grill

#### Tools

- torque screwdriver
- T30 Torx bit

#### Repair kit

### G03409

KR loudspeaker 21" KS21

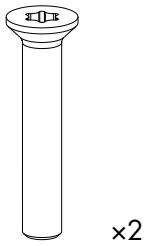

S221

M6x35 Torx

#### Exploded view



For safety reasons, always use the new screws and spare parts provided in the KR.  
If no new screws are available, use blue threadlocker.

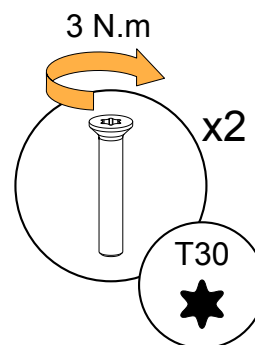
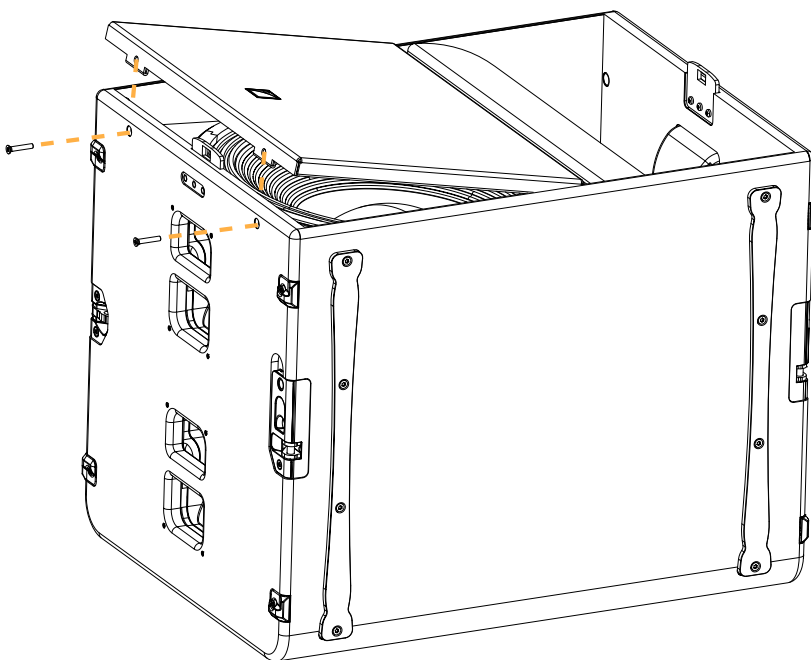

## D/R - Fixing bars

### Tools

- torque screwdriver
- T30 Torx bit

### Repair kit

#### G03409

KR loudspeaker 21" KS21

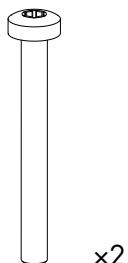

S253

M6 x 55 Torx

### Prerequisite

Grill removed.

See [D/R - Grill](#) (p.126).

### Exploded view



For safety reasons, always use the new screws and spare parts provided in the KR.

If no new screws are available, use blue threadlocker.

For reassembly, slide the fixing bars under the vent panel to attach them to the studs, then secure them with the screws.

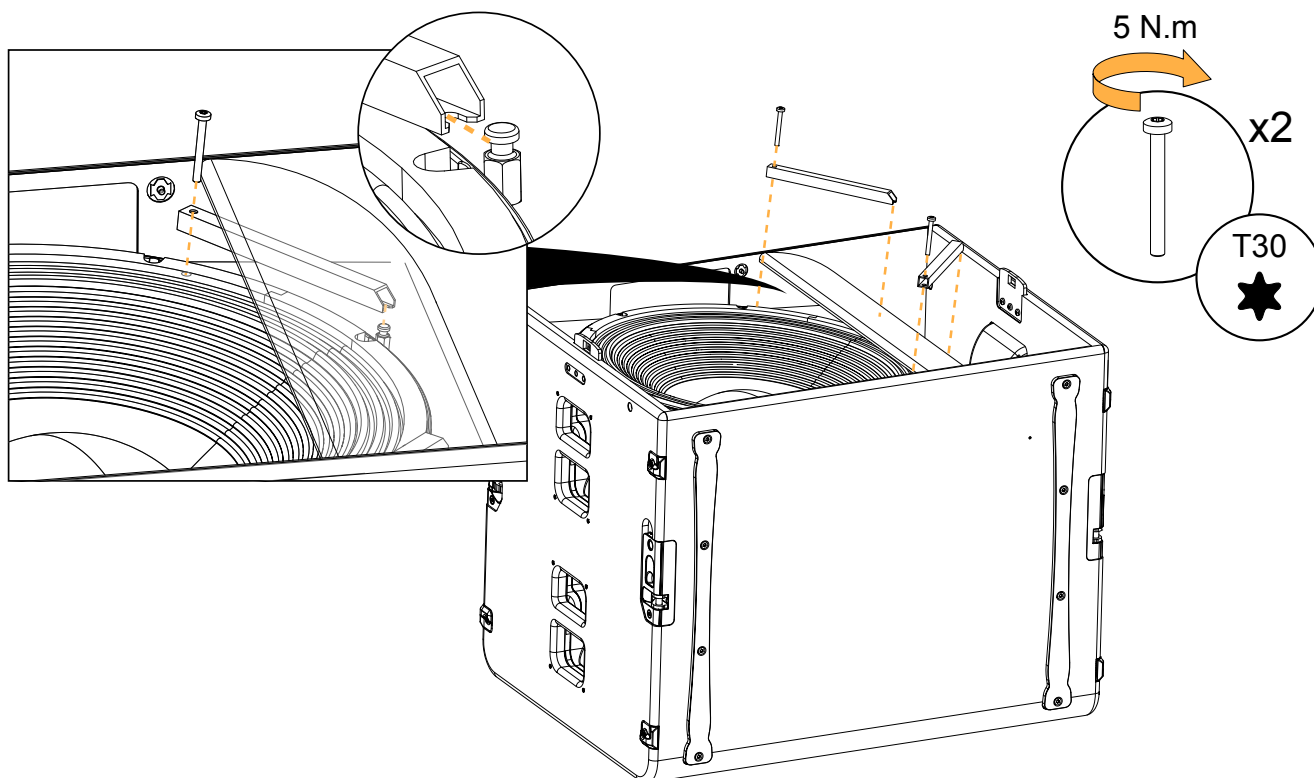

## D/R - LF speaker

### Tools

- torque screwdriver
- T30 Torx bit

### Repair kit

#### G03409

KR loudspeaker 21" KS21

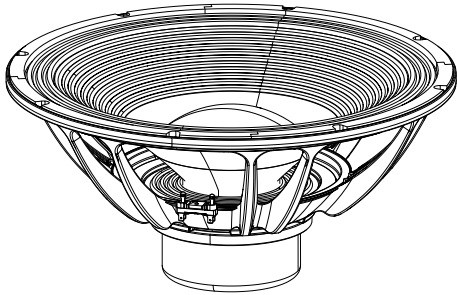

x1

17945

21" LF speaker - 8 Ω

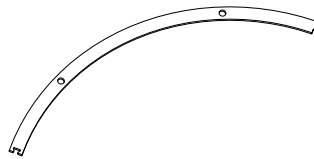

x4

102157

21" speaker gasket



x6

S247

M6x35 Torx

### Prerequisite

Grill removed.

See [D/R - Grill](#) (p.126).

### Exploded views



For safety reasons, always use the new screws and spare parts provided in the KR. If no new screws are available, use blue threadlocker.



Gradually tighten the screws following a star pattern.

Tilt the speaker to remove it from the cabinet. Carefully disconnect the cables.

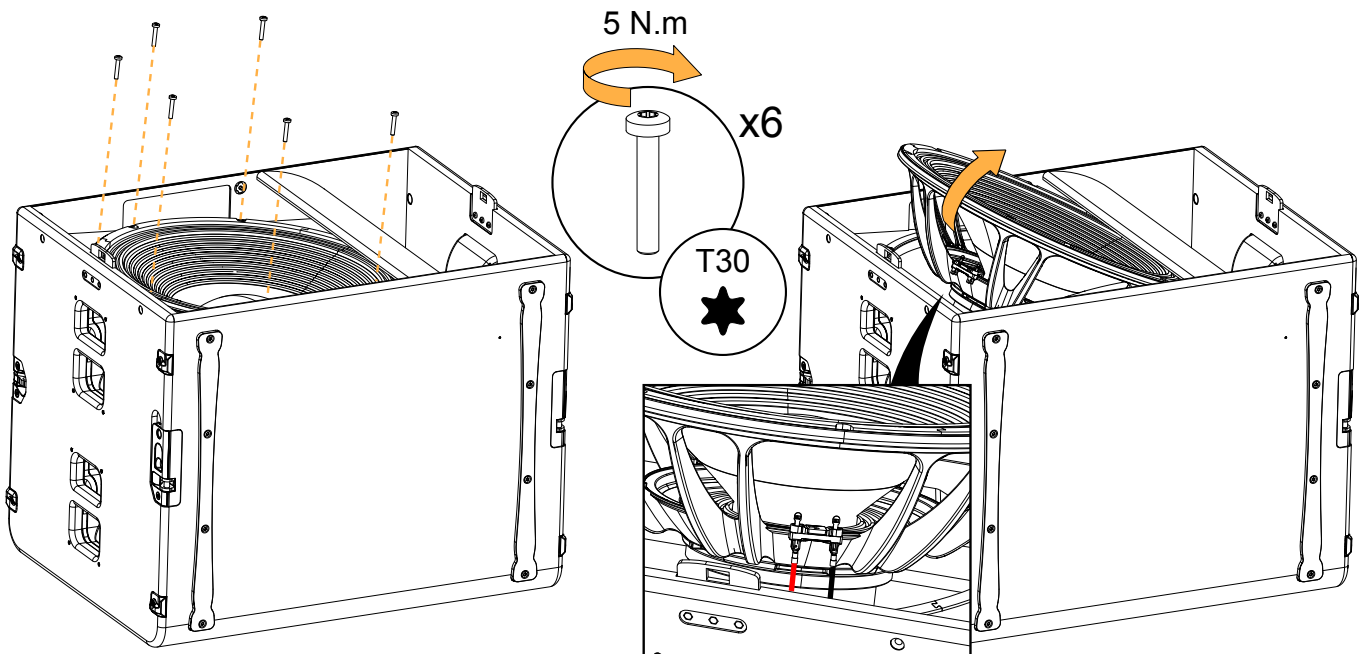

**i** If the speaker gasket is damaged, remove and replace it.

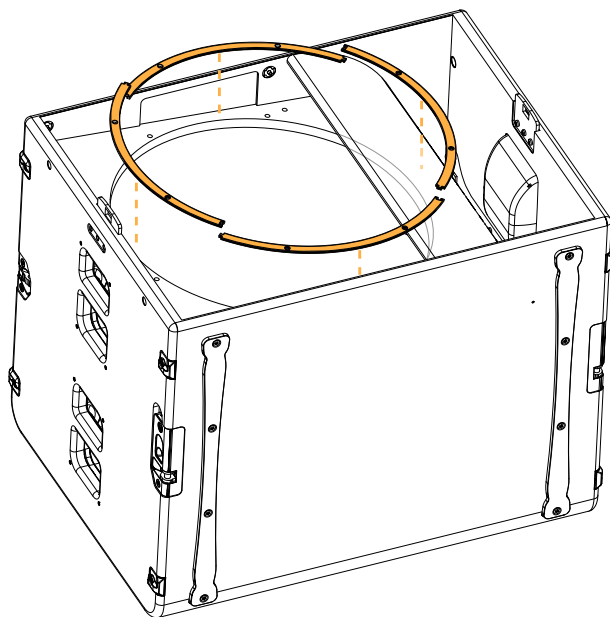

## D/R - Ground runners

### Tools

- torque screwdriver
- T30 Torx bit

### Repair kit

#### G03414

#### KR ground runners KS21

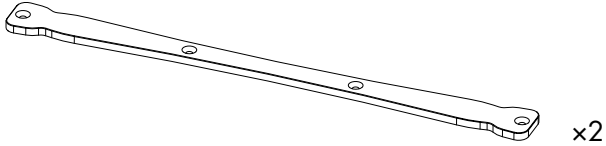

101438

ground runner

#### G03413

#### KR screws and fasteners KS21

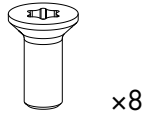

S100041

M6x16 Torx

### Exploded view



For safety reasons, always use the new screws and spare parts provided in the KR.  
If no new screws are available, use blue threadlocker.

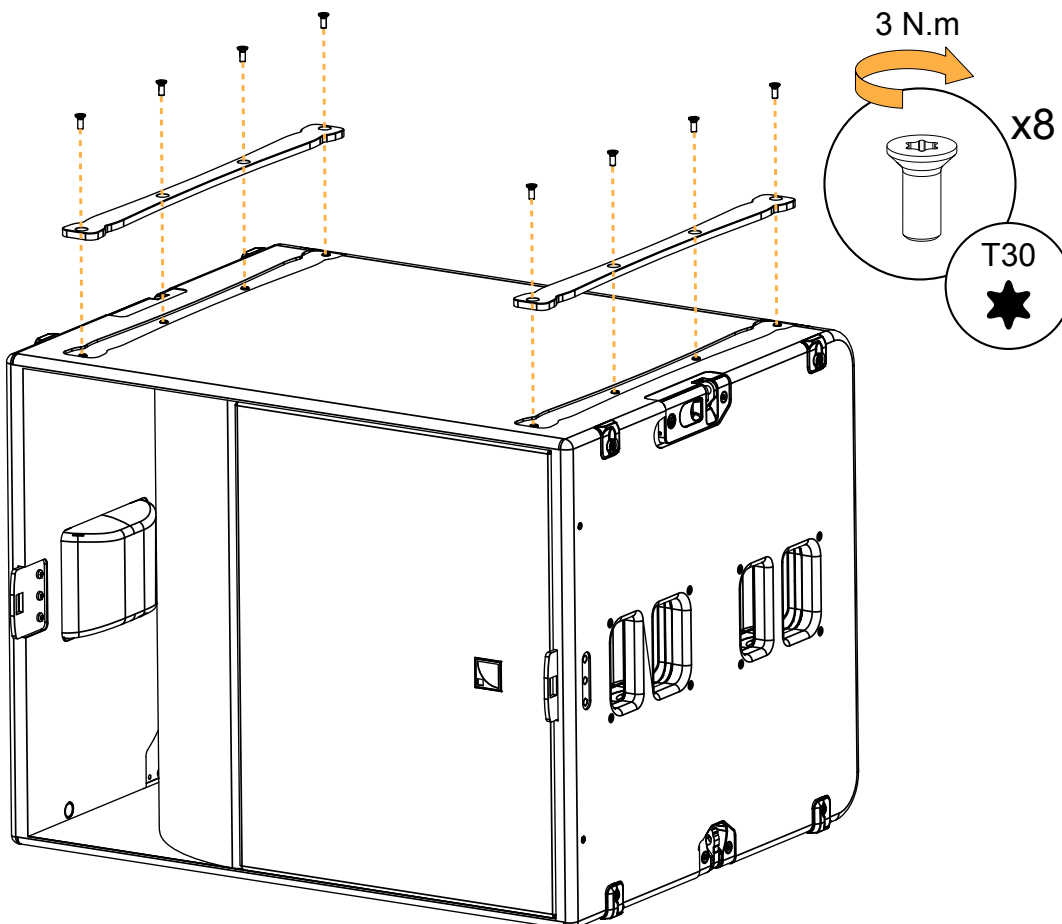



**D/R - Corner stops****Tools**

- torque screwdriver
- T30 Torx bit

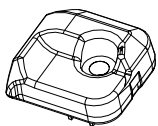
**Repair kit****G03439****KR corner stops A10 / A15 / KS21**

x8

101611

corner stop

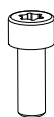
**G03413****KR screws and fasteners KS21**

x8

S100181

M6x16 Torx

**Exploded view**

For safety reasons, always use the new screws and spare parts provided in the KR.  
If no new screws are available, use blue threadlocker.

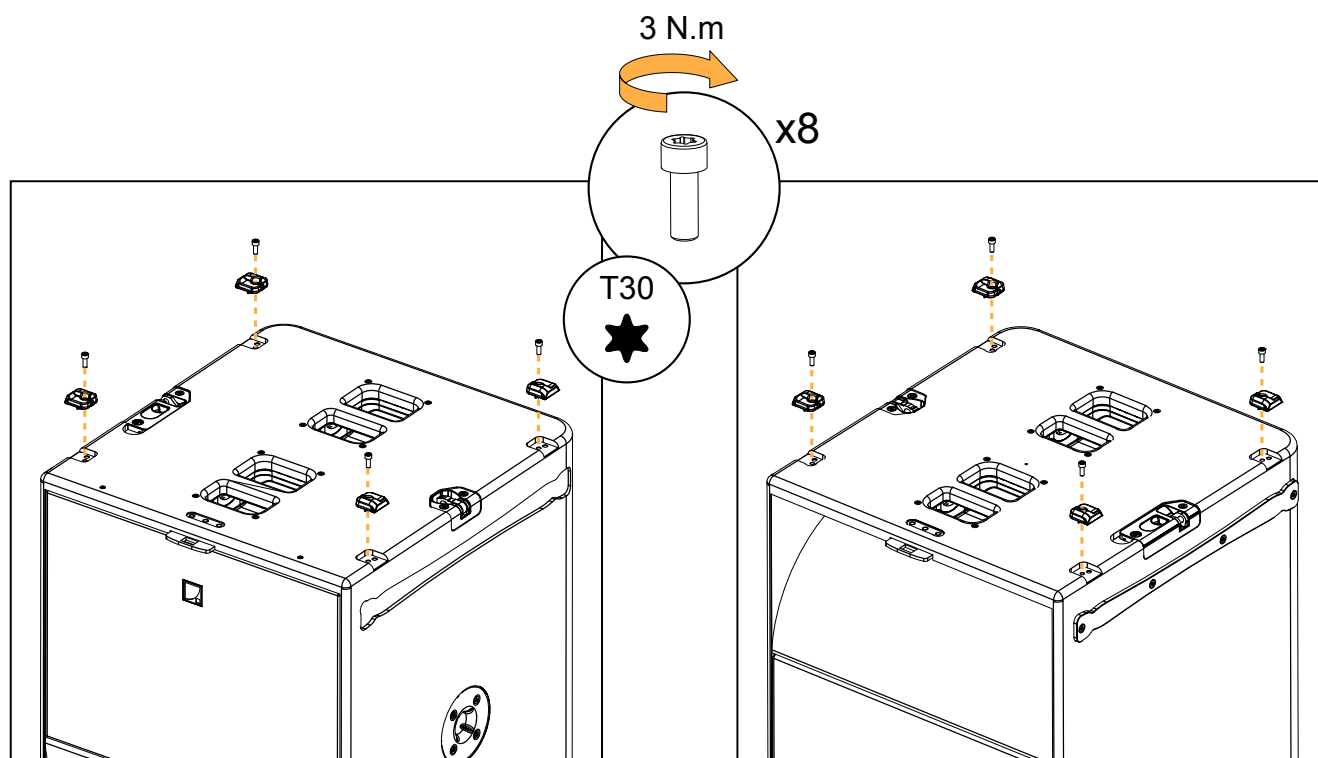

## D/R - Pole-mount

### Tools

- torque screwdriver
- T30 Torx bit

### Repair kit

**G03415**

**KR pole mount with insert**

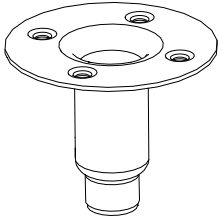

x1

D101989

threaded pole socket (with plug)

**G03413**

**KR screws and fasteners KS21**



x4

S100110

M6x25 Torx

### Exploded view



For safety reasons, always use the new screws and spare parts provided in the KR.  
If no new screws are available, use blue threadlocker.



If the speaker gasket is damaged, remove and replace it.  
Stick the new gasket to the cabinet.

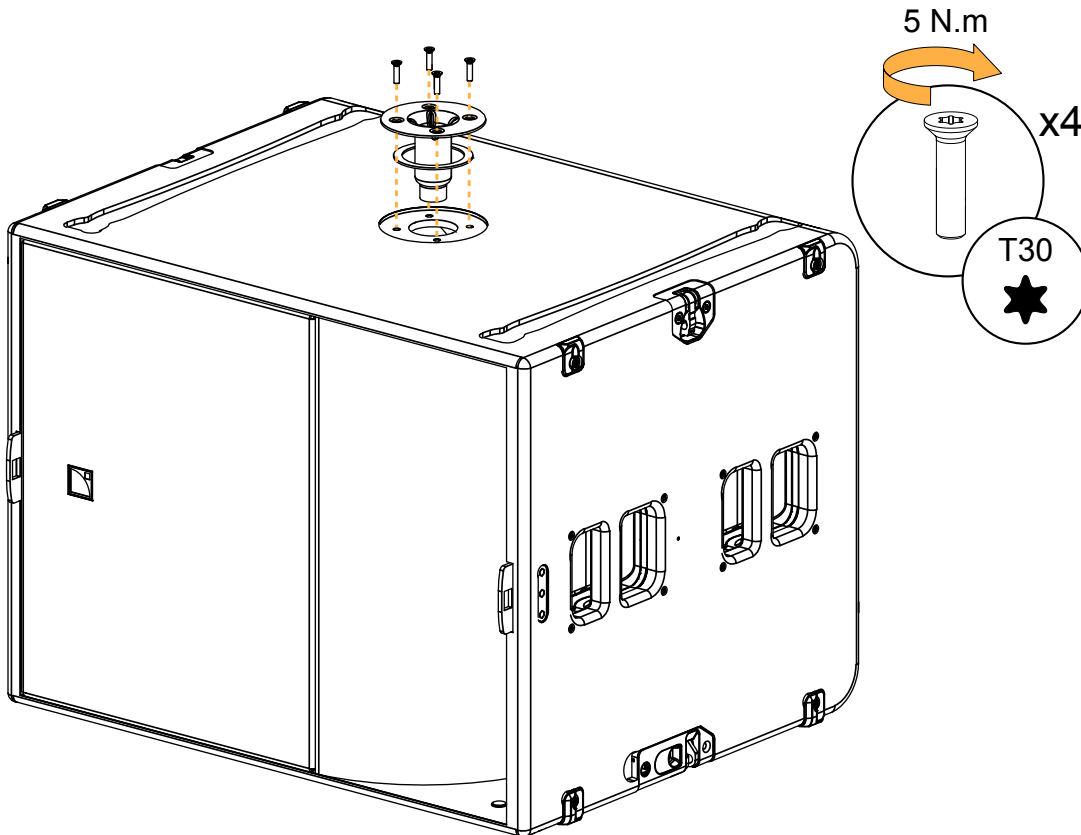

# Specifications

## A15 Focus specifications

---

|                                    |   |
|------------------------------------|---|
| <b>Description</b>                 | 2-way passive constant curvature WST® 10° enclosure: 15" LF + 3" HF diaphragm, amplified by LA4X / LA8 / LA12X                    |
| <b>Usable bandwidth (-10 dB)</b>   | 41 Hz - 20 kHz ([A15])  |
| <b>Maximum SPL<sup>1</sup></b>     | 144 dB ([A15])  |
| <b>Nominal directivity (-6 dB)</b> | enclosure: 10°<br>L-Fins: 70° / 110° symmetric or 90° asymmetric (-6 dB)  |
| <b>Transducers</b>                 | LF: 1 × 15" cone driver - neodymium<br>HF: 1 × 3" diaphragm compression driver - neodymium  |
| <b>Acoustical load</b>             | LF: bass-reflex, L-Vents<br>HF: DOSC waveguide, L-Fins  |
| <b>Nominal impedance</b>           | 8 Ω   |
| <b>Connectors</b>                  | IN: 1 × 4-point speakON<br>LINK: 1 × 4-point speakON  |
| <b>Rigging and handling</b>        | flush-fitting 2-point rigging system<br>2 handles<br>8 corner stops<br>2 ground runners<br>1 DIN580-compatible M8 threaded insert |
| <b>Weight (net)</b>                | 35 kg / 77 lb   |
| <b>Cabinet</b>                     | premium grade Baltic beech and birch plywood  |
| <b>Front</b>                       | coated steel grill<br>acoustically neutral 3D fabric  |
| <b>Rigging components</b>          | high grade steel with anti-corrosion coating  |
| <b>Finish</b>                      | dark grey brown Pantone 426 C   |
| <b>IP</b>                          | IP55  |

<sup>1</sup> Peak level at 1 m under free field conditions using pink noise with crest factor 4 (preset specified in brackets).

## A15 Focus dimensions

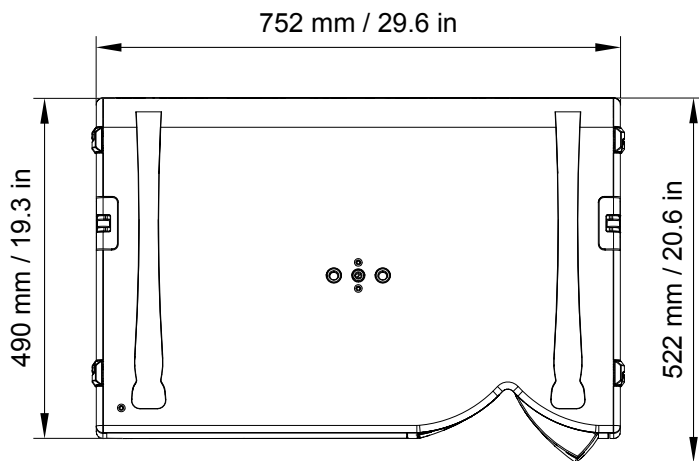
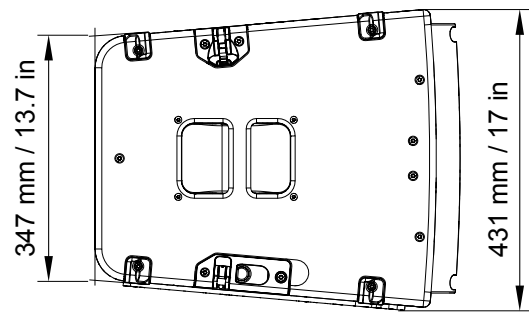
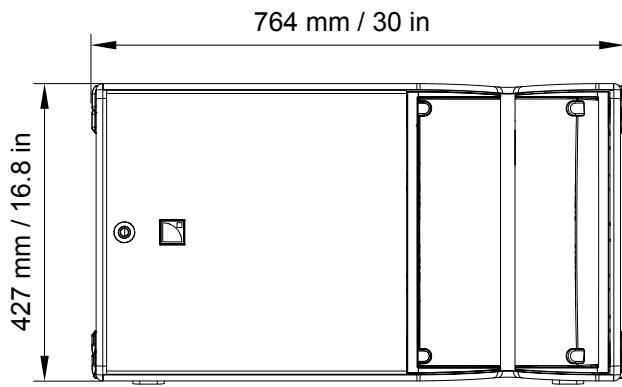

## A15 Wide specifications

---

|                                    |   |
|------------------------------------|---|
| <b>Description</b>                 | 2-way passive constant curvature WST® 30° enclosure: 15" LF+ 3" HF diaphragm, amplified by LA4X / LA8 / LA12X                     |
| <b>Usable bandwidth (-10 dB)</b>   | 42 Hz - 20 kHz([A15])   |
| <b>Maximum SPL<sup>1</sup></b>     | 141 dB ([A15])  |
| <b>Nominal directivity (-6 dB)</b> | enclosure: 30°<br>L-Fins: 70° / 110° symmetric or 90° asymmetric (-6 dB)  |
| <b>Transducers</b>                 | LF: 1 × 15" cone driver - neodymium<br>HF: 1 × 3" diaphragm compression driver - neodymium  |
| <b>Acoustical load</b>             | LF: bass-reflex, L-Vents<br>HF: DOSC waveguide, L-Fins  |
| <b>Nominal impedance</b>           | 8 Ω   |
| <b>Connectors</b>                  | IN: 1 × 4-point speakON<br>LINK: 1 × 4-point speakON  |
| <b>Rigging and handling</b>        | flush-fitting 2-point rigging system<br>2 handles<br>8 corner stops<br>2 ground runners<br>1 DIN580-compatible M8 threaded insert |
| <b>Weight (net)</b>                | 33 kg / 73 lb   |
| <b>Cabinet</b>                     | premium grade Baltic beech and birch plywood  |
| <b>Front</b>                       | coated steel grill<br>acoustically neutral 3D fabric  |
| <b>Rigging components</b>          | high grade steel with anti-corrosion coating  |
| <b>Finish</b>                      | dark grey brown Pantone 426 C   |
| <b>IP</b>                          | IP55  |

<sup>1</sup> Peak level at 1 m under free field conditions using pink noise with crest factor 4 (preset specified in brackets).

## A15 Wide dimensions

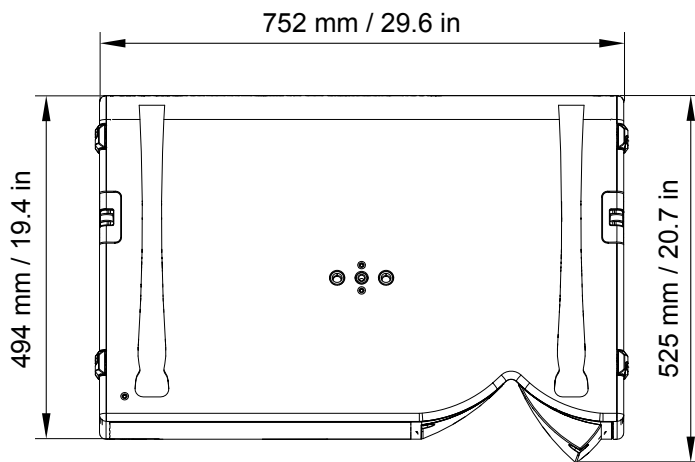
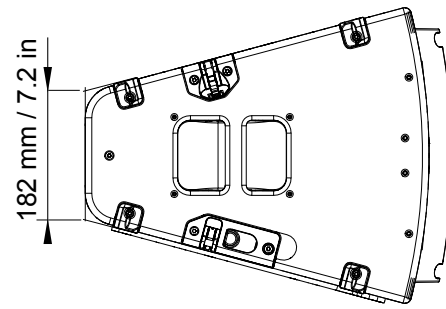
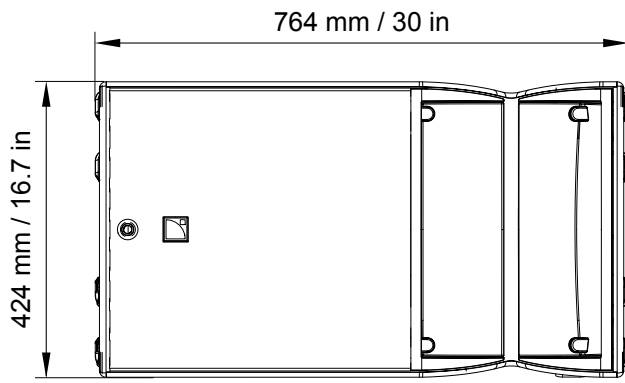

## KS21 specifications

---

|                                     |   |
|-------------------------------------|---|
| <b>Description</b>                  | High power compact subwoofer: 1x21" , amplified by LA4X / LA8 / LA12X   |
| <b>Low frequency limit (-10 dB)</b> | 31 Hz ([KS21_100])  |
| <b>Maximum SPL<sup>1</sup></b>      | 138 dB ([KS21_100])   |
| <b>Nominal directivity (-6 dB)</b>  | standard or cardioid configuration  |
| <b>Transducers</b>                  | 1 × 21" neodymium cone driver   |
| <b>Acoustical load</b>              | bass-reflex, L-Vents  |
| <b>Nominal impedance</b>            | 8 Ω   |
| <b>Connectors</b>                   | IN: 1 × 4-point speakON<br>LINK: 1 × 4-point speakON  |
| <b>Rigging and handling</b>         | flush-fitting 2-point rigging system<br>4 handles<br>8 corner stops<br>2 ground runners<br>1 pole mount with M20×150 insert |
| <b>Weight (net)</b>                 | 49 kg / 108 lb  |
| <b>Cabinet</b>                      | premium grade Baltic beech and birch plywood  |
| <b>Front</b>                        | coated steel grill<br>acoustically neutral 3D fabric  |
| <b>Rigging components</b>           | high grade steel with anti-corrosion coating  |
| <b>Finish</b>                       | dark grey brown Pantone 426 C   |
| <b>IP</b>                           | IP55  |

<sup>1</sup> Peak level at 1 m under half space conditions using pink noise with crest factor 4 (preset specified in brackets).

### KS21 dimensions

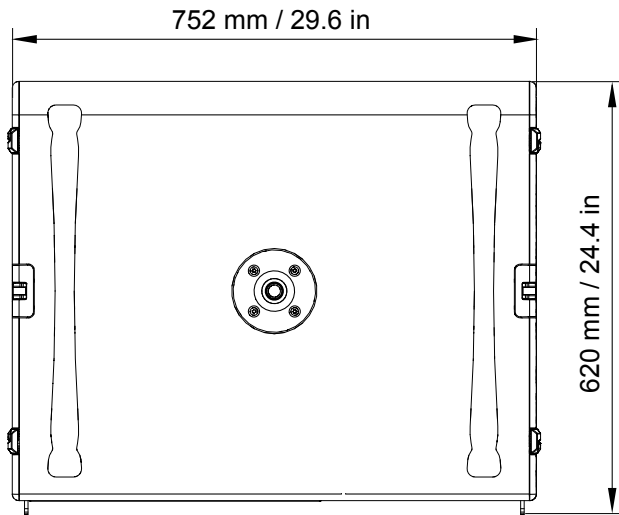
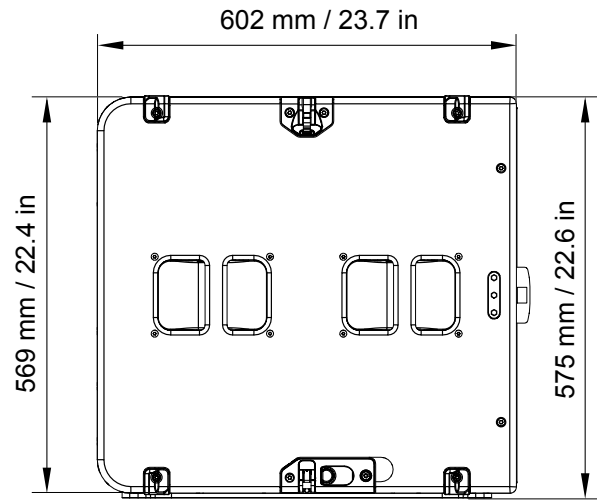
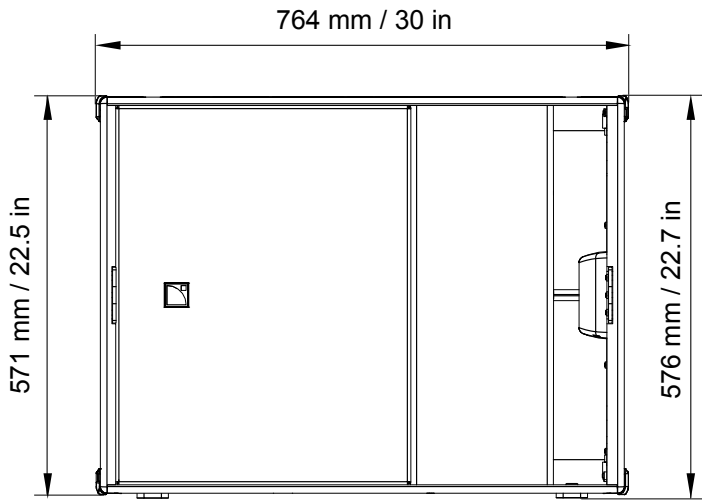



## A15-BUMP specifications

---

|                     |   |
|---------------------|---|
| <b>Description</b>  | Flying frame for vertical deployment of A15 and KS21<br>2 x Ø12 mm shackles WLL 1 t |
| <b>Weight (net)</b> | 19 kg / 42 lb   |
| <b>Material</b>     | high grade steel with anti-corrosion coating  |

## A15-BUMP dimensions

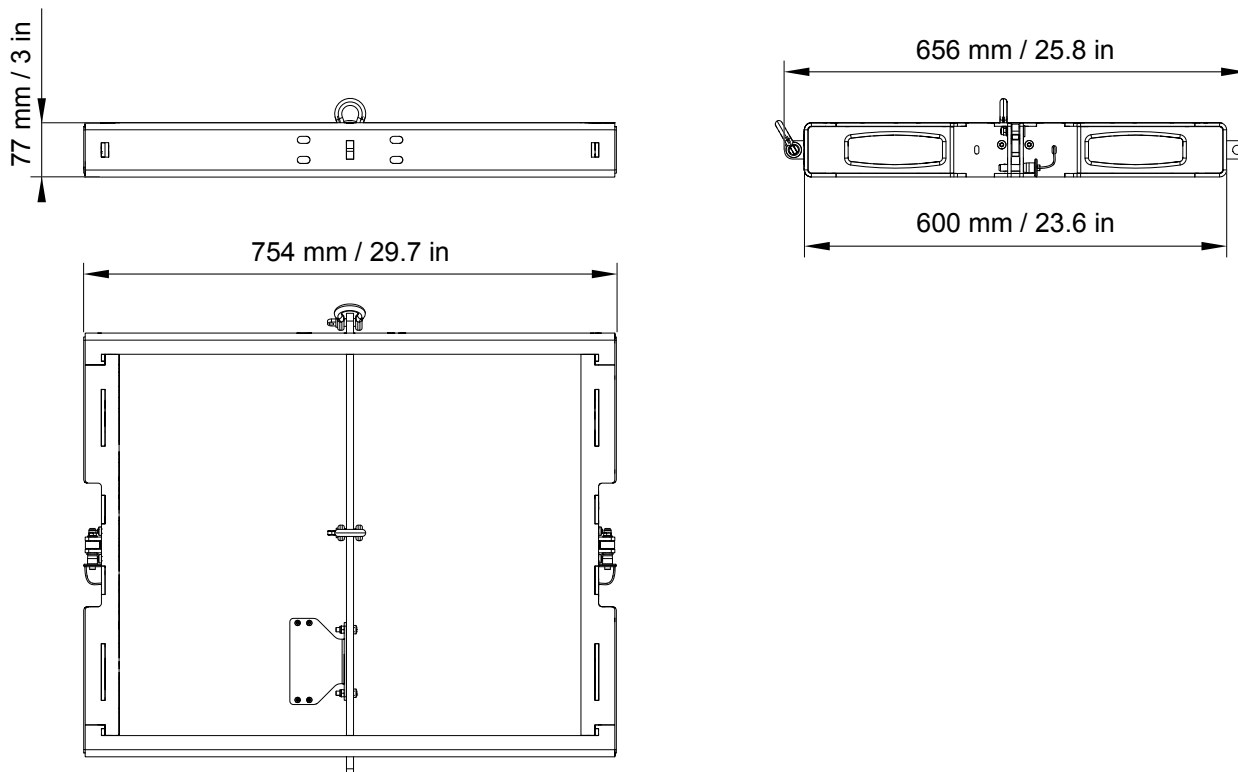

## A15-LIFT specifications

---

|                     |   |
|---------------------|---|
| <b>Description</b>  | Rigging element for horizontal deployment of A15<br>2 × Ø12 mm shackles WLL 1 t |
| <b>Weight (net)</b> | 2.3 kg / 5.1 lb   |
| <b>Material</b>     | high grade steel with anti-corrosion coating                                    |

### A15-LIFT dimensions

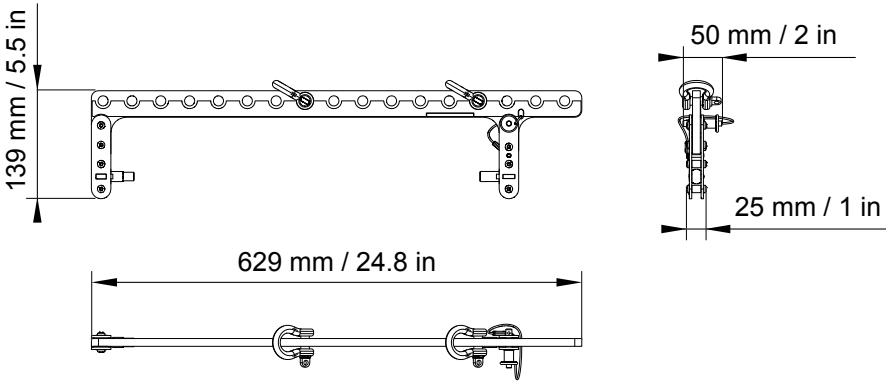

## A15-RIGBAR specifications

---

|                     |  |
|---------------------|--|
| <b>Description</b>  | Rigging bar and pullback for A15 and KS21<br>2 x Ø12 mm shackles WLL 1 t |
| <b>Weight (net)</b> | 4.6 kg / 10 lb   |
| <b>Material</b>     | high grade steel with anti-corrosion coating                             |

### A15-RIGBAR dimensions

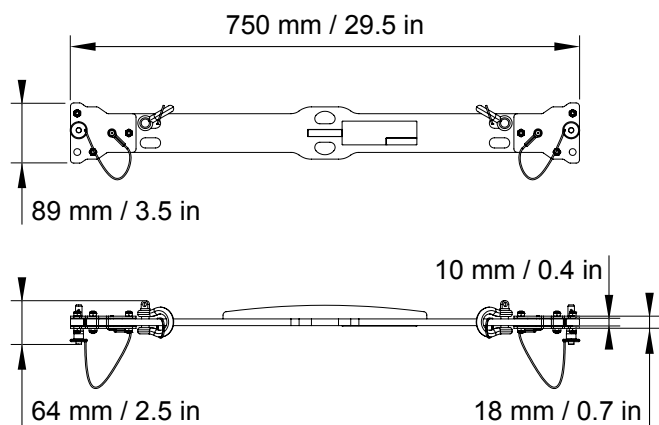

## A-TILT specifications

|                     |  |
|---------------------|--|
| <b>Description</b>  | Rigging element for stacking A15 and A10 onto KS21 |
| <b>Weight (net)</b> | 8.7 kg / 19.2 lb                                   |
| <b>Material</b>     | high grade steel with anti-corrosion coating       |

## A-TILT dimensions

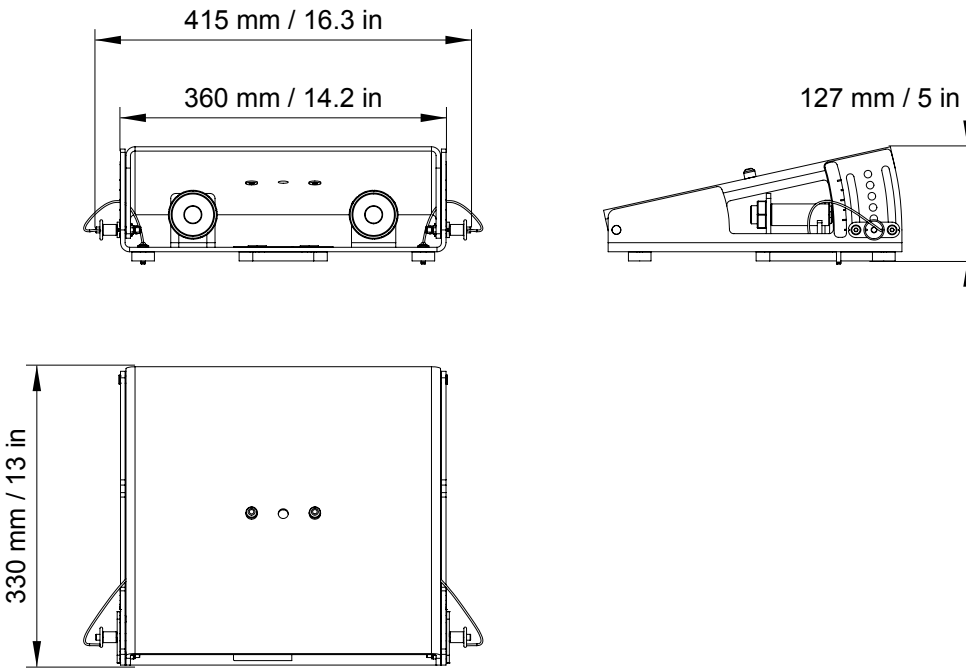

## KS21-OUTRIG specifications

**!** **Specifications for one KS21-OUTRIG bar.**  
Always use in pairs.

|                             |   |
|-----------------------------|---|
| <b>Description</b>          | Stability bars for KS21   |
| <b>Weight (net)</b>         | 3.5 kg / 7.7 lb   |
| <b>Rigging and handling</b> | 2 ground runners  |
| <b>Material</b>             | high grade steel with anti-corrosion coating, high density polyethylene (runners) |

## KS21-OUTRIG dimensions

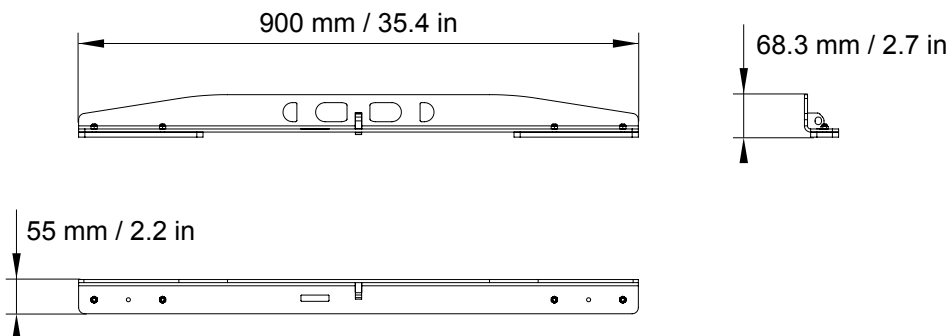

## A-MOUNT specifications

---

|                     |  |
|---------------------|--|
| <b>Description</b>  | Pole mount for A15 and A10                   |
| <b>Weight (net)</b> | 1.1 kg / 2.4 lb                              |
| <b>Material</b>     | high grade steel with anti-corrosion coating |

## A-MOUNT dimensions

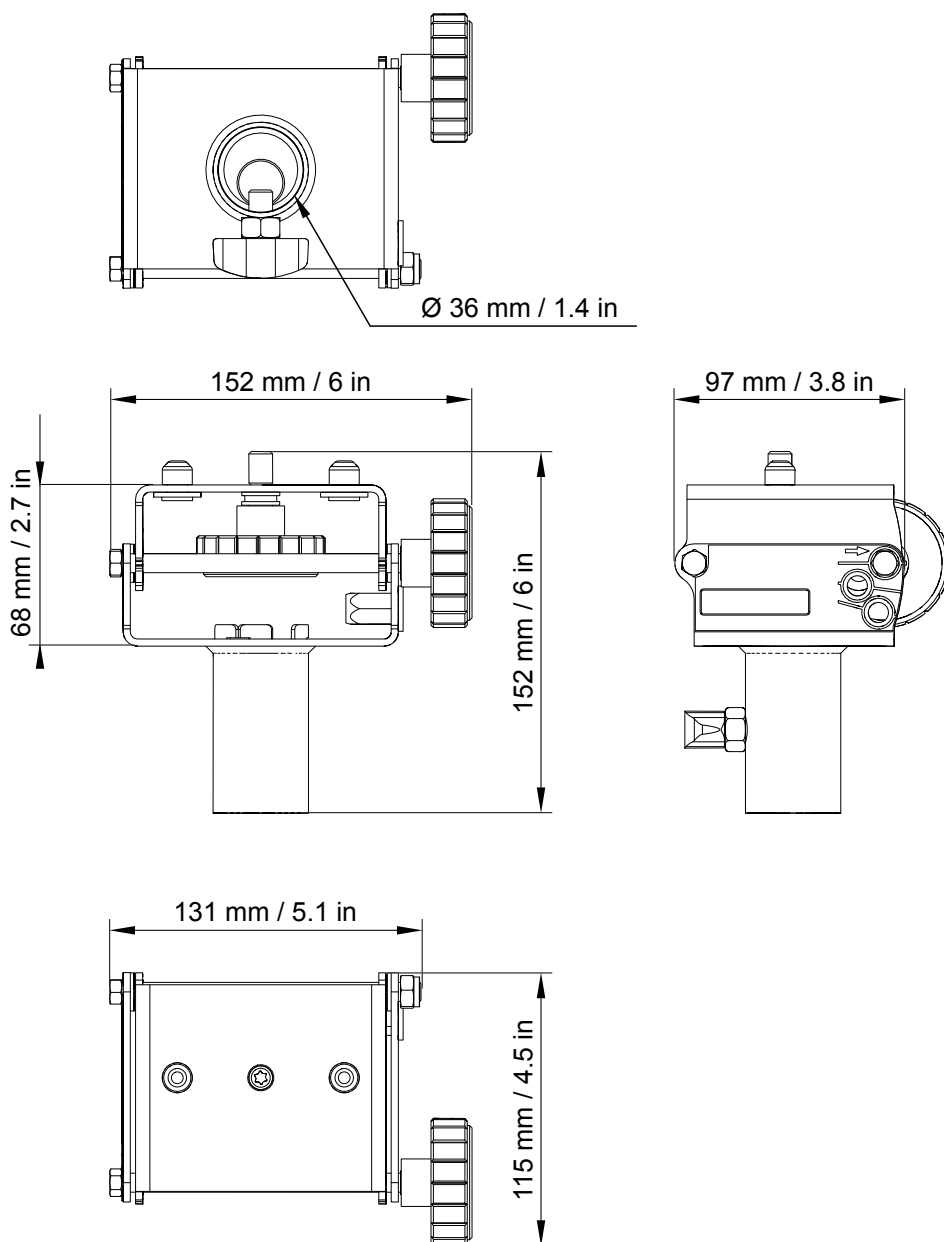

## KS21-CHARIOT specifications

---

|                     |                          |
|---------------------|--------------------------|
| <b>Description</b>  | Chariot for up to 3 KS21 |
| <b>Weight (net)</b> | 23.6 kg / 52 lb          |

### KS21-CHARIOT dimensions

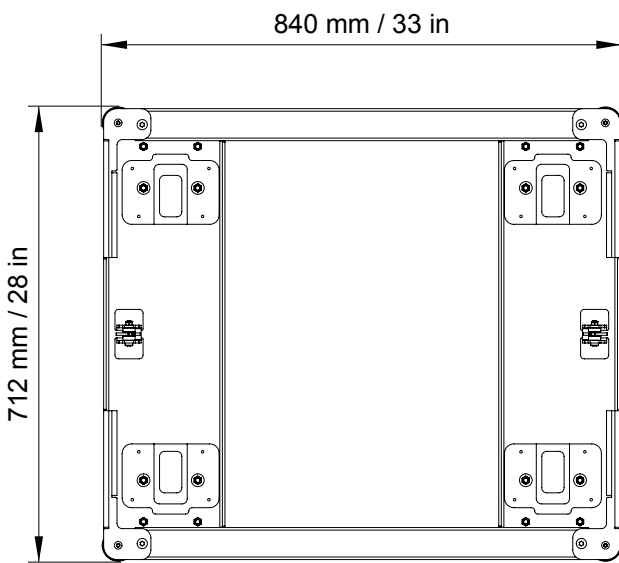
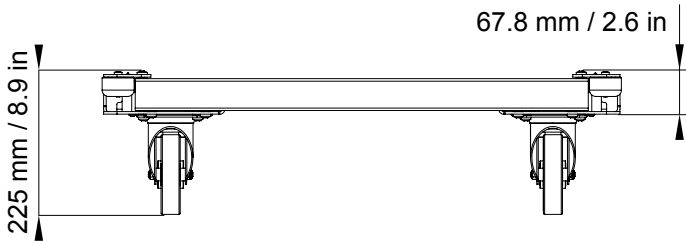

## K2-JACK specifications

---

|                     |  |
|---------------------|--|
| <b>Description</b>  | 4 tilt adjustment screw jacks + bar for K2-CHARIOT |
| <b>Weight (net)</b> | 10.1 kg / 22.3 lb (for one stabilizer)             |
| <b>Material</b>     | high grade steel with anti-corrosion coating       |

### K2-JACK dimensions

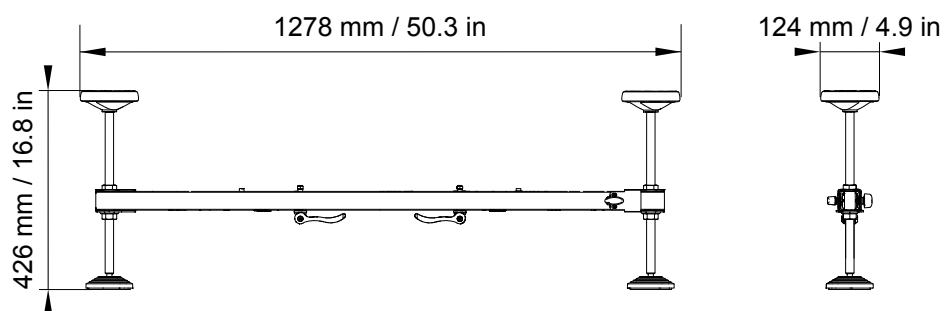

## M-BAR specifications

---

|                     |   |
|---------------------|---|
| <b>Description</b>  | Extension bar for rigging frame<br>2 x Ø19 mm shackles WLL 3.25 t |
| <b>Weight (net)</b> | 5 kg / 11 lb  |
| <b>Material</b>     | high grade steel with anti-corrosion coating                      |

## M-BAR dimensions

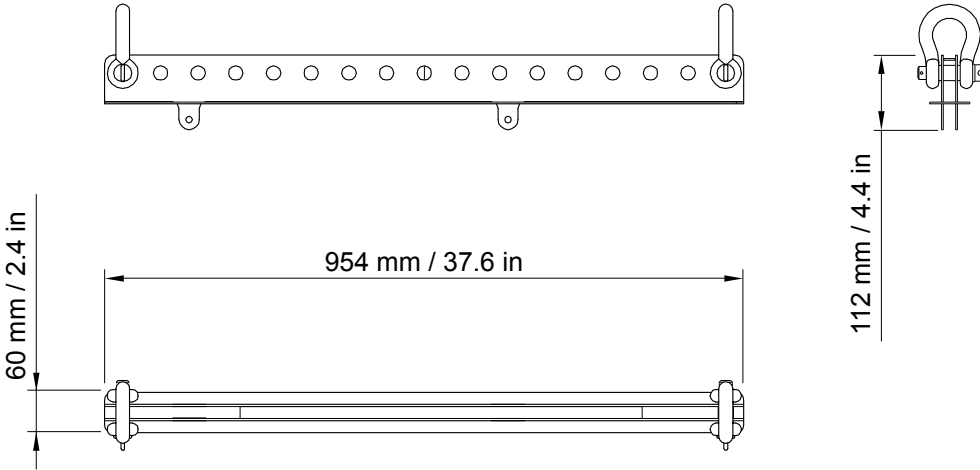



## X-BAR specifications

---

|                     |   |
|---------------------|---|
| <b>Description</b>  | Rigging bar for 1 enclosure<br>1 x Ø12 mm shackle WLL 1 t |
| <b>Weight (net)</b> | 1.1 kg / 2.4 lb   |
| <b>Material</b>     | high grade steel with anti-corrosion coating              |

### X-BAR dimensions

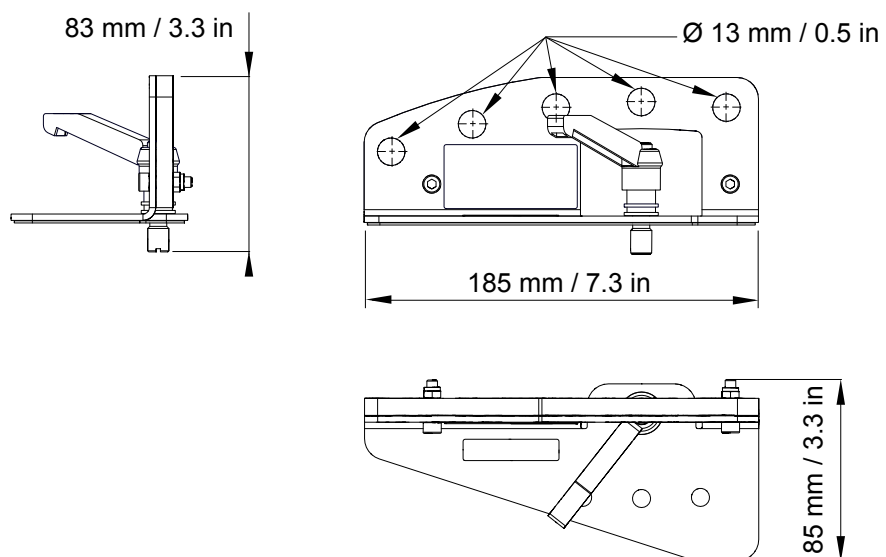

## CLAMP250 specifications

---

|                     |  |
|---------------------|--|
| <b>Description</b>  | Clamp certified for 250 kg                   |
| <b>Weight (net)</b> | 1.8 kg / 4 lb                                |
| <b>Material</b>     | high grade steel with anti-corrosion coating |

## CLAMP250 dimensions

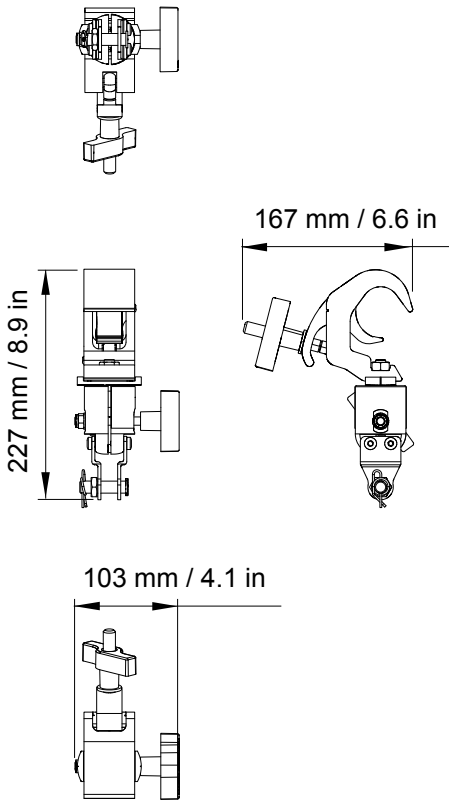

## KS21-PLA specifications

---

**Description** Removable front dolly for 1 KS21

**Weight (net)** 9.5 kg / 21 lb

### KS21-PLA dimensions

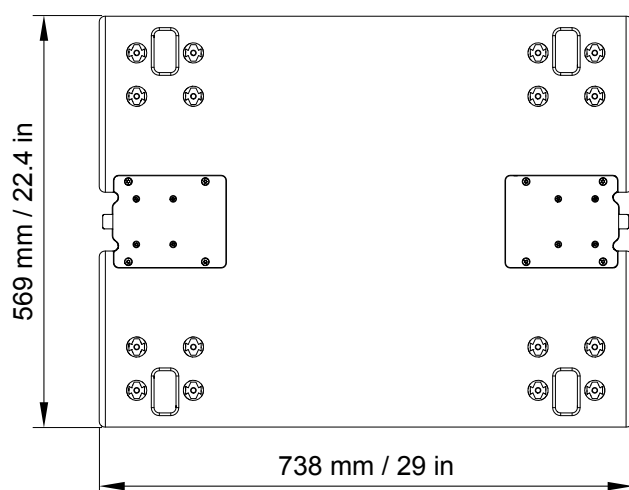
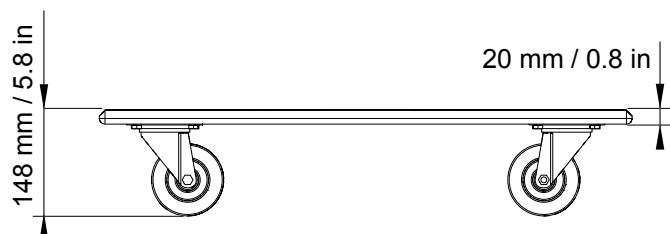

# Authorized configurations with A15-LIFT

## Safety instructions

### Additional safety with A15-LIFT

On each enclosure on which A15-LIFT is secured, secure a DIN580 eye bolt to the dedicated insert to implement a secondary safety.

Use a shackle and a steel wire rope. Make sure the steel rope is as tensed as possible without bearing the load.

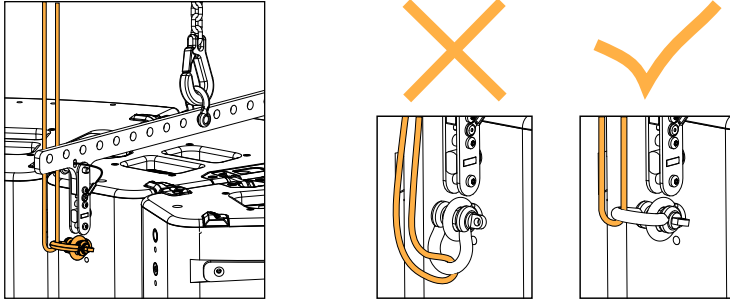

### A15-LIFT quantity and position

Use one A15-LIFT for up to three enclosures in the array.

Do not leave more than two adjacent enclosures unsupported.

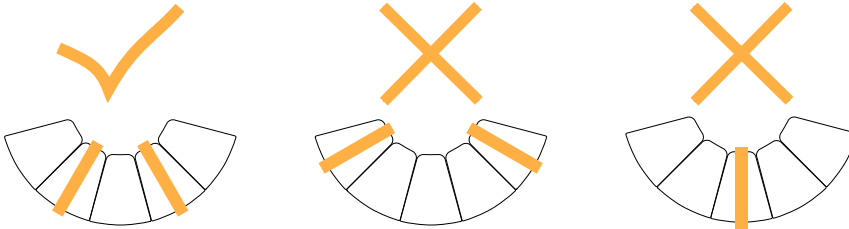

### A15-LIFT pickup point

Select the same pickup point on each A15-LIFT within an array of up to 6 enclosures.

For larger arrays, refer to [Radial arrays of 7 enclosures and more](#) (p.151).

### Risk of tilting

When using a single motor or a bridle, make sure the array is symmetrical.

 When using a third-party bridle, make sure the angle between the two chains does not exceed 60°.

### Hybrid configurations

Either A15 Wide, A15 Focus or a combination of both can be used as illustrated.

## Radial arrays of 1 to 6 enclosures

Refer to the illustrations to distribute the A15-LIFT bars on the array.



1 enclosure :  
1 A15-LIFT



2 enclosures :  
2 A15-LIFT



3 enclosures :  
1 A15-LIFT



4 enclosures : 2 A15-LIFT

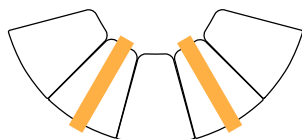

5 enclosures : 2 A15-LIFT

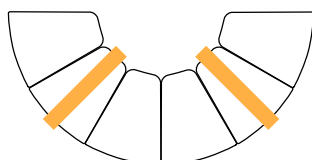

6 enclosures : 2 A15-LIFT

## Radial arrays of 7 enclosures and more

Refer to the illustrations to distribute the A15-LIFT bars on the array.

**⚠ In radial arrays of 7 enclosures and more, make sure the site angle is 0°.**  
Position the pickup points so that the center of gravity is in the middle of the array.

**ⓘ Setup point for radial arrays of 7 enclosures and more**  
For each configuration, use the indicated setup point during assembly.

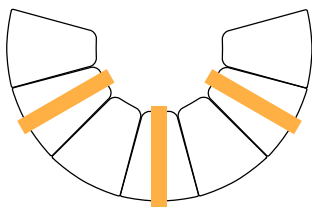

7 enclosures : 3 A15-LIFT

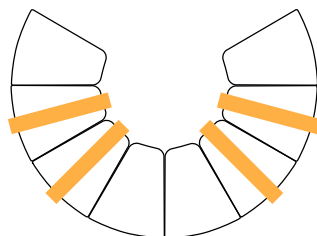

8 enclosures : 4 A15-LIFT

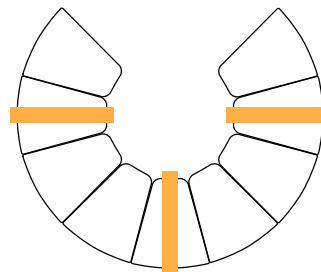

9 enclosures : 3 A15-LIFT

### Array setup information

| type      | number of enclosures | number of motors | setup point | pickup point for 0° site angle |
|-----------|----------------------|------------------|-------------|--------------------------------|
| A15 Focus | 7                    | 3                | 11          | N/A                            |
|           | 8                    | 2 (2 bridles)    | 11          | 8                              |
|           | 9                    | 3                | 13          | N/A                            |
| A15 Wide  | 7                    | 3                | 13          | N/A                            |
|           | 8                    | 2 (2 bridles)    | 13          | 13                             |
|           | 9                    | 3                | 17          | N/A                            |

# Installing an inclinometer on A15-BUMP

## Tools

- torque screwdriver
- T20 Torx bit
- 7 mm wrench

## About this task

A15-BUMP is equipped with a support plate for installing an optional inclinometer. Three models are compatible: TEQSAS® LAP-TEQ PLUS (provided in the **TECH TOOLCASE**), TEQSAS® LAP-TEQ (legacy model), and KSG® RECLINE Compact.

### **LAP-TEQ / LAP-TEQ PLUS sensor and display compatibility**

The legacy LAP-TEQ sensors are compatible with the new TEQSAS® LAP-TEQ PLUS displays. Conversely, the new sensors are **not** compatible with the legacy displays.

With two sets of fixation points and eight slit openings, the position and orientation of the laser support plate can be adapted to every use of the rigging frame.

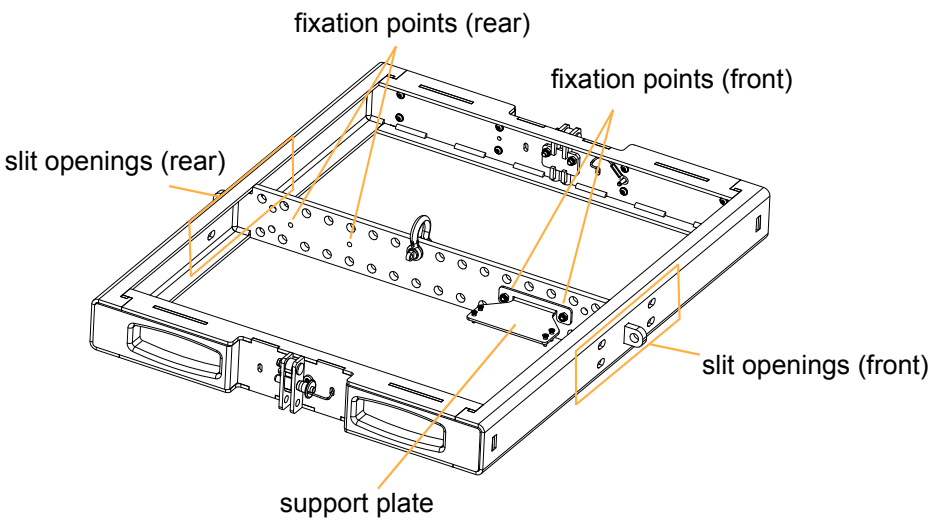

### **Calibrating the inclinometer**

Refer to the manufacturer instructions.  
An additional XLR cable is needed.

## Exploded view

Use the screws and nuts provided with A15-BUMP.

Before tightening the screws, align the laser with the slit opening.

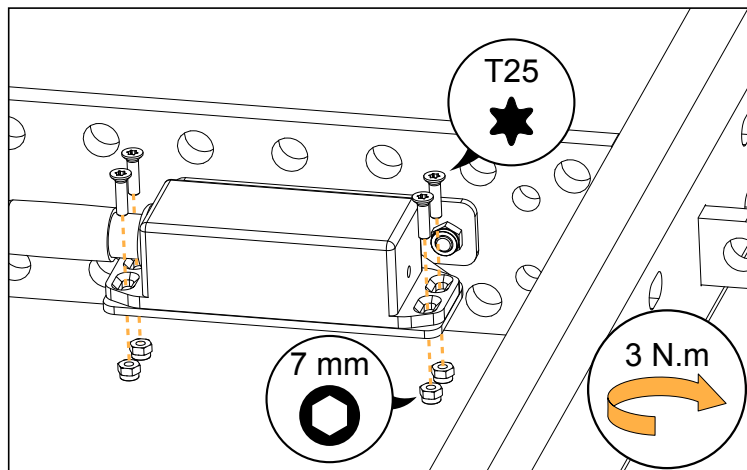

## Recommendation for speaker cables

Follow the recommended maximum length for loudspeaker cables to ensure minimal SPL attenuation.



### Cable quality and resistance

Only use high-quality fully insulated speaker cables made of stranded copper wire.

Use cables with a gauge offering low resistance per unit length and keep the cables as short as possible.

The table below provides the recommended maximum length for loudspeaker cables depending on the cable gauge and on the impedance load connected to the amplifier.

| cable gauge     |     |     | recommended maximum length |     |          |     |            |    |
|-----------------|-----|-----|----------------------------|-----|----------|-----|------------|----|
|                 |     |     | 8 Ω load                   |     | 4 Ω load |     | 2.7 Ω load |    |
| mm <sup>2</sup> | SWG | AWG | m                          | ft  | m        | ft  | m          | ft |
| 2.5             | 15  | 13  | 30                         | 100 | 15       | 50  | 10         | 33 |
| 4               | 13  | 11  | 50                         | 160 | 25       | 80  | 17         | 53 |
| 6               | 11  | 9   | 74                         | 240 | 37       | 120 | 25         | 80 |

Use the more detailed L-Acoustics calculation tool to evaluate cable length and gauge based on the type and number of enclosures connected. The calculation tool is available on our website:

<https://www.l-acoustics.com/installation-tools/>



**L-Acoustics**

13 rue Levacher Cintrat - 91460 Marcoussis - France  
+33 1 69 63 69 63 - [info@l-acoustics.com](mailto:info@l-acoustics.com)  
[www.l-acoustics.com](http://www.l-acoustics.com)

 **L-ACOUSTICS**  
GROUP