

K2

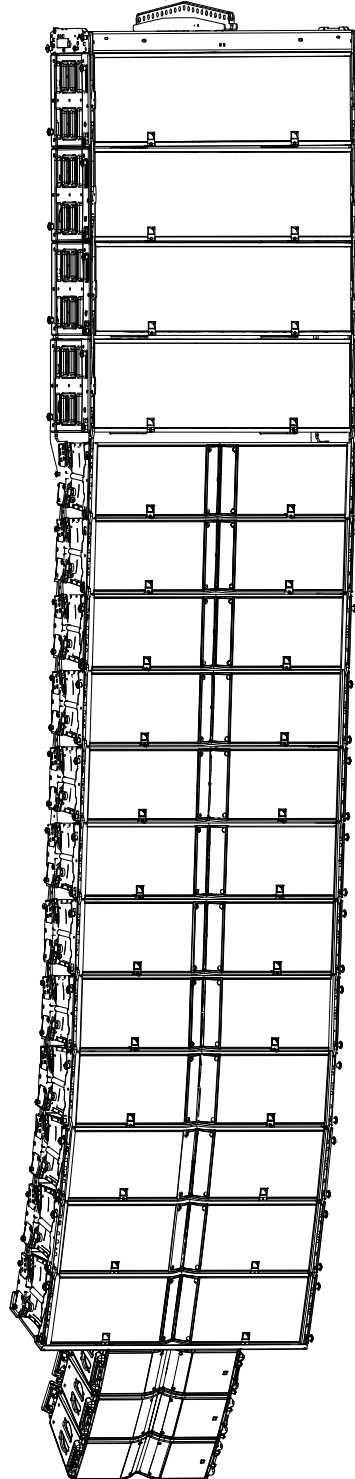

owner's manual (EN)



Document reference: K2 owner's manual (EN) version 2.0

Distribution date: February 28, 2020

© 2020 L-Acoustics. All rights reserved.

No part of this publication may be reproduced or transmitted in any form or by any means without the express written consent of the publisher.

Contents

Safety.....	6
Instructions.....	6
Introduction.....	8
K2 variable curvature WST line source.....	8
How to use this manual.....	8
System components.....	10
Loudspeaker cables.....	11
Rigging elements.....	12
Electro-acoustical description.....	13
K2 horizontal directivity settings.....	13
K2 directivity.....	14
K1-SB applications.....	15
Preset description.....	16
Connectors.....	17
Rigging system description.....	19
Elements for enclosure rigging.....	19
Elements for storage and transportation.....	20
Elements for ground stacking.....	21
Elements for flying.....	22
Elements for LA-RAK/LA-RAK II rigging.....	26
Mechanical safety.....	28
Loudspeaker configurations.....	31
K2 line source.....	31
Additional subwoofer system.....	33
K1-SB.....	34
KS28.....	37
SB28.....	39
Additional downfill element.....	41
Kara II.....	41
Inspection and preventive maintenance.....	42
How to do preventive maintenance.....	42
Rigging part inspection.....	43
Mechanical system overview.....	43
K2 mixed array with K2-BAR, K2-BUMP, K1-SB, and K2-LINK.....	44

K2 array with K2-BUMP and KARADOWNK2.....	45
K2 array with K2-CHARIOT and K2-JACK.....	46
K2 array with K2-BAR, K2-RAKMOUNT, and K2-BUMP.....	47
K2 array with K2-RIGBAR as pullback.....	48
Inspection references.....	49
Ball-locking pins.....	49
Shackles.....	52
Grill safety.....	53
Rigging check.....	54
Acoustical check.....	57
Rigging procedures.....	61
System setup.....	61
Ground stacking.....	61
Flying.....	63
Subset procedures.....	69
A - Preparing a block of 4 K2.....	69
B - Preset the inter-enclosure angles.....	73
C - Attaching K2-JACK stabilizers to K2-CHARIOT.....	75
D - Changing the position of the K2-CHARIOT rear rigging arm.....	80
E - Adjusting the K2-CHARIOT site angle.....	83
F - Stacking K2 on K2-BUMP.....	85
G - Attaching K2-BAR to K2-BUMP.....	89
H - Attaching a block of four K2 under K2-BUMP.....	92
I - Attaching a block of four K2 under K2-RIGBAR.....	97
J - Attaching a block of four K2 under K2.....	100
K - Attaching a block of four K2 under a K1 system element.....	106
L - Attaching K1 or K1-SB under K2-BUMP.....	113
M - Mounting LA-RAK/LA-RAK II on K2-BUMP.....	115
N - Using a K2-RIGBAR to implement a pullback.....	120
O - Rigging a Kara II downfill array under a K2 array.....	123
Connection to LA amplified controllers.....	127
Corrective maintenance.....	129
K2.....	129
K1-SB.....	148
SB28.....	153
K2-BUMP.....	156
K2-BAR.....	159

Specifications.....	161
APPENDIX A: Pickup points guidelines.....	181
APPENDIX B: Installing a laser inclinometer.....	185
APPENDIX C: Recommendation for speaker cables.....	191

Safety

Instructions



Inspect the system before any deployment.

Perform safety related checks and inspections before any deployment.

Perform preventive maintenance at least once a year.

Refer to the preventive maintenance section for a list of actions and their periodicity.

Insufficient upkeep of the product can void the warranty.

If any safety issue is detected during inspection, do not use the product before performing corrective maintenance.

Check for issues. A rigging system part or fastener is missing or loose. A rigging system part exhibits: bends, breaks, broken parts, corrosion, cracks, cracks in welded joints, deformation, denting, wear, holes. A safety cue or label is missing. A loose part is not adequately secured.



Never incorporate equipment or accessories not approved by L-Acoustics.

Read all the related PRODUCT INFORMATION documents shipped with the products before exploiting the system.



Do not store the product on an unstable cart, stand, tripod, bracket, or table.



Beware of sound levels.

Do not stay within close proximity of loudspeakers in operation.

Loudspeaker systems are capable of producing very high sound pressure levels (SPL) which can instantaneously lead to permanent hearing damage to performers, production crew and audience members. Hearing damage can also occur at moderate level with prolonged exposure to sound.

Check the applicable laws and regulations relating to maximum sound levels and exposure times.



Work with qualified personnel for rigging the system

Installation should only be carried out by qualified personnel that are familiar with the rigging techniques and safety recommendations outlined in this manual.

Ensure personnel health and safety

During installation and set-up personnel must wear protective headgear and footwear at all times. Under no circumstances is personnel allowed to climb on a loudspeaker assembly.

Respect the Working Load Limit (WLL) of third party equipment.

L-Acoustics is not responsible for any rigging equipment and accessories provided by third party manufacturers.

Verify that the Working Load Limit (WLL) of the suspension points, chain hoists and all additional hardware rigging accessories is respected.

Respect the maximum configurations and the recommended safety precautions.

For safety issue, respect the maximum configurations outlined in this manual. To check the conformity of any configuration in regards with the safety precautions recommended by L-Acoustics, model the system in Soundvision and refer to the warnings in Mechanical Data section.

Be cautious when flying a loudspeaker configuration.

Before installing/raising the product, check each individual element to make sure that it is securely fastened to the adjacent element. Always verify that no one is standing underneath the product when it is being installed/raised. Never leave the product unattended during the installation process.

As a general rule, L-Acoustics recommends the use of secondary safety at all times.

Be cautious when ground-stacking a loudspeaker array.

Do not stack the loudspeaker array on unstable ground or surface. If the array is stacked on a structure, platform, or stage, always check that the latter can support the total weight of the array.

As a general rule, L-Acoustics recommends the use of safety straps at all times.

Risk of falling objects

Verify that no unattached items remain on the product or assembly.

Risk of tipping

Remove all rigging accessories before transporting a product or an assembly.

Take into account the wind effects on dynamic load.

When a loudspeaker assembly is deployed in an open air environment, wind can produce dynamic stress to the rigging components and suspension points.

If the wind force exceeds 6 bft (Beaufort scale), lower down and/or secure the product or the assembly.

**Intended use**

This system is intended for use by trained personnel for professional applications.

**Read the OWNER'S MANUAL before installing the system.**

Use the loudspeaker system components described in the manual and follow the operating instructions.

As part of a continuous evolution of techniques and standards, L-Acoustics reserves the right to change the specifications of its products and the content of its documents without prior notice.

Check www.l-acoustics.com on a regular basis to download the latest document and software updates.

**Do not expose the product to extreme conditions.**

Do not expose the product to moisture (rain, mist, sea spray, steam, humidity, condensation...) or excessive heat (direct sun, radiator...) for a long period of time.

For more information, refer to the **Product protection ratings** document, available on the website.

**Read the maintenance section of this document before servicing the product.****Contact L-Acoustics for advanced maintenance.**

Any unauthorized maintenance operation will void the product warranty.

Introduction

K2 variable curvature WST line source

The K2 is the full range element of a WST® line source with variable curvature and adjustable horizontal directivity. The K2 loudspeaker enclosure is based on a 3-way active design. It comprises 4 input sections: 2 LF and 1 MF at a nominal impedance of 8 ohms, and 1 HF at a nominal impedance of 16 ohms. It features two 12" speakers and four 6.5", all direct-radiating neodymium speakers mounted in a bass-reflex enclosure, and two 3" neodymium diaphragm compression drivers coupled to individual DOOSC® waveguides and adjustable directivity fins. The transducers are implemented in a K-shape configuration. The cabinet is made of machined first grade Baltic birch plywood (for top, bottom and back panels) combined to die cast aluminum side panels to ensure maximum acoustical and mechanical integrity while reducing weight to the minimum. A four-point rigging system is integrated into the cabinet.

The K2 enclosure operates over the nominal frequency range of 35 Hz to 20 kHz. Its LF contour can be reinforced with the dedicated K1-SB extension and its bandwidth can be extended down to 25 Hz with the KS28 and SB28 subwoofers. In the horizontal plane, the directivity is adjustable down to 300 Hz, with two symmetric settings (70° or 110°) and two asymmetric settings (90° as 35°/55° or 55°/35°).

The K2 rigging system allows vertical assembly of enclosures with various inter-element angles (up to 10°), constituting a line array with variable curvature. The combination of the coplanar symmetry and the DOOSC® waveguide in the HF region ensure a perfect acoustic coupling between the elements of an array. The WST® (Wavefront Sculpture Technology) criteria are fulfilled, so that such an array can be qualified as a true line source. Any WST® line source provides a smooth tonal response and a coverage that is free of secondary lobes over the entire frequency range.

The K2 is driven and quad-amplified by the LA12X, LA8 or LA4X controller with factory presets which ensure linearization, protection, and optimization for the loudspeaker system.

How to use this manual

The K2 owner's manual is intended for all actors involved in the system design, implementation, preventive and corrective maintenance of the K2 system. It must be used as follows:

1. Read the technical description for an overview of all system elements, their features, and their compatibilities.
 - [Electro-acoustical description](#) (p.13)
 - [Rigging system description](#) (p.19)
2. Prepare the system configuration. Consider the mechanical limits and the available acoustical configurations.
 - [Mechanical safety](#) (p.28)
 - [Loudspeaker configurations](#) (p.31)
3. Before rigging the system, perform mandatory inspections and functional checks.
 - [Inspection and preventive maintenance](#) (p.42)
4. To deploy the system, follow the step-by-step rigging instructions and refer to the cabling schemes.
 - [Rigging procedures](#) (p.61)
 - [Connection to LA amplified controllers](#) (p.127)



The [Corrective maintenance](#) (p.129) section contains the operations authorized for the end user.

Performing another operation exposes to hazardous situations.

For advanced maintenance, contact your L-Acoustics representative.

As part of a continuous evolution of techniques and standards, L-Acoustics reserves the right to change the specifications of its products and the content of its document without prior notice. Please check www.l-acoustics.com on a regular basis to download the latest document and software updates.



Contact information

For information on advanced corrective maintenance:

- contact your Certified Provider or your L-Acoustics representative
- for Certified Providers, contact the L-Acoustics customer service: customer.service@l-acoustics.com

Symbols

The following symbols are used in this document:

-  This symbol indicates a potential risk of harm to an individual or damage to the product. It can also notify the user about instructions that must be strictly followed to ensure safe installation or operation of the product.
-  This symbol notifies the user about instructions that must be strictly followed to ensure proper installation or operation of the product.
-  This symbol notifies the user about complementary information or optional instructions.

System components

Loudspeaker enclosures

K2	3-way full-range active WST enclosure
K1-SB	K1 system subwoofer 2x15"
SB28	High power subwoofer: 2 x 18"
KS28	Flyable subwoofer 2 x 18"
Kara II	2-way active WST® enclosure: 2 x 8" LF + 3" HF diaphragm

Powering and driving system

LA4X / LA8 / LA12X	Amplified controller with DSP, preset library and networking capabilities
LA-RAK	Touring rack containing three LA8 and power, audio and network distribution
LA-RAK II	Touring rack containing three LA12X, LA-POWER II for power distribution and LA-PANEL II for audio and network distribution



Refer to the LA4X / LA8 / LA12X owner's manual for operating instructions.

Loudspeaker cables

SP cables	4-point speakON loudspeaker cables (4 mm ² gauge) SP cables come in four sizes: SP.7 (0.7 m/2.3 ft), SP5 (5 m/16.4 ft), SP10 (10 m/32.8 ft) and SP25 (25 m/82 ft)
SP-Y1	breakout cable for two passive enclosures (2.5 mm ² gauge) provided with a CC4FP adapter 4-point speakON to 2 x 2-point speakON
DO	8-point PA-COM loudspeaker cables (4 mm ² gauge) DO cables come in three sizes: DO.7 (0.7 m/2.3 ft), DO10 (10 m/32.8 ft) and DO25 (25 m/82 ft)
DOSUB-LA8	breakout cable for four passive enclosures (4 mm ² gauge) 8-point PA-COM to 4 x 2-point speakON
DOFILL-LA8	breakout cable for two 2-way active enclosures (4 mm ² gauge) 8-point PA-COM to 2 x 4-point speakON



Information about the connection of the enclosures to the LA amplified controllers is given in this document.

Refer to the LA4X / LA8 / LA12X owner's manual for detailed instructions about the whole cabling scheme, including modulation cables and network.

Rigging elements

K2-BUMP	Structure for flying K2 arrays (incl. 1 extension sling + 1 laser adapter)
K2-BAR	Extension bar for K2-BUMP
K1-DELTA	Rigging accessory for rear attachment of 2 motors to K1-BUMP
K2-JACK	4 tilt adjustment screw jacks + bar for K2-CHARIOT
K2-LINK	Rigging accessory for rear attachment of K2 below K1
K2-RAKMOUNT	4 mounting cradle for LA-RAK (incl. rack stabilizer)
K1-BPCHAIN	Adjustable sling for K1-BUMP or K2-BUMP

LA-SLING2T	Lifting chain (DIN EN 818-4) 2-leg , 8 mm
K2-RIGBAR	K2 rigging bar and pullback (Inc. LA-SLING2T)
K2-LASERMOUNT	K2 laser support plate (compatible TEQSAS / SSE Proslight / Align Array / KSG)
KARADOWNK2	Flying bumper for rigging Kara under K2

Transportation accessories

K2-CHARIOT	Chariot for 4 K2
K2-CHARIOTCOV	Protective cover for 4 K2 on CHARIOT
K-BUMPFLIGHT	Modular flight case for 2 K1-BUMP or 2 K2-BUMP

Software applications

Soundvision	3D acoustical and mechanical modeling software
LA Network Manager	Software for remote control and monitoring of amplified controllers



Refer to the **Soundvision** help.

Refer to the **LA Network Manager** help.

Loudspeaker cables

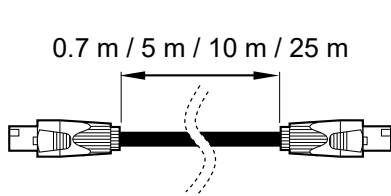

SP.7 / SP5 / SP10 / SP25

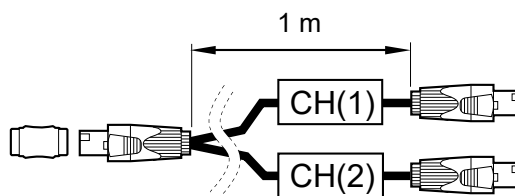

SP-Y1

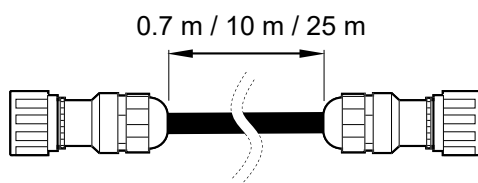

DO.7 / DO10 / DO25

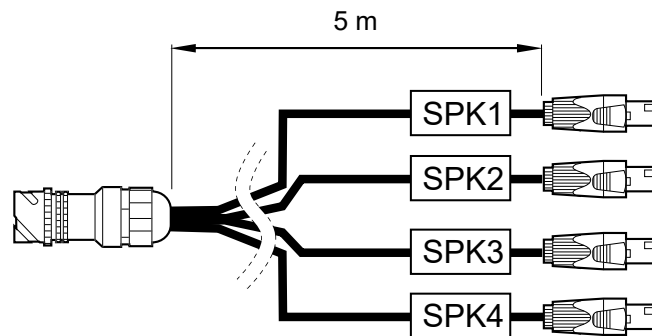

DOSUB-LA8

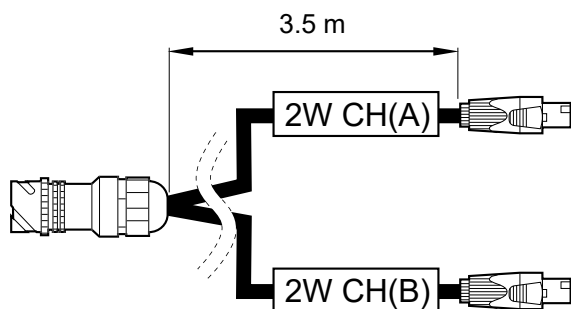

DOFILL-LA8

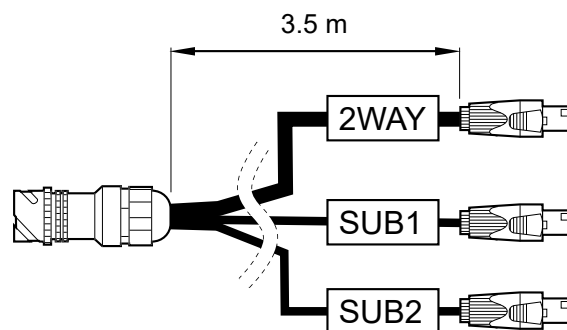

DO3WFILL

Rigging elements

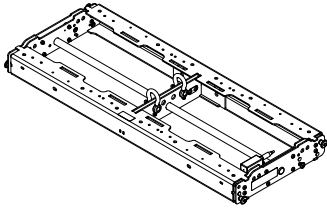

K2-BUMP

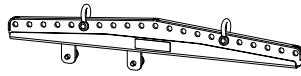

K2-BAR

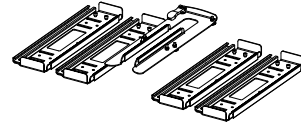

K2-RAKMOUNT

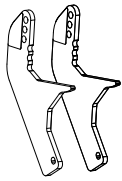

K2-LINK

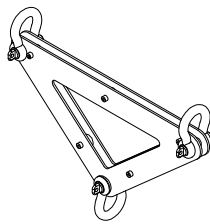

K1-DELTA

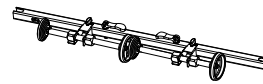

K2-JACK

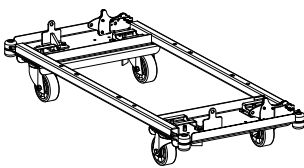

K2-CHARIOT

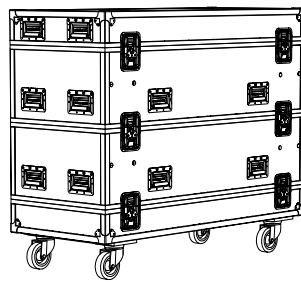

K-BUMPFLIGHT

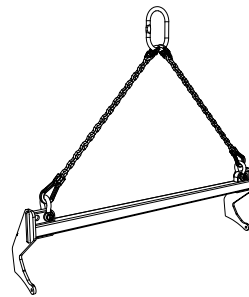

K2-RIGBAR

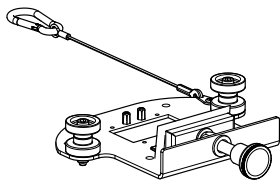

K2-LASERMOUNT

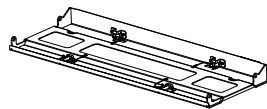

KARADOWNK2



K1-BPCHAIN



LA-SLING2T

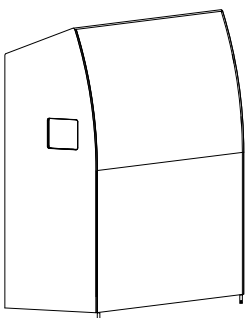

K2-CHARIOTCOV

Electro-acoustical description

K2 horizontal directivity settings

The K2 enclosure features an adjustable horizontal directivity system. Using the adjustable fins, horizontal directivity can be adjusted with four different settings: 110°/70° symmetric or 90° asymmetric (35°/55° or 55°/35°). A specific K2 preset must be used for each directivity setting.

Within a line source, different directivity settings can be combined to improve the coverage of the audience geometry.

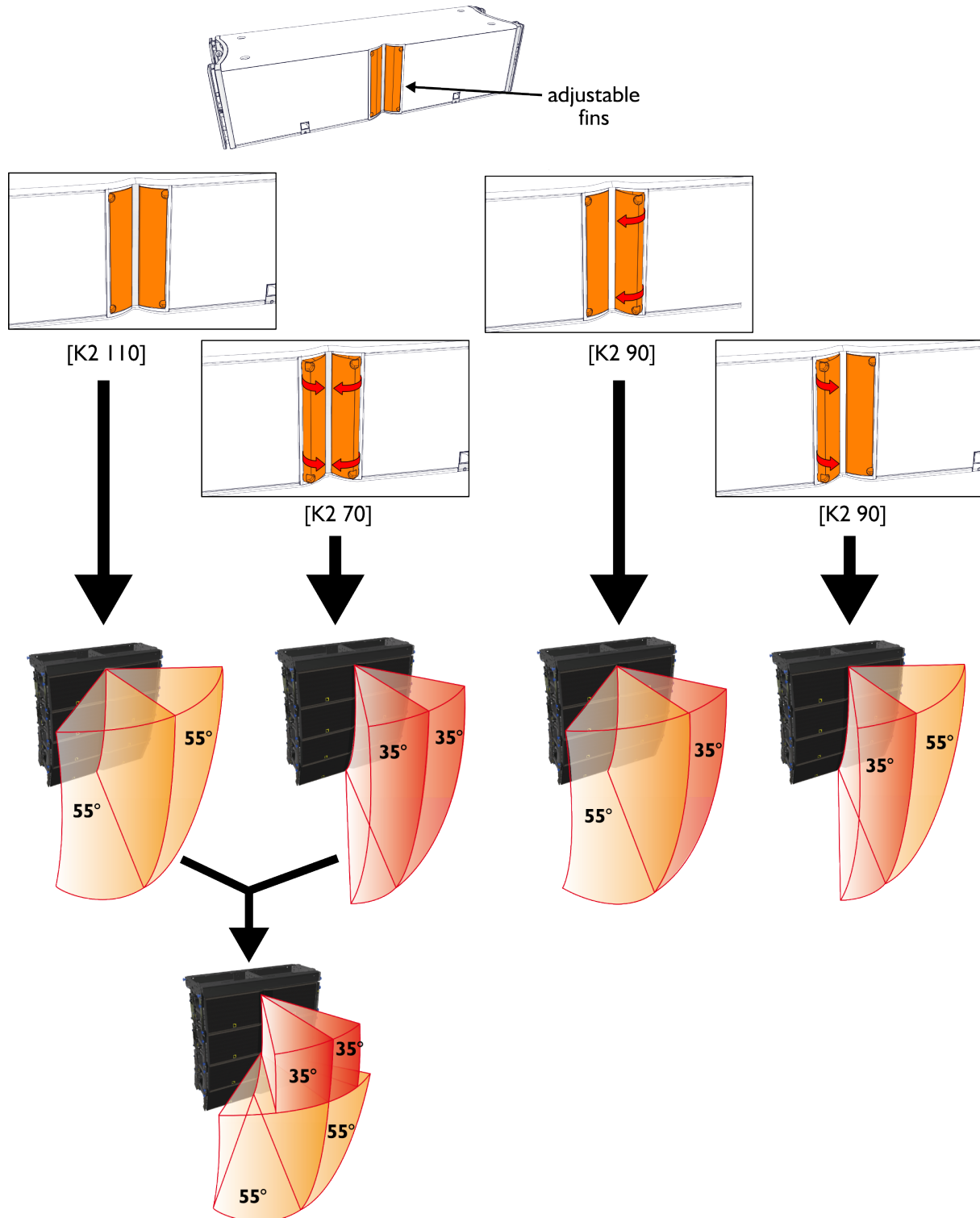

K2 directivity

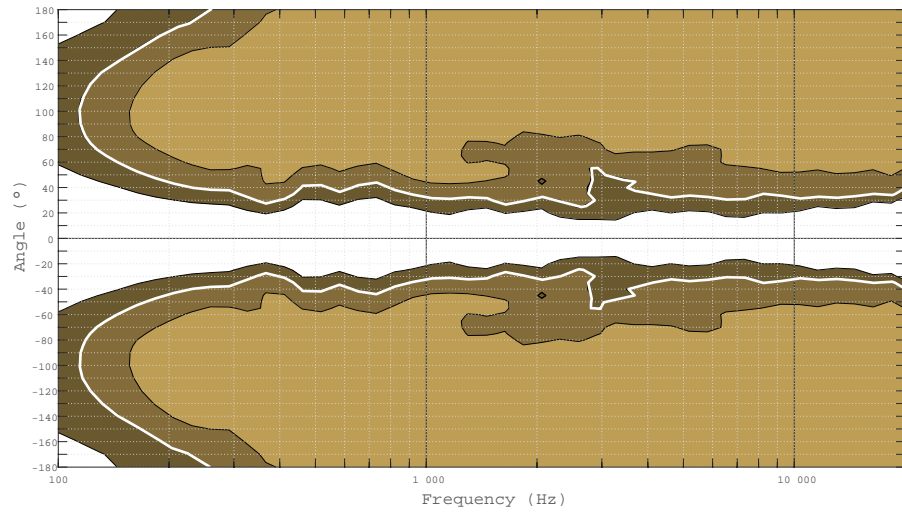
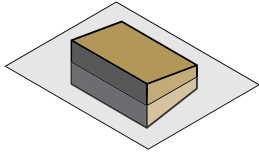

Dispersion angle diagram of a K2 array with 70° fins setting, using lines of equal sound pressure at -3 dB, -6 dB, -12 dB.

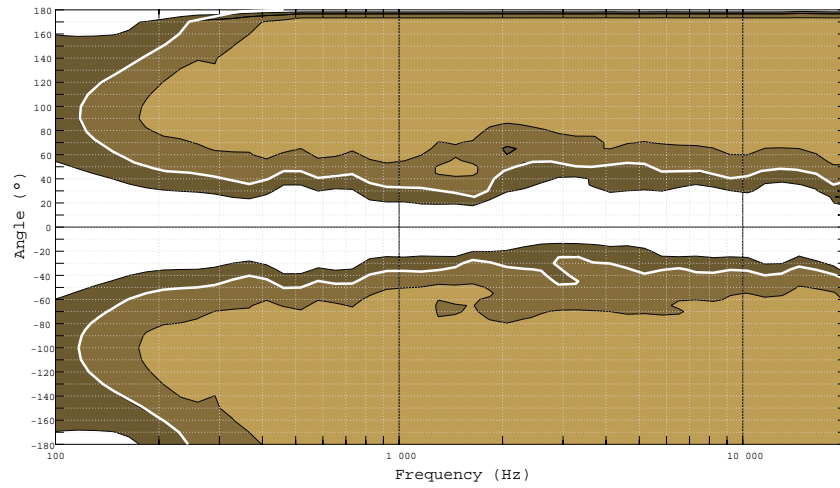
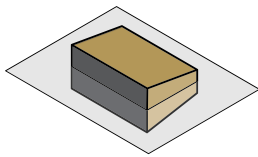

Dispersion angle diagram of a K2 array with 90° fins setting, using lines of equal sound pressure at -3 dB, -6 dB, -12 dB.

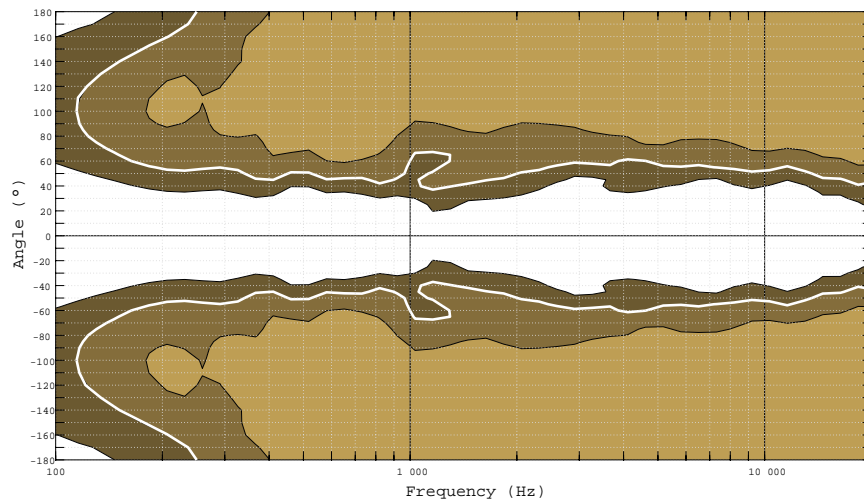
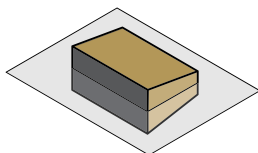

Dispersion angle diagram of a K2 array with 110° fins setting, using lines of equal sound pressure at -3 dB, -6 dB, -12 dB.

K1-SB applications

There are two distinct applications for K1-SB in a K2 system:

- As an LF extension in a line source for enhanced throw, using the [K1SB_X K2] preset with K2.
- As a subwoofer for increased impact, using the [K1SB_60] preset.

i Both applications of K1-SB can be combined in the same configuration.

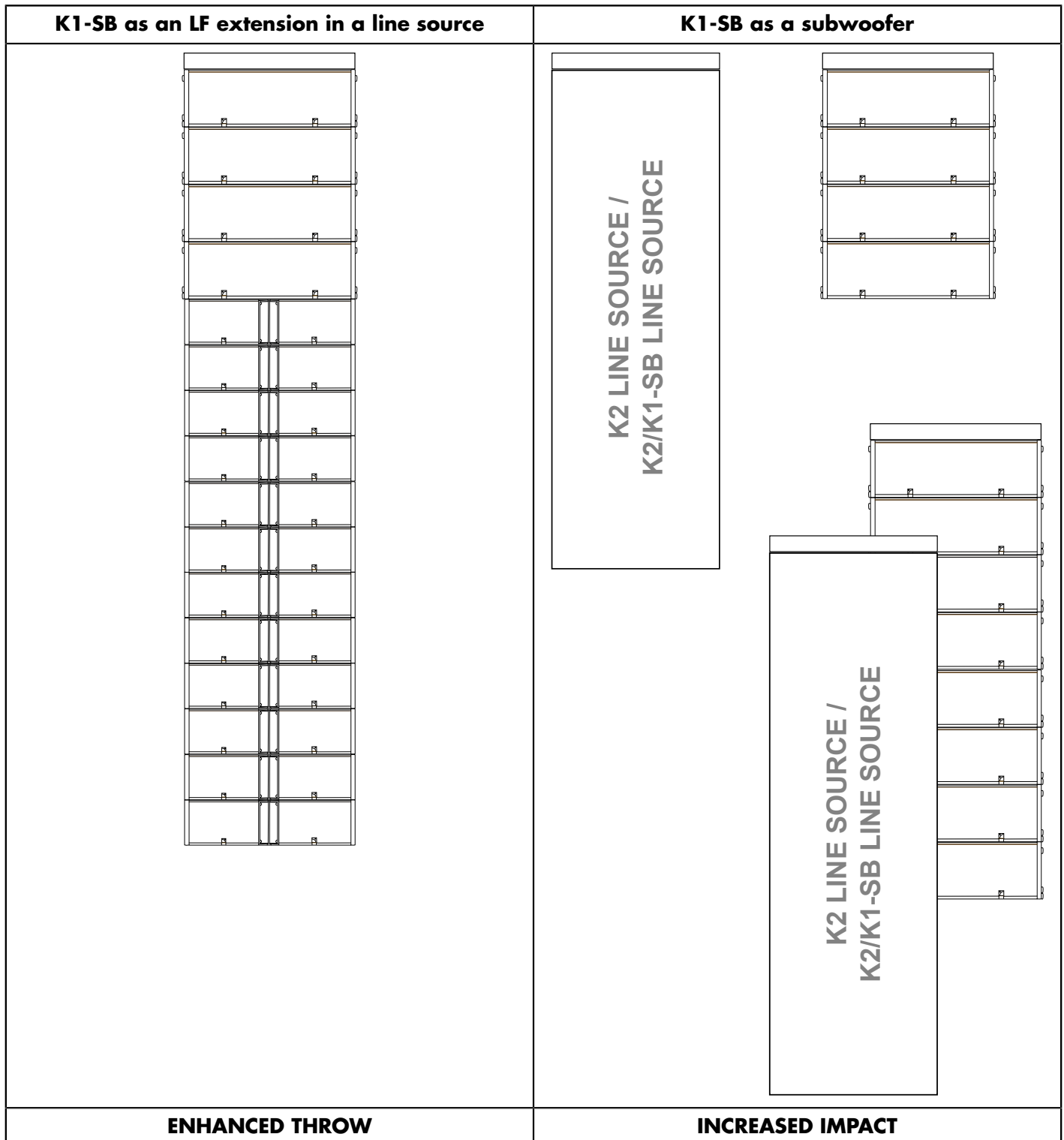

Preset description

[K2 70] [K2 90] [K2 110]

loudspeaker elements	outputs	channels	routing	gain	delay	polarity	mute
left LF	OUT 1	LF	IN A	0 dB	0 ms	+	ON
right LF	OUT 2	LF					ON
MF	OUT 3	MF					ON
HF	OUT 4	HF					ON

[KARAIIDOWNK2]

loudspeaker elements	outputs	channels	routing	gain	delay	polarity	mute
LF	OUT 1	LF	IN A	0 dB	0 ms	+	ON
HF	OUT 2	HF					ON
LF	OUT 3	LF	IN A	0 dB	0 ms	+	ON
HF	OUT 4	HF					ON

[K1SB_60] [K1SB_X K2] [KS28_60] [SB28_60]

outputs	channels	routing	gain	delay	polarity	mute
OUT 1	SB	IN A	0 dB	0 ms	+	ON
OUT 2	SB	IN A	0 dB	0 ms	+	ON
OUT 3	SB	IN A	0 dB	0 ms	+	ON
OUT 4	SB	IN A	0 dB	0 ms	+	ON

[KS28_60_C] [SB28_60_C]

loudspeaker elements	outputs	channels	routing	gain	delay	polarity	mute
SR	OUT 1	SR	IN A	0 dB	0 ms	+	ON
SB	OUT 2	SB					ON
SB	OUT 3	SB					ON
SB	OUT 4	SB					ON

Connectors



SpeakON connectors can be used interchangeably as IN or LINK connector.

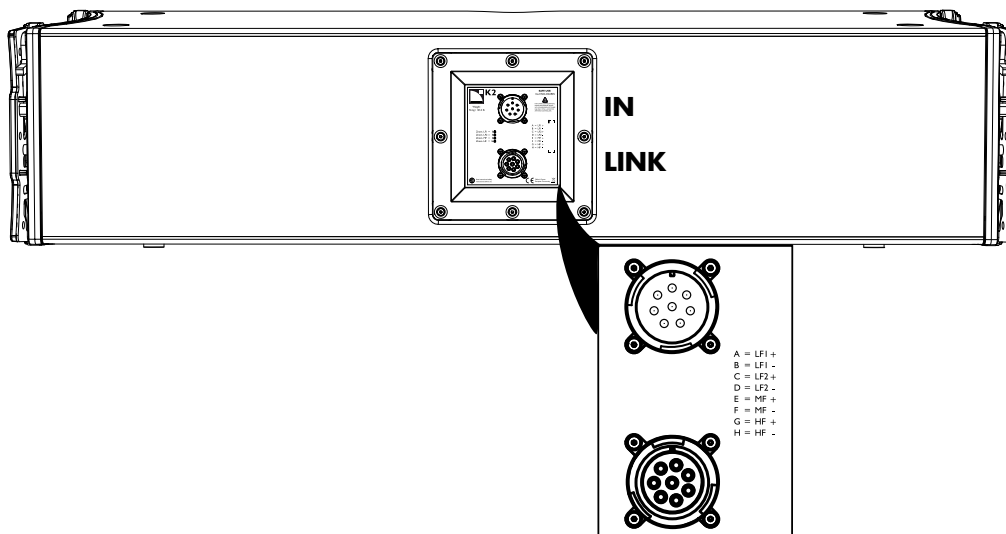

K2

2 × 8-point PA-COM

Internal pinout for L-Acoustics 3-way active enclosures

PA-COM points	A/B	C/D	E/F	G/H
Transducer connectors	left LF	right LF	MF	HF

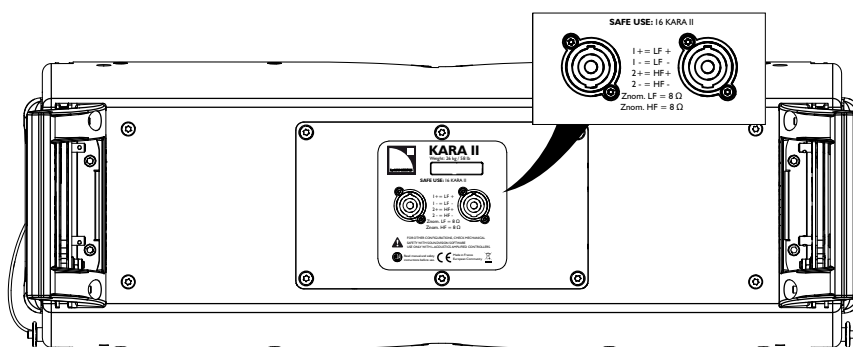

Kara II

2 × 4-point speakON

Internal pinout for L-Acoustics 2-way active enclosures

speakON points	1 +	1 -	2 +	2 -
Transducer connectors	LF +	LF -	HF +	HF -

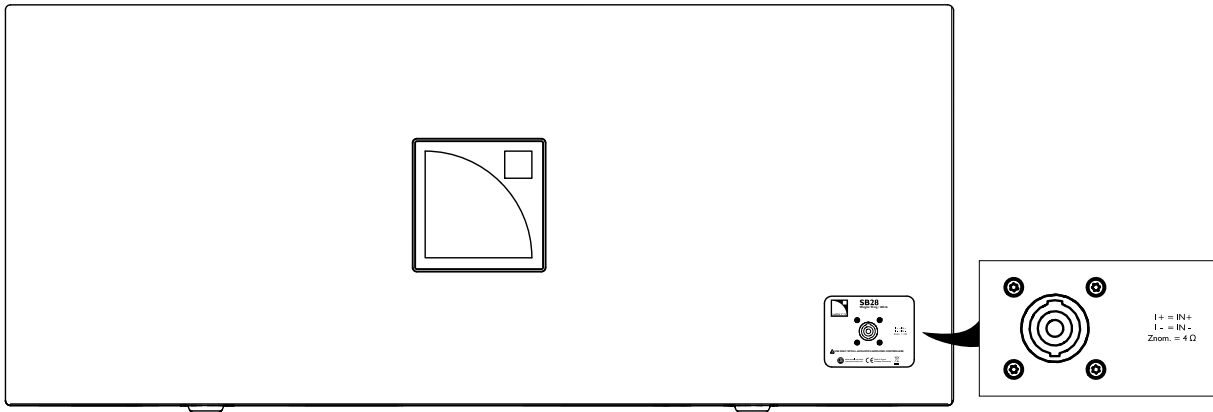

SB28

1 x 4-point speakON

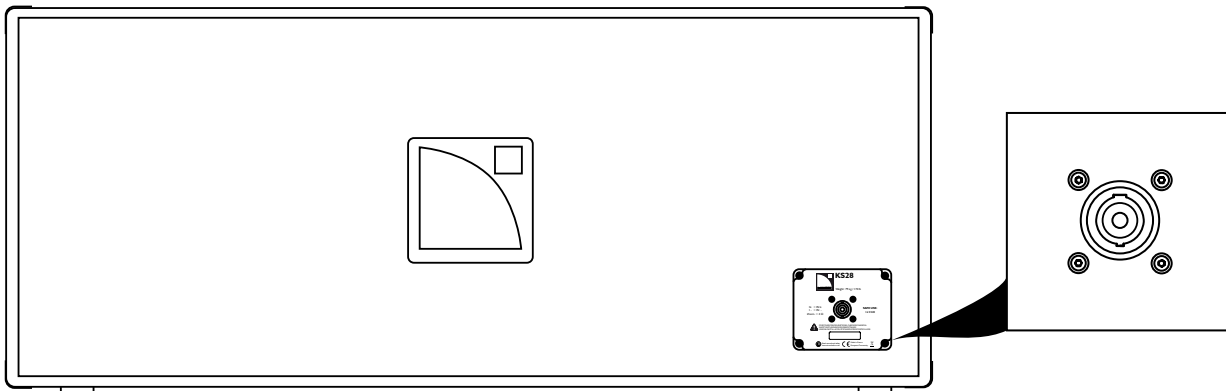

KS28

1 x 4-point speakON

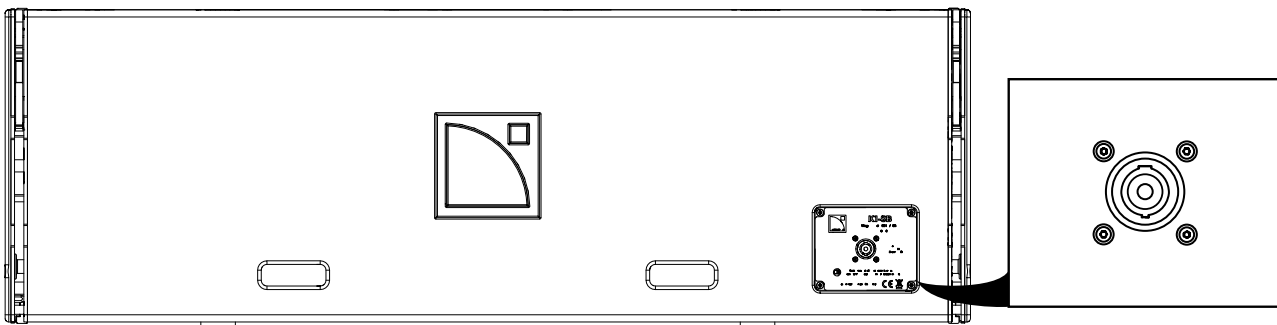

K1-SB

1 x 4-point speakON

Internal pinout for L-Acoustics subwoofers

speakON points	1 +	1 -	2 +	2 -
Transducer connectors	LF +	LF -	Not linked	Not linked

Rigging system description

Elements for enclosure rigging

K2

On both sides, K2 integrates two arms to connect another element of the rigging system, such as an enclosure or to a flying frame.

- At the front, a rotating arm provides a fixed point around which the enclosure can freely rotate until its connection at the rear.
- At the rear, a sliding arm enables the inter-element angle setting and the inter-element rear connection.

The angles between adjacent enclosures are secured by an automatic system that is activated in advance and locks itself during the stacking and lifting procedures.

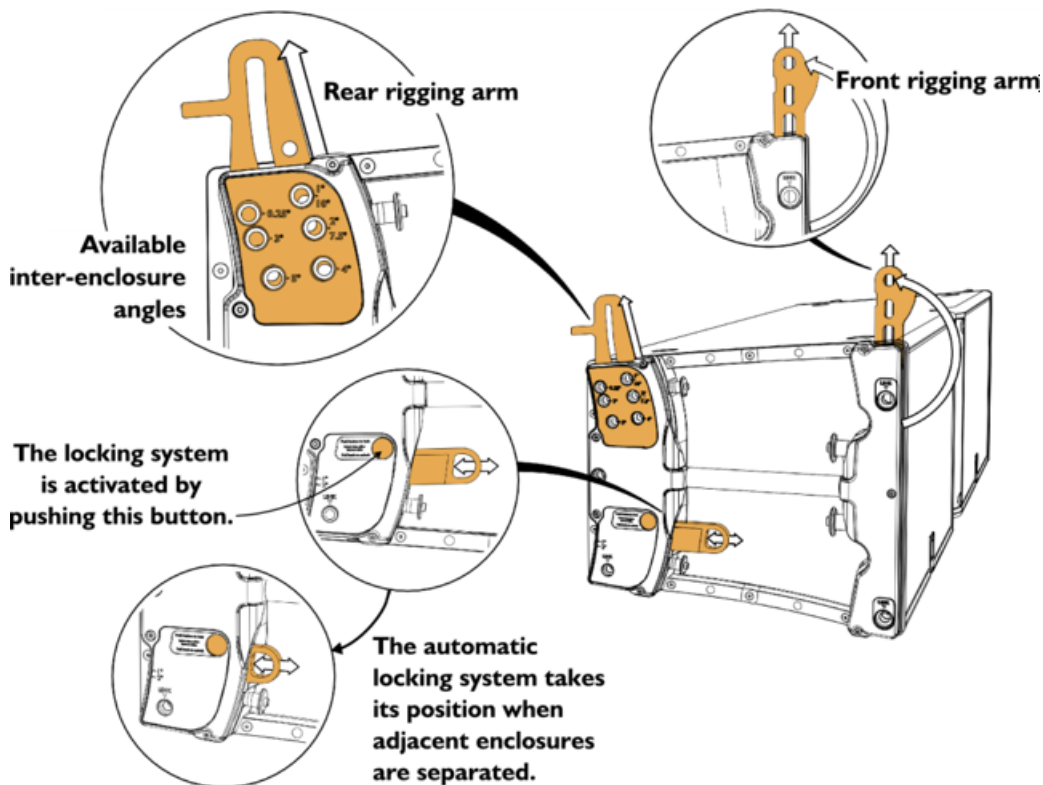

Elements for storage and transportation

K2-CHARIOT

K2-CHARIOT is designed for the transportation and storage of blocks of four K2 enclosures.

During transportation the blocks must have an inter-enclosure angle of 10° to avoid any separation of the enclosures. This angle must be set using the enclosure rear rigging arm pin. The automatic locking system must remain unloaded.

The K2-CHARIOT rear rigging arm must be at its -15° site angle position.

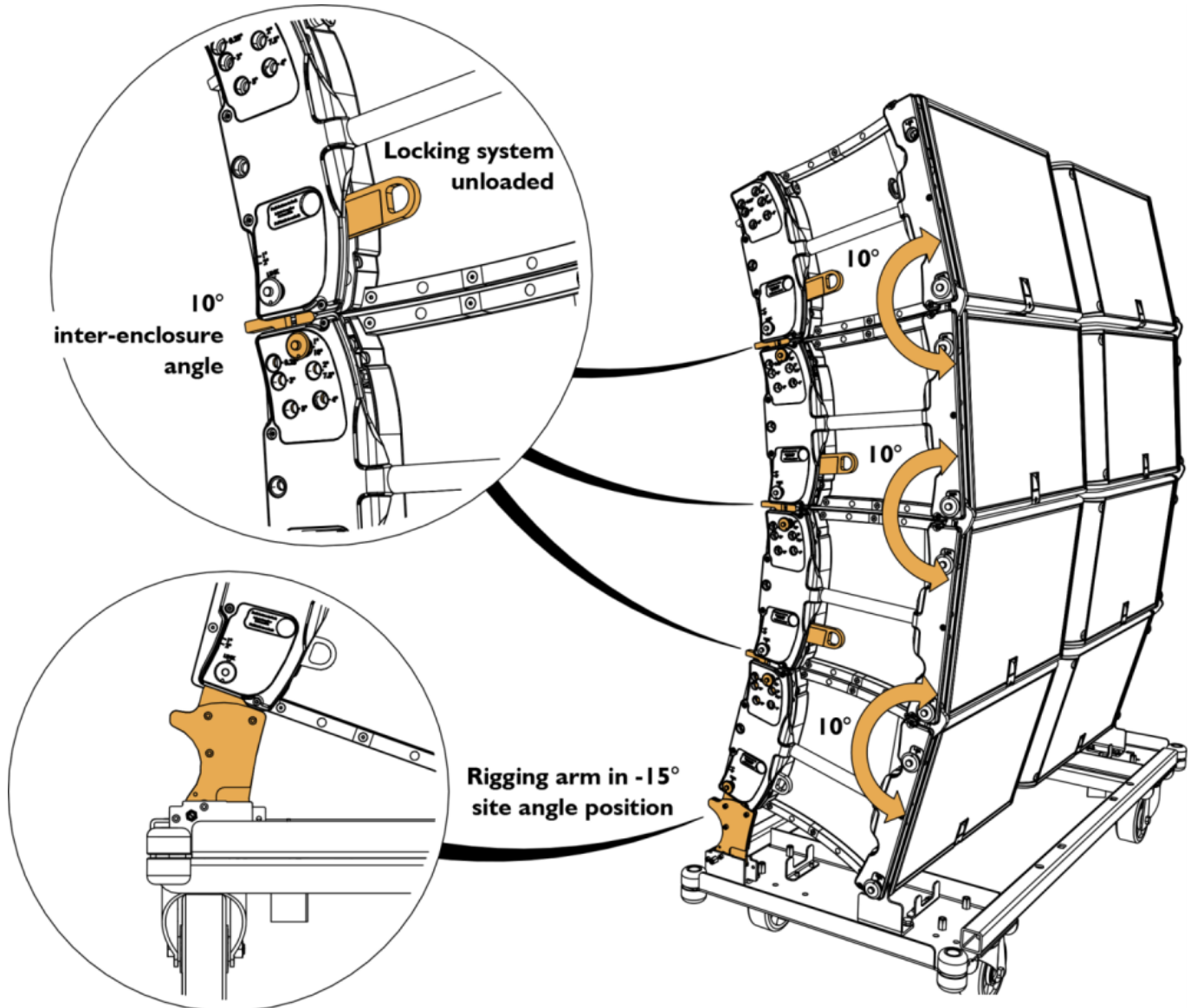

Tipping hazard

If the enclosures are not pinned at 10° , they can separate at the back and cause the stack to tip over.

Elements for ground stacking

K2-CHARIOT with K2-JACK

The K2-CHARIOT, combined with two K2-JACK stabilizers, is used as a stacking platform for K2 enclosures.

Tipping hazard

Always install the K2-JACK before:

- setting the inter-enclosure angles
- changing the position of the K2-CHARIOT rear rigging arms

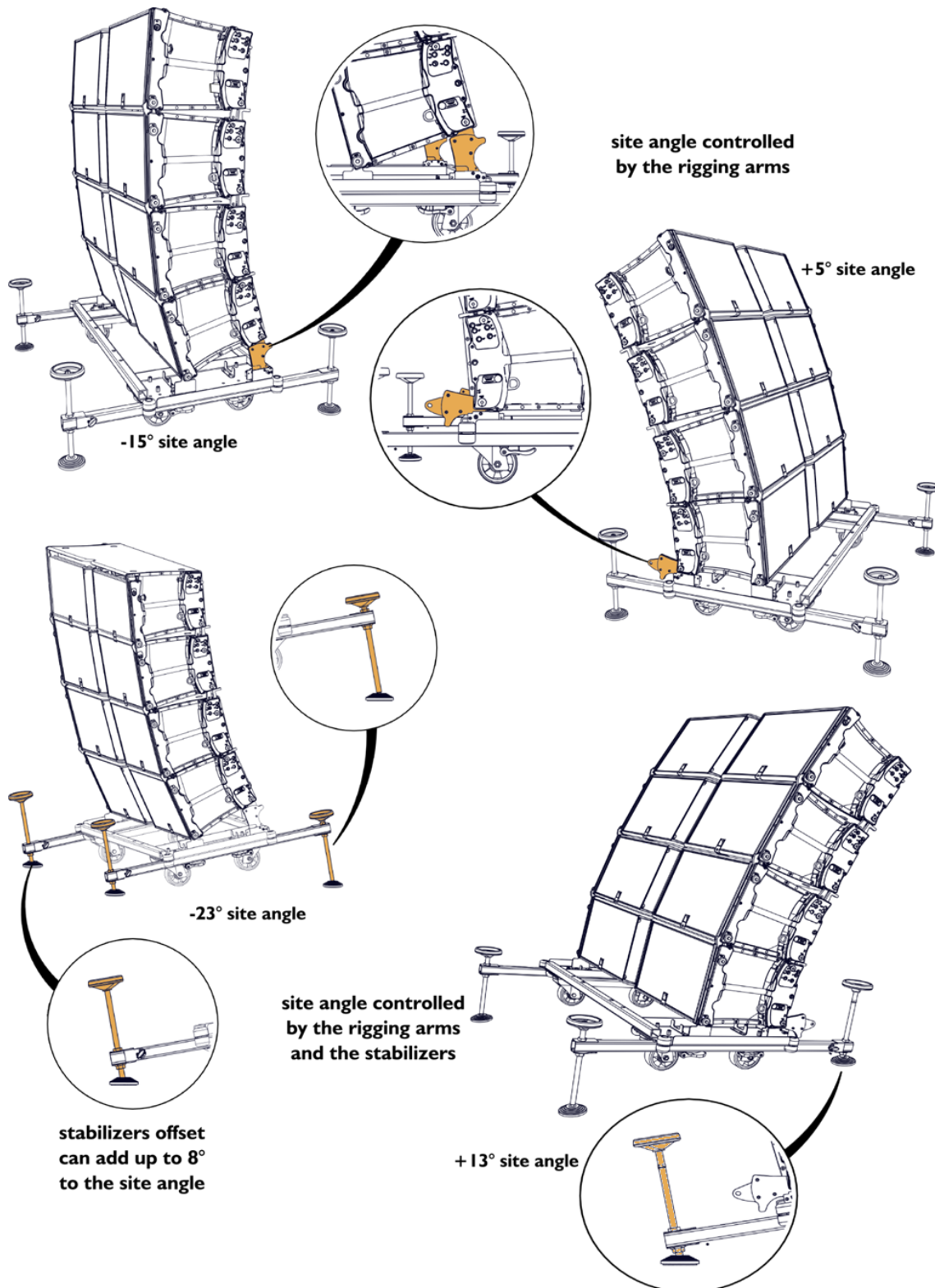

Elements for flying

K2-BUMP

K2-BUMP is designed for flying line arrays of K2, K1 or K1-SB. 4 holes are available on the central bar of the K2-BUMP. Refer to your Soundvision model to know which holes to use.

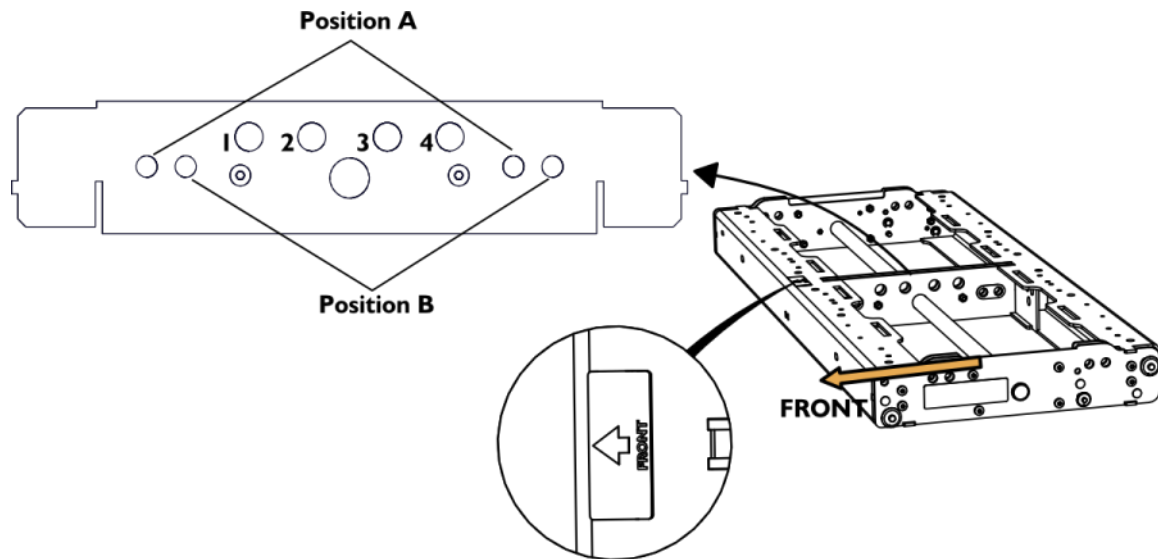

With K1-SB and a single motor the hole n°2 provides a 0° site angle.

K2-BAR to K2-BUMP

By adding a K2-BAR to the K2-BUMP, the site angle range can be increased. 21 holes are available on the K2-BAR which can be attached to the K2-BUMP as a rear or a front extension and in position A or B, thus offering a total of 84 discrete positions for pick-up points.

The rear extension is suited to downwards and front extension to upwards site angles.

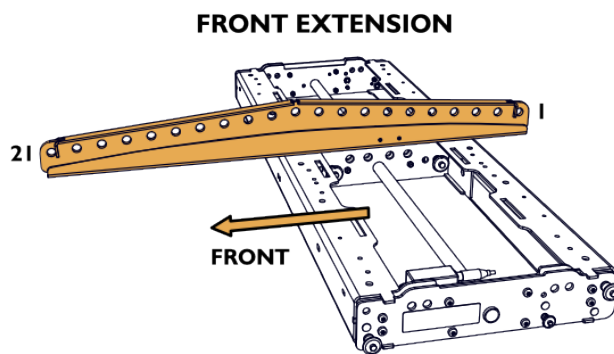
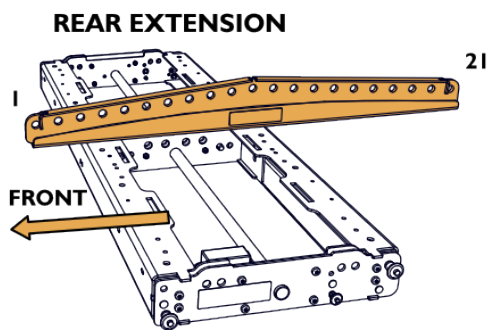
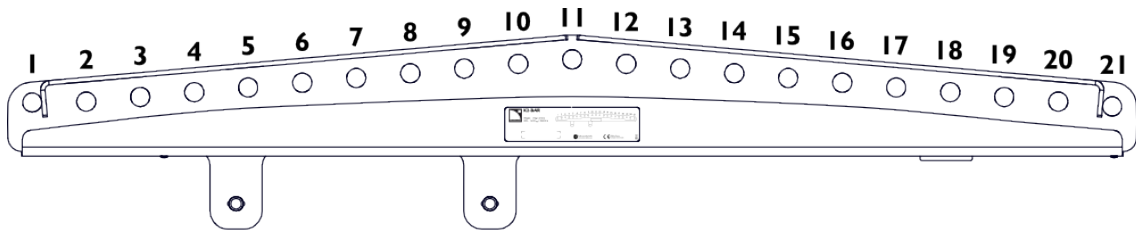

Standard: One K2-BAR attached in the center of K2-BUMP

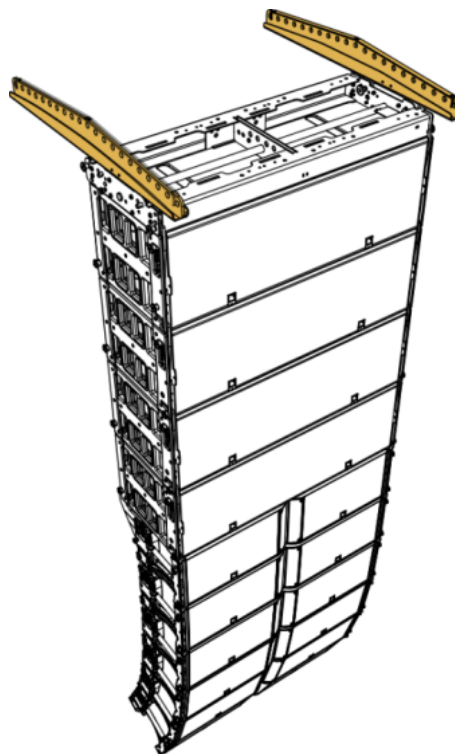

Alternative: Two K2-BAR attached on the sides

K2-LINK

The K2-LINK is designed as an interface between the K1 and K2 rigging systems.

It is used to hang K2 under K1, K1-SB or K1-BUMP.

It provides three holes and therefore three angles between the top K2 enclosure and the bottom K1 element: 0.25°, 2.5° and 5°.

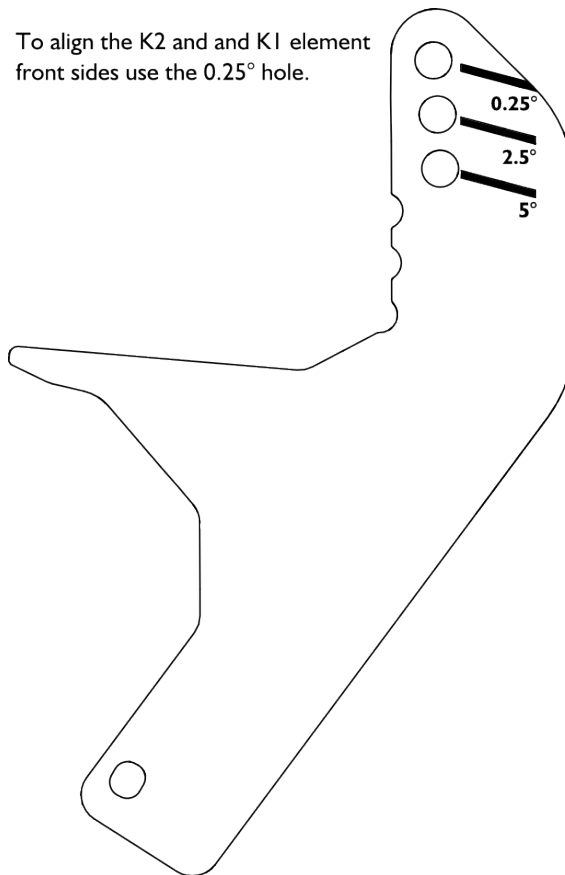

K2-RIGBAR

The K2-RIGBAR can be used to implement a pullback either with K2-BUMP / K2-BAR or another K2-RIGBAR. It must be used with the LA-SLING2T.

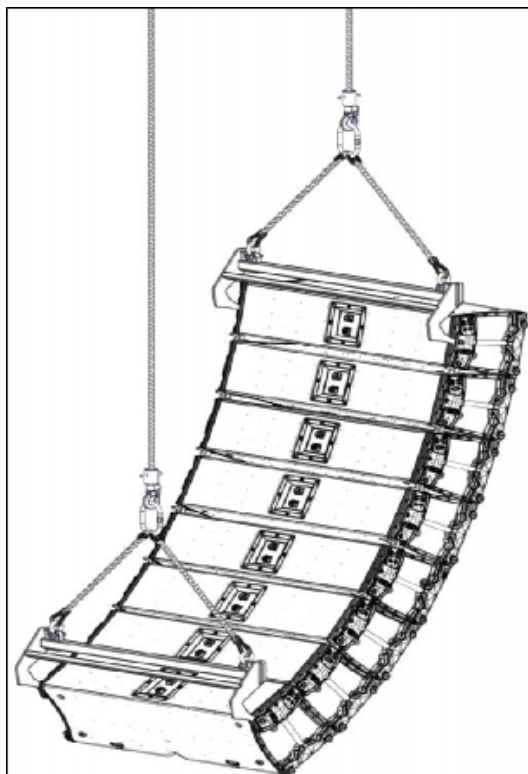

The K2-RIGBAR can also be used as the main lifting point, thus providing a lighter solution for flying K2 enclosures with one lifting point.

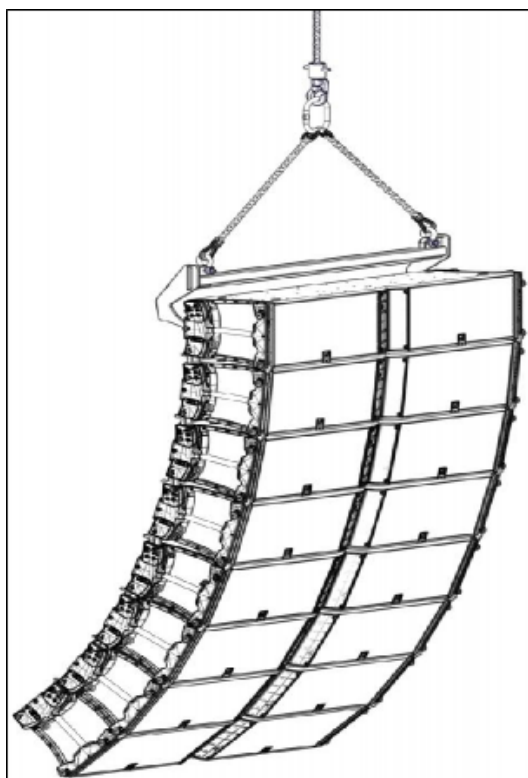

i Refer to [N - Using a K2-RIGBAR to implement a pullback](#) (p.120) for more information on how to implement a pullback.

KARADOWNK2

KARADOWNK2 is a rigging interface for Kara II under a K2 array.

The four tabs on the top are compatible with the K2 rigging system.

The four slits fitted with ball-locking pins accommodate the Kara II rigging arms.

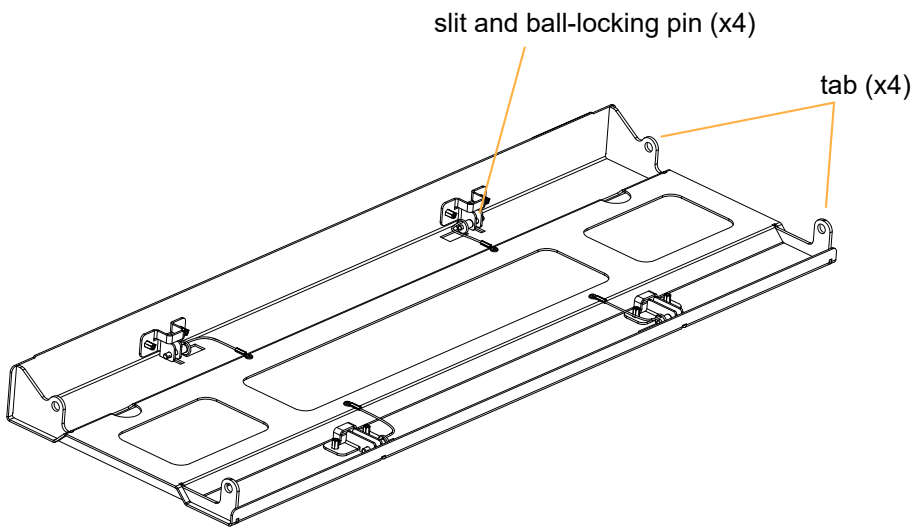

Elements for LA-RAK/LA-RAK II rigging

K2-RAKMOUNT

The K2-RAKMOUNT is designed to stack one or two LA-RAK/LA-RAK II on top of a flown array. It is composed of four rails and a stabilizer.

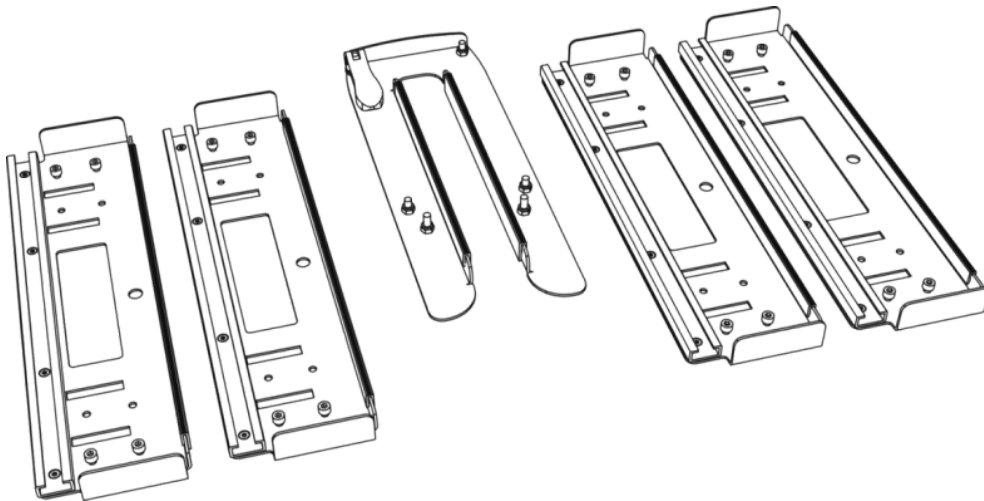

The rails are screwed on the K2-BUMP. Their number and position depend on the number of racks. The K2-RAKMOUNT must be used along with either one or two K2-BAR.

1 LA-RAK/LA-RAK II : 2 rails : 2 K2-BAR

2 LA-RAK/LA-RAK II : 4 rails : 1 K2-BAR

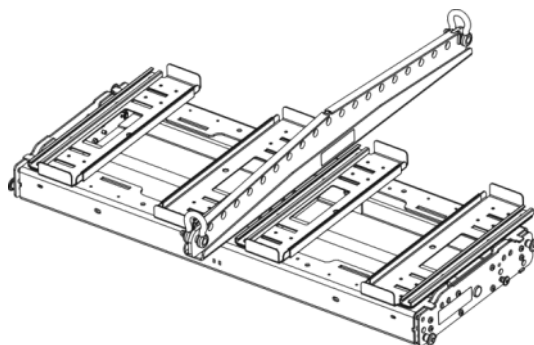
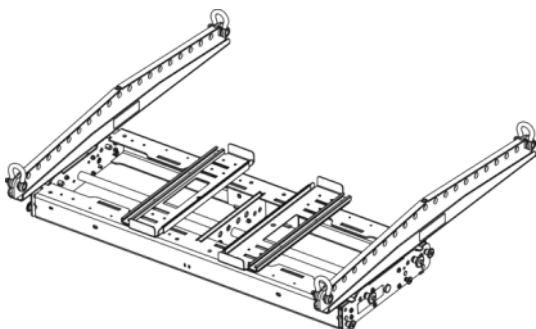
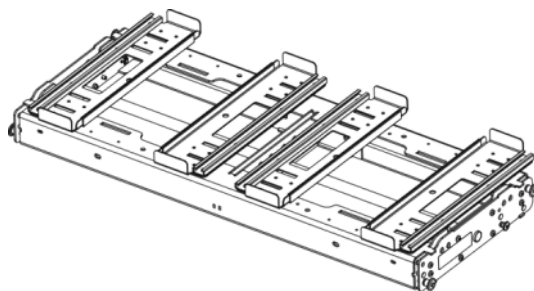
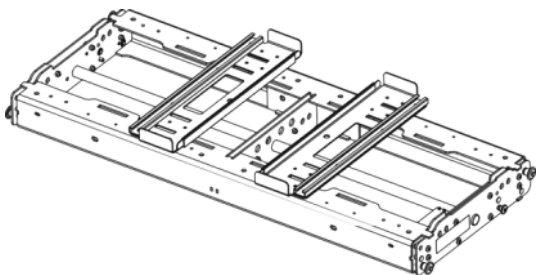

When two racks are mounted side by side, the stabilizer is used to prevent the assembly from tipping or toppling over. The stabilizer traps one of the chains used to lift the assembly.

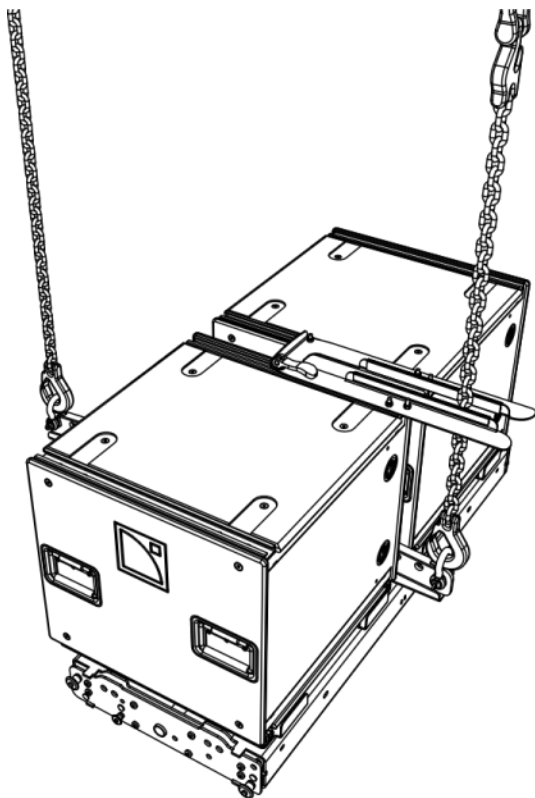

0° site angle

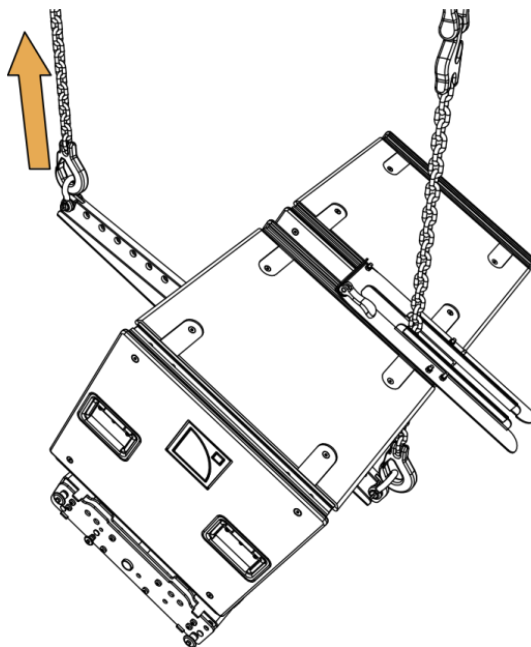

30° positive site angle

Mechanical safety

Flown configurations

The K2 rigging system complies with 2006/42/EC: Machinery Directive. It has been designed following the guidelines of BGV-C1.

2006/42/EC: Machinery Directive specifies a safety factor of 4 against the rupture. The flown deployments described in this manual achieve a safety factor of **4 or more**.

Refer to Soundvision for the safety factor of a specific deployment.

The **safe limit** gives the maximum number of elements for which the safety factor is compliant with the 2006/42/EC: Machinery Directive, within the use defined in this manual and regardless of the other deployment parameters (site angles, inter-enclosure angles, etc.).

The **maximum limit** gives the maximum number of elements for which the safety factor can be compliant with the 2006/42/EC: Machinery Directive, when the other deployment parameters provide the best mechanical conditions.

For mixed arrays refer to your Soundvision model.

 **Always refer to Soundvision for the safety factor of a mixed array.**
When flying a K2 array with a Kara II downfill, the mechanical safety of all system elements must be considered. The indicated maximum limit applies to the K2 only.

 **Do not implement a pullback on a K2 array with a Kara II downfill.**

K2

configuration	rigging accessory	safe limit	maximum limit
flown	K2-BUMP	16	24
	K2-BUMP + K2-BAR	14 K2 + 2 LA-RAK	24 K2 + 2 LA-RAK
		12 K1-SB + 1 LA-RAK	16 K1-SB + 2 LA-RAK
		10 K1 + 2 LA-RAK	12 K1 + 2 LA-RAK
	K2-LINK under K1-BUMP	16	24
K2-RIGBAR	12	12	
flown with a downfill	KARADOWNK2	6 Kara II	

K1-SB

configuration	rigging accessory	safe limit	max limit
flown	K1-BUMP	18	24

KS28

configuration	rigging accessory	maximum / safe limit
flown	KS28-BUMP	16

SB28

configuration	rigging accessory	maximum / safe limit
ground-stacked	No rigging accessory	4
flown	BUMPSUB	8
flown	BUMPSUB-2 + SB28CHAIN	16

Other configurations

For other configurations, respect the recommended maximum limit for optimal stability.

K2

configuration	rigging accessory	safe limit	maximum limit
ground-stacked	K2-BUMP	4	6
stacked	K2-CHARIOT with K2-JACK	4	6

KS28

Configuration	Rigging accessory	Maximum limit
ground-stacked	no rigging accessory	4
stacked upright	no rigging accessory	2
stacked on chariot	KS28-CHARIOT	4

Assessing mechanical safety

-  **Mechanical safety of the rigging system**
 Before any installation, always model the system in Soundvision and check the **Mechanical Data** section for any stress warning or stability warning.

In order to assess the actual safety of any array configuration before implementation, refer to the following warnings:

-  **Rated working load limit (WLL) is not enough**
 The rated WLL is an indication of the element resistance to tensile stress. For complex mechanical systems such as loudspeaker arrays, WLLs cannot be used per se to determine the maximum number of enclosures within an array or to assess the safety of a specific array configuration.

Maximum pullback angle

If a pullback accessory is available, the pullback angle must not exceed a 90° negative site angle.

Mechanical modeling with Soundvision

The working load applied to each linking point, along with the corresponding safety factor, will depend on numerous variables linked to the composition of the array (type and number of enclosures, splay angles) and the implementation of the flying or stacking structure (number and location of flying points, site angle). This cannot be determined without the complex mechanical modeling and calculation offered by Soundvision.

Assessing the safety with Soundvision

The overall safety factor of a specific mechanical configuration always corresponds to the lowest safety factor among all the linking points. Always model the system configuration with the Soundvision software and check the **Mechanical Data** section to identify the weakest link and its corresponding working load. By default, a stress warning will appear when the mechanical safety goes beyond the recommended safety level.

Safety of ground-stacked arrays in Soundvision

For ground-stacked arrays, a distinct stability warning is implemented in Soundvision. It indicates a tipping hazard when the array is not secured to the ground, stage or platform. It is the user's responsibility to secure the array and to ignore the warning.

Additional safety for flown arrays

When flying an array, use available holes to implement a secondary safety.

Considerations must be given to unusual conditions

Soundvision calculations are based on usual environmental conditions. A higher safety factor is recommended with factors such as extreme high or low temperatures, strong wind, prolonged exposition to salt water, etc. Always consult a rigging specialist to adopt safety practices adapted to such a situation.

Loudspeaker configurations

K2 line source

Deployed as a line source, the system operates over the nominal bandwidth of the K2 enclosure, with an adjustable horizontal directivity.

Two configurations are possible:

- K2 line source
- K2/K1-SB line source: enhanced LF throw

The [K2 70], [K2 90] and [K2 110] presets allow for a reference frequency response in long throw applications. Each preset is dedicated to a horizontal directivity setting.

By providing the K1-SB with the same frequency response as the K2 low section, the [K1SB_X K2] preset allows the K1-SB enclosure to be used as an LF line source element, increasing the length of the sub-low line source.

Amplified controllers compatibility

	LA4X	LA8	LA12X
K2	✓	✓	✓
K1-SB	-	✓	✓
KS28	-	-	✓
SB28	-	✓	✓

Standalone K2 line source

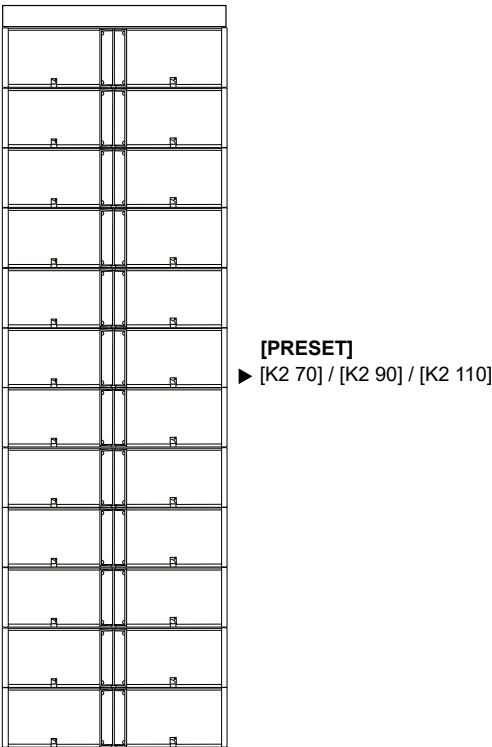
	
Enclosure	K2
Preset	[K2 70] [K2 90] [K2 110]
Frequency range (-10 dB)	35 Hz - 20 kHz

K2/K1-SB line source

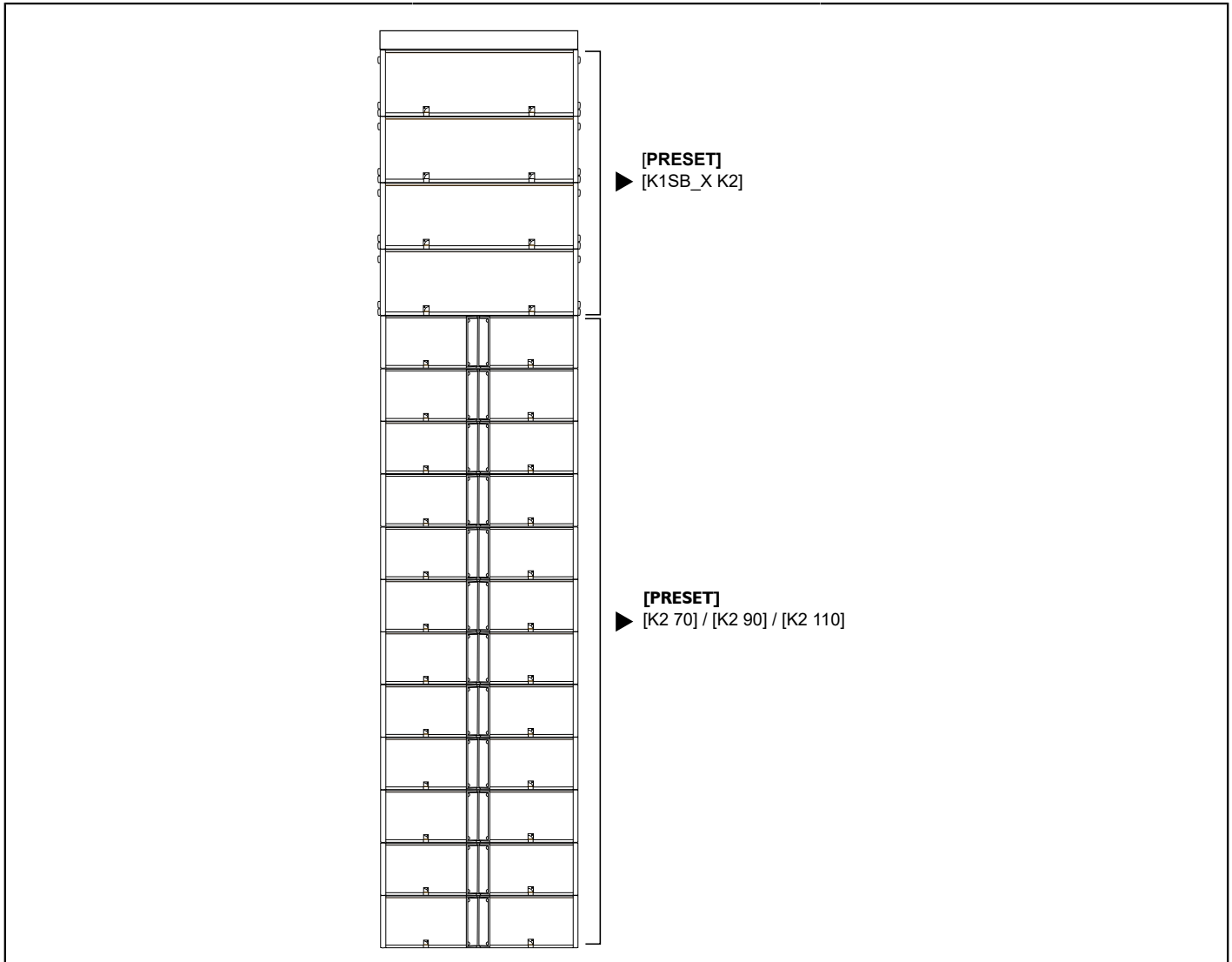

Enclosure	K2	K1-SB
Preset	[K2 70] [K2 90] [K2 110]	[K1SB_X K2]
Frequency range (-10 dB)	35 Hz - 20 kHz	
Recommended ratio	3 K2 : 1 K1-SB	
Minimum line length	12 K2 + 4 K1-SB	

! When using [K2 70], [K2 90], or [K2 110] with [K1SB_X K2], do not add any delay value between the K2 and K1-SB elements of a same line source.

Additional subwoofer system

A K2 line source or a K2/K1-SB line source can be deployed with additional subwoofer enclosures to provide increased sub-low resources to demanding applications.

Two subwoofer systems are available:

- K1-SB for increased LF contour
- KS28 or SB28 for infra extension

The recommended ratio is 3 K2 for 2 subwoofers, whether using K1-SB subwoofers only, KS28 or SB28 subwoofers only, or a combination of both.

The [K1SB_60], [KS28_60], and [SB28_60] presets provide the subwoofers with an upper frequency limit at 60 Hz for an optimal frequency coupling with the line source.

Amplified controllers compatibility

	LA4X	LA8	LA12X
K2	✓	✓	✓
K1-SB	-	✓	✓
KS28	-	-	✓
SB28	-	✓	✓

K1-SB

The K1-SB provides an extension of the bandwidth in the low end, down to 30 Hz. Depending on the deployment, LF rejection can be produced.

Three deployments are available in this configuration:

- K1-SB on top of the K2 line source
- K1-SB beside the K2 or K2/K1-SB line source : side LF rejection (polarized)
- K1-SB behind the K2 or K2/K1-SB line source : rear LF rejection (cardioid)

Pre-alignment delays

presets	pre-alignment delay values and polarity settings	
[K2] + [K1SB_X K2]	K2 = 0 ms <input style="float: right;" type="button" value="+"/>	K1-SB = 0 ms <input style="float: right;" type="button" value="+"/>
[K2] + [K1SB_60]	K2 = 6 ms <input style="float: right;" type="button" value="+"/>	K1-SB = 0 ms <input style="float: right;" type="button" value="+"/>

Line source with K1-SB on top

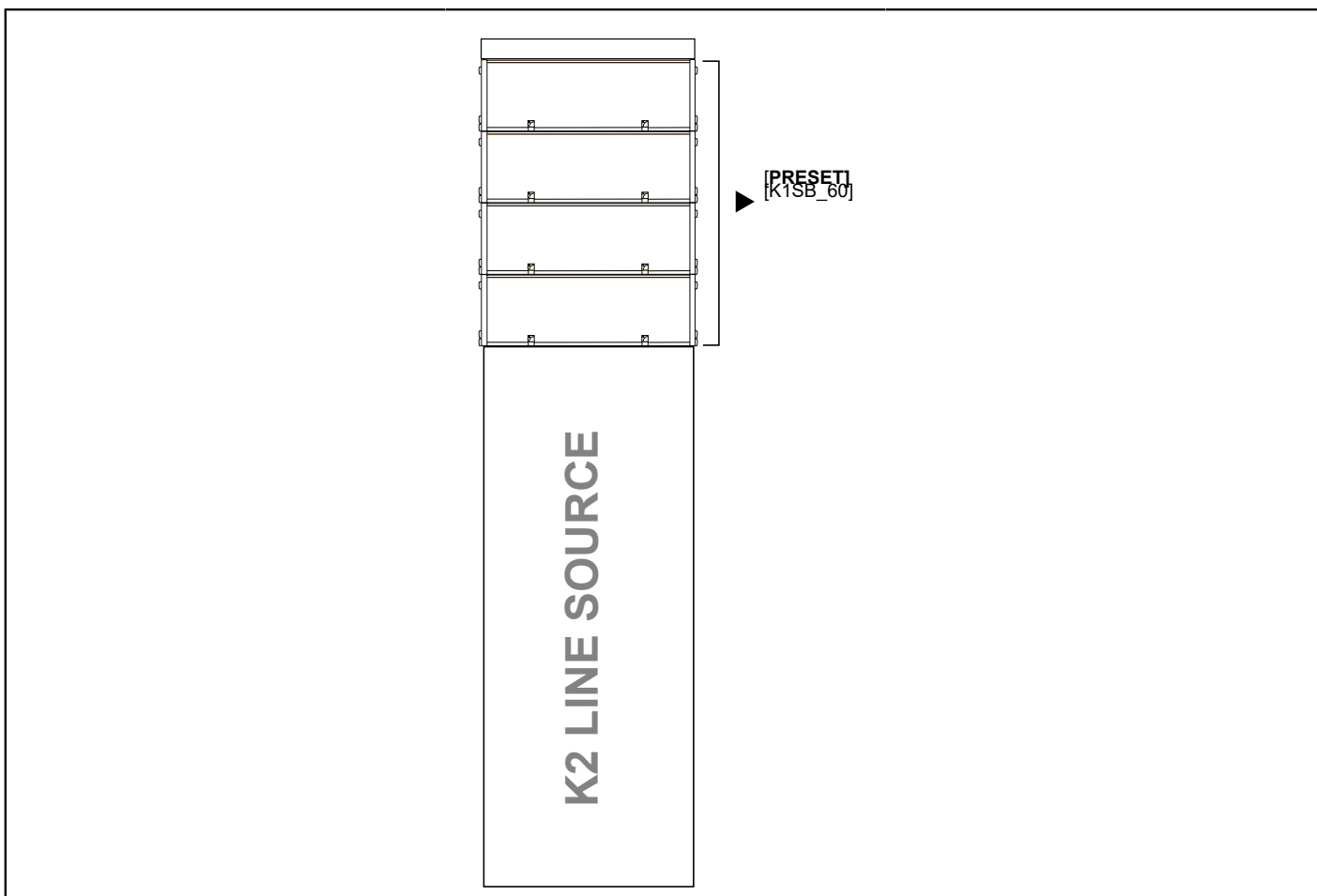

Enclosure	K2	K1-SB as subwoofer
Preset	[K2 70][K2 90][K2 110]	[K1SB_60]
Frequency range (-10 dB)	30 Hz - 20 kHz	
Recommended ratio	3 K2 : 2 subwoofers	
Maximum number line length	12 K2 + 8 K1-SB	



Delay values

Do not forget to add the pre-alignment and geometric delays depending on the configuration.

Line source with K1-SB beside

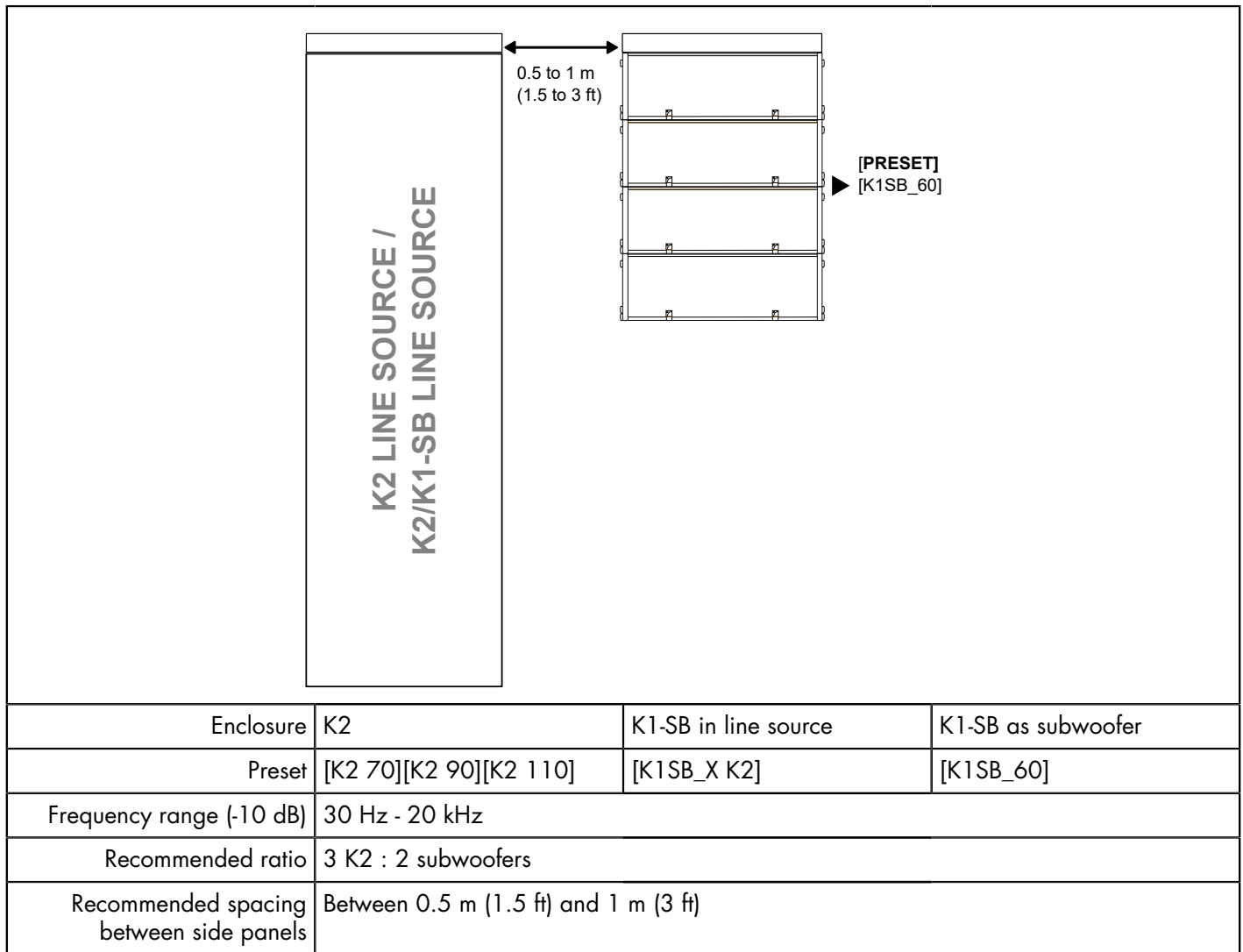

- ! Delay values**
- Do not forget to add the pre-alignment and geometric delays depending on the configuration.
 - When using [K2 70], [K2 90], or [K2 110] with [K1SB_X K2], do not add any delay value between the K2 and K1-SB elements of a same line source.

Line source with K1-SB behind

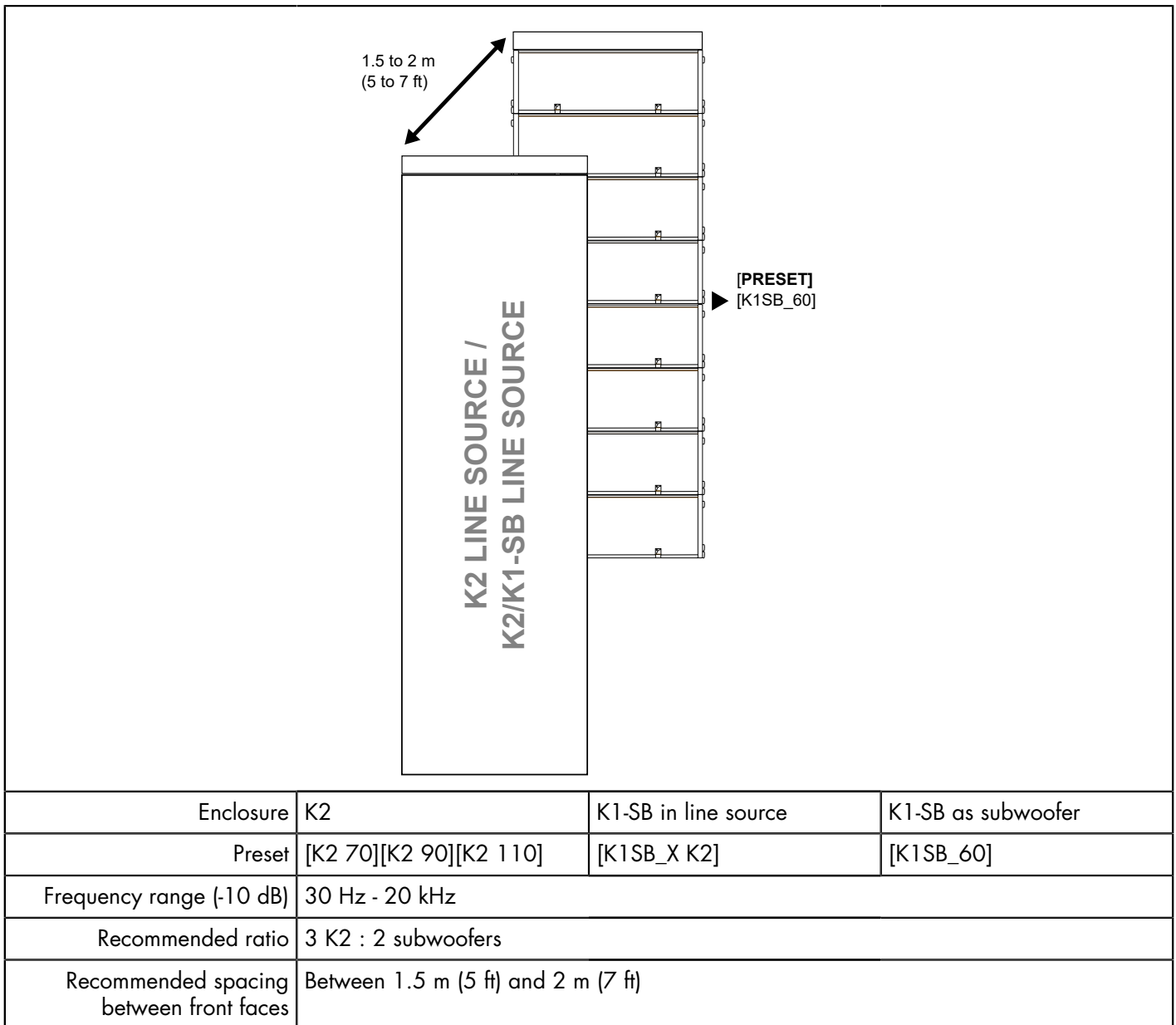

! Delay values

Do not forget to add the pre-alignment and geometric delays depending on the configuration.

! When using [K2 70], [K2 90], or [K2 110] with [K1SB_X K2], do not add any delay value between the K2 and K1-SB elements of a same line source.

Geometric delays

1.5 m (5 ft)	Line source = 4.5 ms
2 m (7 ft)	Line source = 6 ms

KS28

The KS28 provides an extension of the bandwidth in the low end, down to 25 Hz.

Line source with KS28

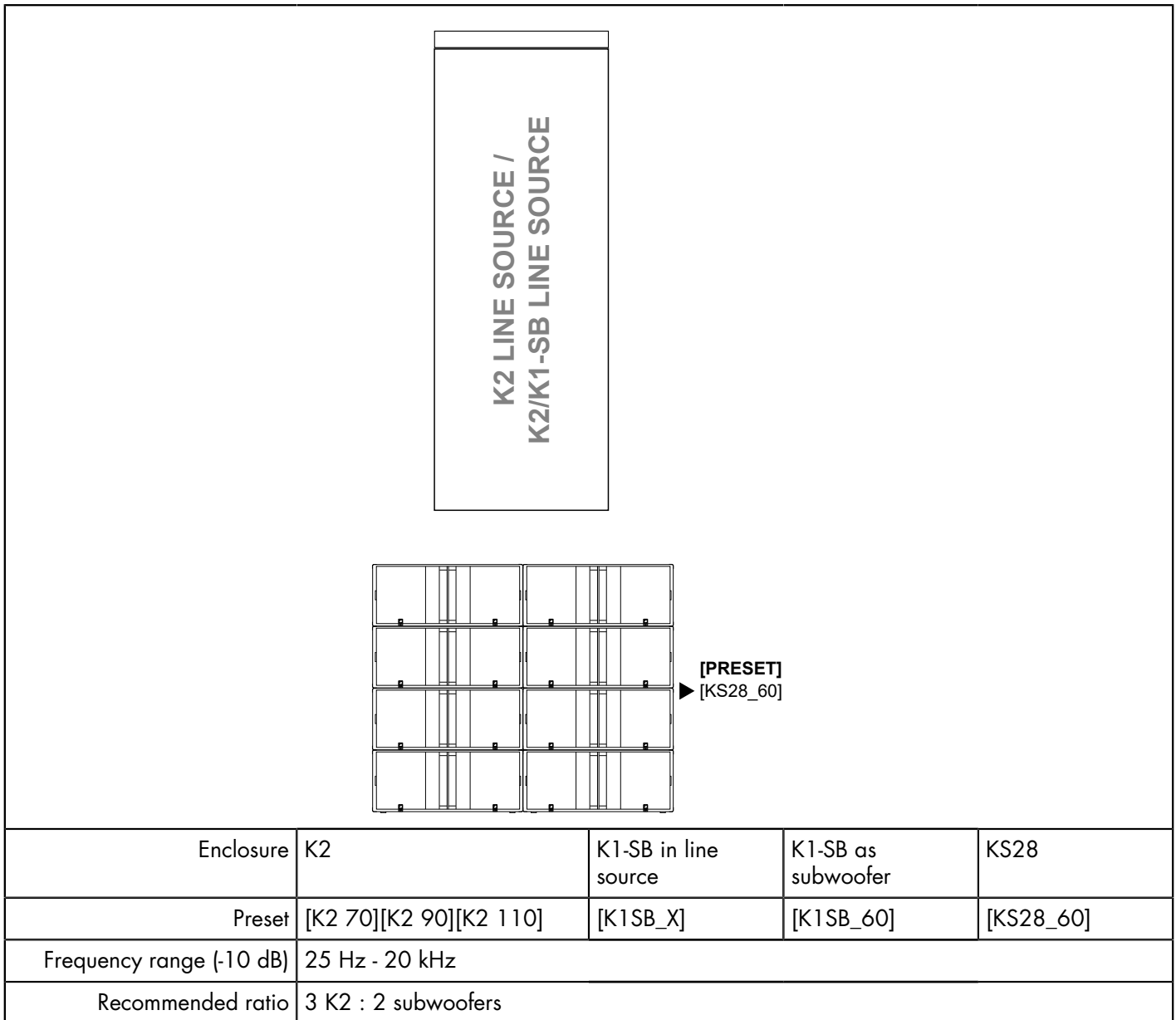

- ! Grouping subwoofers**
Place the subwoofer enclosures side by side. If not possible, the maximum distance between two adjacent acoustic centers must be 2.8 m or 1.7 m if the upper frequency limit of the subwoofer system is at 60 Hz or 100 Hz, respectively.
- ! Use [xxxx_xx_C] or [xxxx_xx_Cx] on a reversed subwoofer in a cardioid configuration**
The cardioid configuration consists in reversing 1 element in an array of 4 subwoofers.
Refer to the subwoofer owner's manual and to the **Cardioid configurations** technical bulletin.
- ! Delay values**
Do not forget to add the pre-alignment and geometric delays depending on the configuration.
- ! When using [K2 70], [K2 90], or [K2 110] with [K1SB_X K2], do not add any delay value between the K2 and K1-SB elements of a same line source.**

Pre-alignment delays**K2 + KS28**

presets	pre-alignment delay values and polarity settings			
[K2] + [KS28_60]	K2 = 0.5 ms	<input type="checkbox"/>	KS28 = 0 ms	<input type="checkbox"/>
[K2] + [KS28_60_C]	K2 = 6 ms	<input type="checkbox"/>	KS28 = 0 ms	<input type="checkbox"/>
[K2] + [KS28_60_Cx]	K2 = 4 ms	<input type="checkbox"/>	KS28 = 0 ms	<input type="checkbox"/>

K2 + K1-SB + KS28

presets	pre-alignment delay values and polarity settings					
[K2] + [K1SB_X K2] + [KS28_60]	K2 = 0 ms	<input type="checkbox"/>	K1-SB = 0 ms	<input type="checkbox"/>	KS28 = 0 ms	<input type="checkbox"/>
[K2] + [K1SB_X K2] + [KS28_60_C]	K2 = 5.5 ms	<input type="checkbox"/>	K1-SB = 5.5 ms	<input type="checkbox"/>	KS28 = 0 ms	<input type="checkbox"/>
[K2] + [K1SB_X K2] + [KS28_60_Cx]	K2 = 3.5 ms	<input type="checkbox"/>	K1-SB = 3.5 ms	<input type="checkbox"/>	KS28 = 0 ms	<input type="checkbox"/>
[K2] + [K1SB_60] + [KS28_60]	K2 = 6 ms	<input type="checkbox"/>	K1-SB = 0 ms	<input type="checkbox"/>	KS28 = 6 ms	<input type="checkbox"/>
[K2] + [K1SB_60] + [KS28_60_C]	K2 = 6 ms	<input type="checkbox"/>	K1-SB = 0 ms	<input type="checkbox"/>	KS28 = 0.5 ms	<input type="checkbox"/>
[K2] + [K1SB_60] + [KS28_60_Cx]	K2 = 6 ms	<input type="checkbox"/>	K1-SB = 0 ms	<input type="checkbox"/>	KS28 = 4 ms	<input type="checkbox"/>

SB28

The SB28 provides an extension of the bandwidth in the low end, down to 25 Hz.

Line source with SB28

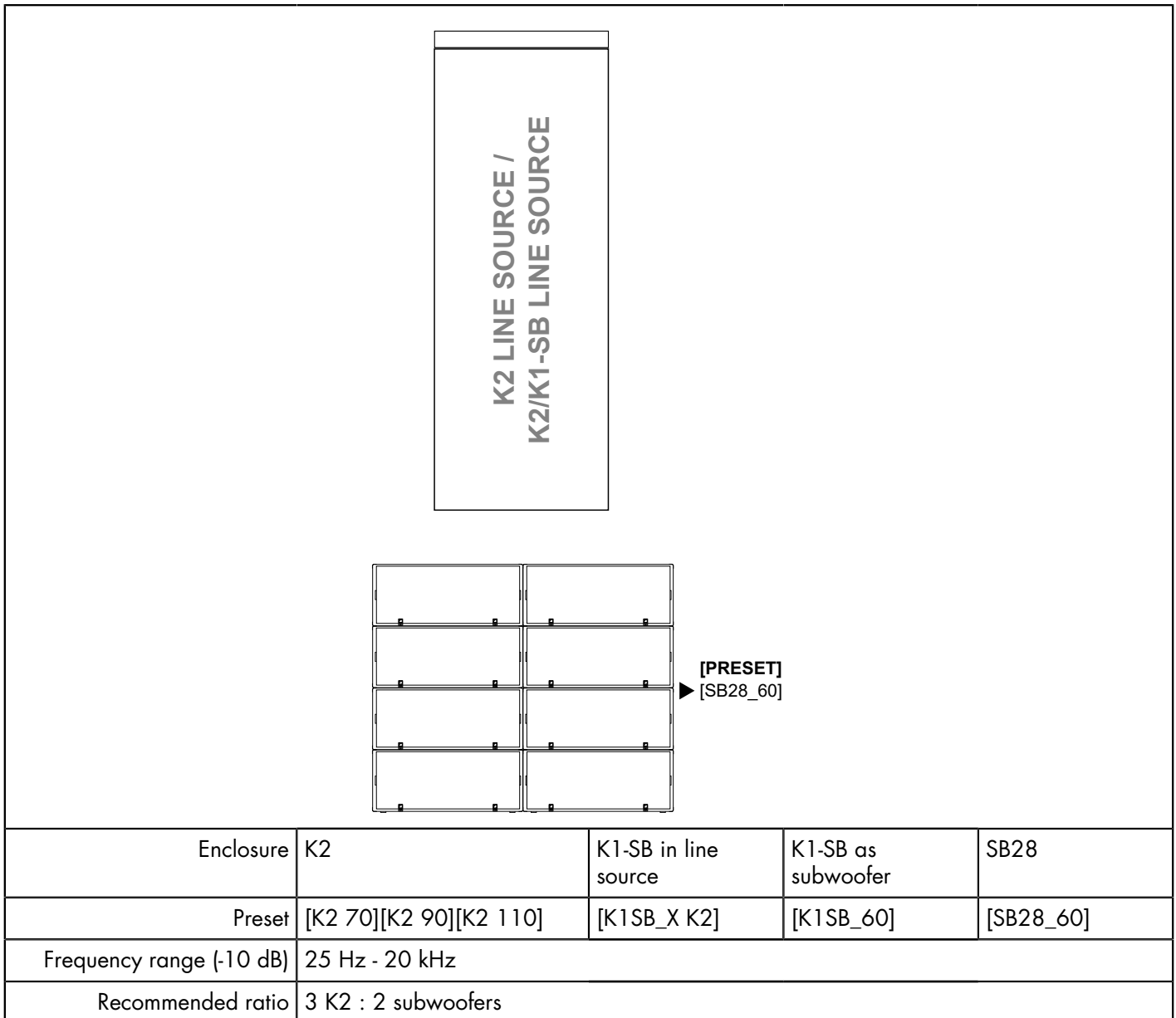

- ! Grouping subwoofers**
Place the subwoofer enclosures side by side. If not possible, the maximum distance between two adjacent acoustic centers must be 2.8 m or 1.7 m if the upper frequency limit of the subwoofer system is at 60 Hz or 100 Hz, respectively.
- ! Use [xxxx_xx_C] or [xxxx_xx_Cx] on a reversed subwoofer in a cardioid configuration**
The cardioid configuration consists in reversing 1 element in an array of 4 subwoofers.
Refer to the subwoofer owner's manual and to the **Cardioid configurations** technical bulletin.
- ! Delay values**
Do not forget to add the pre-alignment and geometric delays depending on the configuration.
- ! When using [K2 70], [K2 90], or [K2 110] with [K1SB_X K2], do not add any delay value between the K2 and K1-SB elements of a same line source.**

Pre-alignment delays**K2 + SB28**

presets	pre-alignment delay values and polarity settings			
[K2] + [SB28_60]	K2 = 0.5 ms	<input type="checkbox"/>	SB28 = 0 ms	<input type="checkbox"/>
[K2] + [SB28_60_C]	K2 = 6 ms	<input type="checkbox"/>	SB28 = 0 ms	<input type="checkbox"/>
[K2] + [SB28_60_Cx]	K2 = 4 ms	<input type="checkbox"/>	SB28 = 0 ms	<input type="checkbox"/>

K2 + K1-SB + SB28

presets	pre-alignment delay values and polarity settings					
[K2] + [K1SB_X K2] + [SB28_60]	K2 = 0 ms	<input type="checkbox"/>	K1-SB = 0 ms	<input type="checkbox"/>	SB28 = 0 ms	<input type="checkbox"/>
[K2] + [K1SB_X K2] + [SB28_60_C]	K2 = 5.5 ms	<input type="checkbox"/>	K1-SB = 5.5 ms	<input type="checkbox"/>	SB28 = 0 ms	<input type="checkbox"/>
[K2] + [K1SB_X K2] + [SB28_60_Cx]	K2 = 3.5 ms	<input type="checkbox"/>	K1-SB = 3.5 ms	<input type="checkbox"/>	SB28 = 0 ms	<input type="checkbox"/>
[K2] + [K1SB_60] + [SB28_60]	K2 = 6 ms	<input type="checkbox"/>	K1-SB = 0 ms	<input type="checkbox"/>	SB28 = 6 ms	<input type="checkbox"/>
[K2] + [K1SB_60] + [SB28_60_C]	K2 = 6 ms	<input type="checkbox"/>	K1-SB = 0 ms	<input type="checkbox"/>	SB28 = 0.5 ms	<input type="checkbox"/>
[K2] + [K1SB_60] + [SB28_60_Cx]	K2 = 6 ms	<input type="checkbox"/>	K1-SB = 0 ms	<input type="checkbox"/>	SB28 = 4 ms	<input type="checkbox"/>

Additional downfill element

All K2 system configurations can be combined with an additional Kara II line source downfill system. This allows an extension of the vertical coverage to the closer audience.

Kara II

The [KARAIIDOWNK2] preset features specific settings to optimize the acoustic coupling between the Kara II and K2 line sources.

! The [KARAIIDOWNK2] preset is optimized for a **110°** fins setting on Kara II.

The Kara II enclosure is driven by the LA4X / LA8 / LA12X amplified controller.

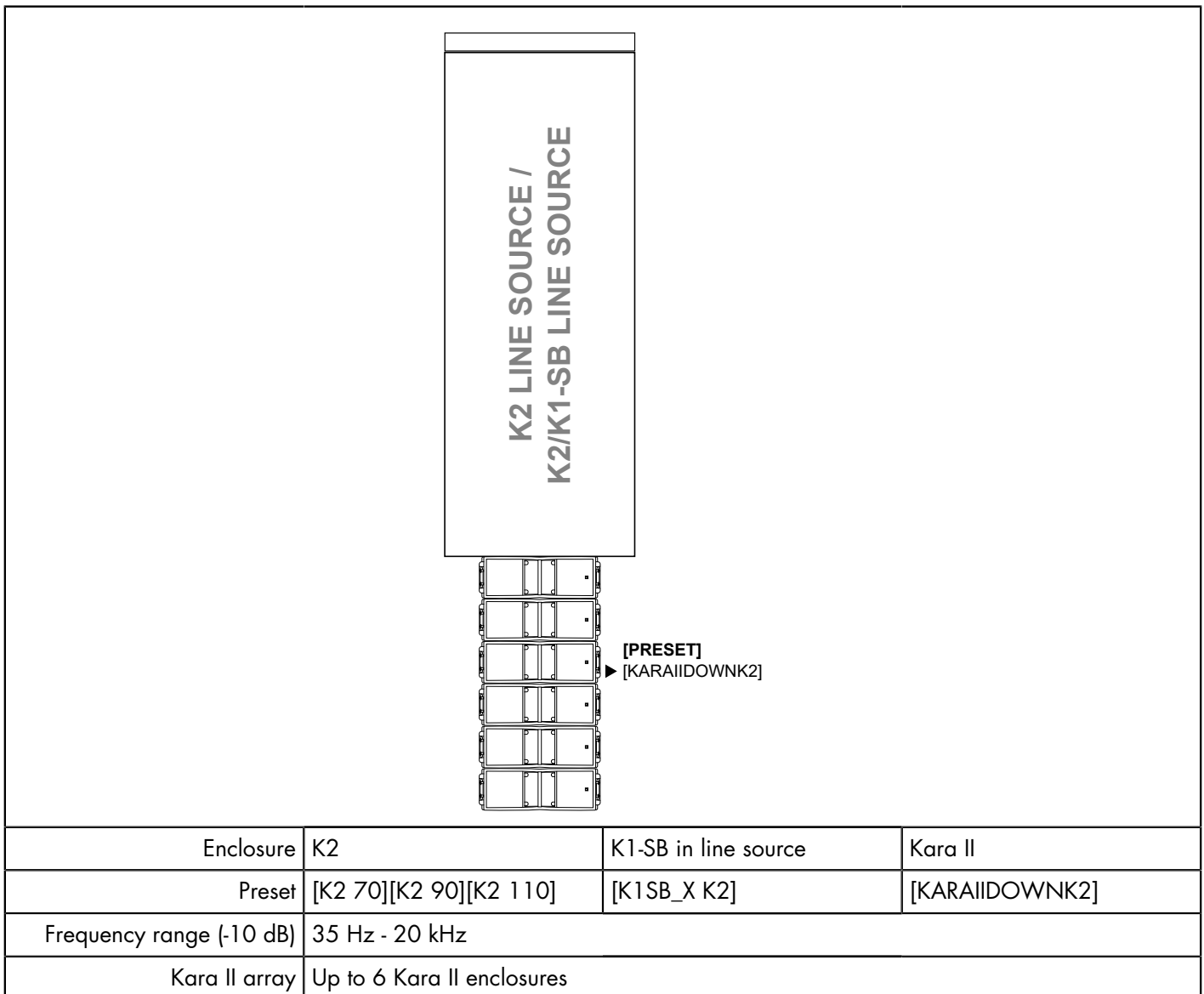

! Do not add any delay between the K2 and Kara II elements of a mixed line source.

! When using [K2 70], [K2 90], or [K2 110] with [K1SB_X K2], do not add any delay value between the K2 and K1-SB elements of a same line source.

i Using the Kara II system

Refer to the **Kara II owner's manual** for the operating modes of Kara II as a main system.

Inspection and preventive maintenance

How to do preventive maintenance

Inspect the system before any deployment and after any corrective maintenance operation.

Perform preventive maintenance at least once a year.

Refer to the maintenance manuals for advanced maintenance.

Rigging and hardware

Perform the [Rigging part inspection](#) (p.43) on each rigging part.

Use the [Mechanical system overview](#) (p.43) to identify critical parts of the system and apply the specific checks described in the [Inspection references](#) (p.49).

Do the [Rigging check](#) (p.54).

If any parts are damaged, contact your L-Acoustics representative for further instructions.

Acoustics

Perform the [Enclosure check](#) (p.57).

Perform the [Listening test](#) (p.59) to detect any degradation in sound quality.

If necessary, refer to the [Corrective maintenance](#) (p.129) section for speaker repair kits and maintenance instructions.

Rigging part inspection

About this task

For critical rigging parts, use the [Inspection references](#) (p.49) for comparison and specific manipulations.

Prerequisite

Perform the inspection in a well-lit environment.

Procedure

1. Check that the rigging part is present.
2. If applicable, disassemble the rigging part from the enclosure or the rigging accessory.

Check that the tethers are intact and safely secured.

3. Inspect the part from every side.

Compare with the **reference pictures**.

Check for:

- corrosion
- wear and cracks
- bends and dents
- holes
- missing safety cues
- missing identification labels
- missing or loose fasteners



Replacing screws

If a screw is loose, remove and replace it.

Always use the new screws provided in the repair kit.

If no new screw is available, add blue threadlocker before reusing the screw.

Do not apply more than the indicated torque.

4. Check the **geometry** of the part to identify critical deformations.

Place the rigging part on a flat surface or hold a level against it.

5. Check the **moving parts**.

Make sure that the mechanism engages correctly.



What to do next

If a problem is detected, perform the authorized maintenance operations or contact your L-Acoustics representative.

Mechanical system overview

Critical parts of the lifting chains are highlighted.



The  indicates a visual inspection. The  indicates a functional check.



Perform the [Rigging part inspection](#) (p.43) on critical parts.

For each part, refer to the [Inspection references](#) (p.49).



Replacing screws

If a screw is loose, remove and replace it.

Always use the new screws provided in the repair kit.

If no new screw is available, add blue threadlocker before reusing the screw.

Do not apply more than the indicated torque.

K2 mixed array with K2-BAR, K2-BUMP, K1-SB, and K2-LINK

Refer to [Rigging part inspection](#) (p.43).



[Shackles](#) (p.52)

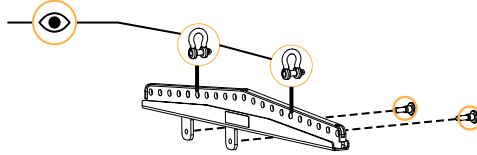

[Ball-locking pins](#) (p.49)

[Ball-locking pins](#) (p.49)

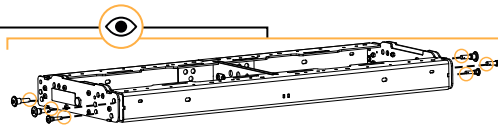

Rear and front rigging arms rotate correctly

[Ball-locking pins](#) (p.49)

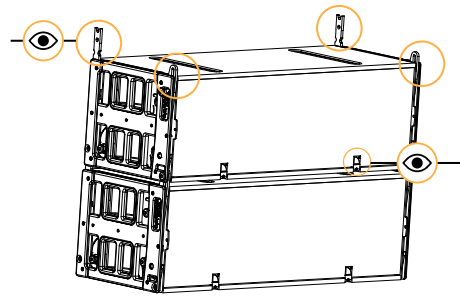

[Grill safety](#) (p.53)

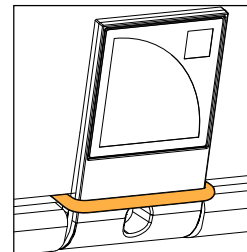

[Ball-locking pins](#) (p.49)



[Rigging check](#) (p.54)

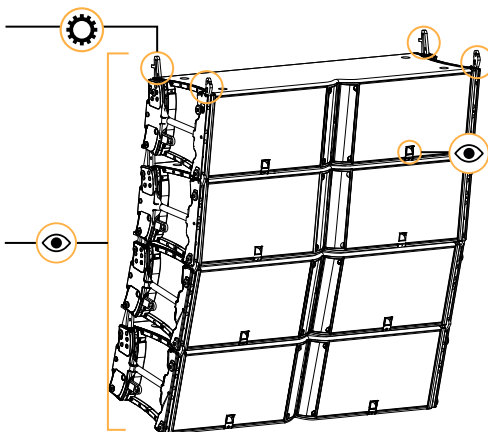

[Grill safety](#) (p.53)

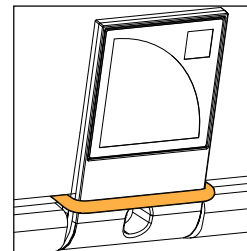

[Ball-locking pins](#) (p.49)

K2 array with K2-BUMP and KARADOWNK2

Refer to [Inspection references](#) (p.49).

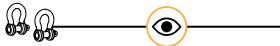

Shackles (p.52)

Ball-locking pins (p.49)

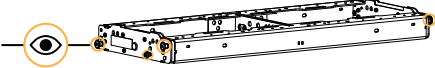

Rigging check (p.54)



Grill safety (p.53)

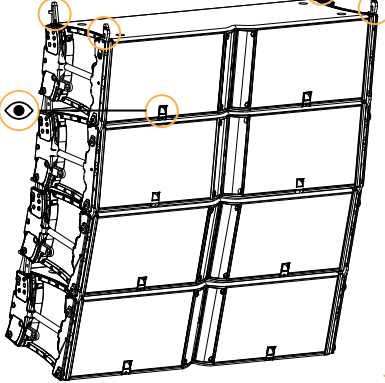
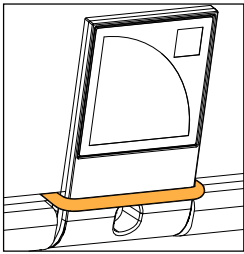

Ball-locking pins (p.49)

Ball-locking pins (p.49)

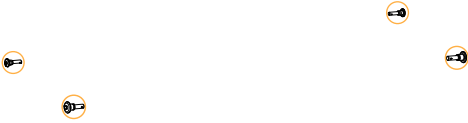
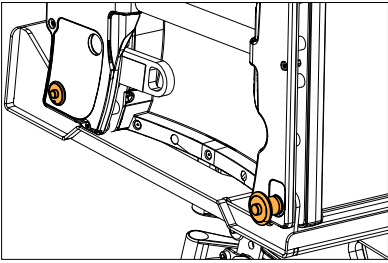

Ball-locking pins (p.49)

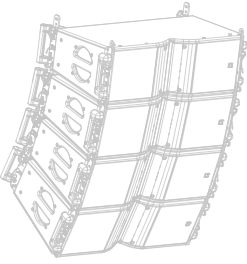
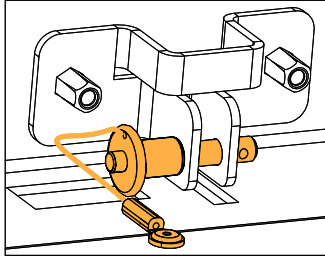
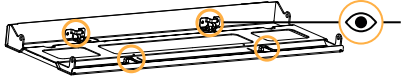

Refer to the **Kara II owner's manual**.

K2 array with K2-CHARIOT and K2-JACK

Refer to [Inspection references](#) (p.49).

[Grill safety](#) (p.53)

[Ball-locking pins](#) (p.49)
[Rigging check](#) (p.54)

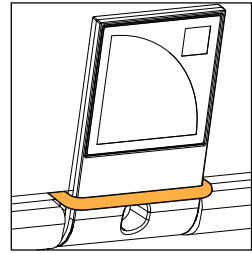
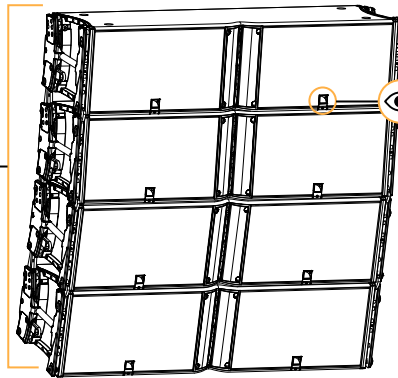

rear rigging arms rotate correctly

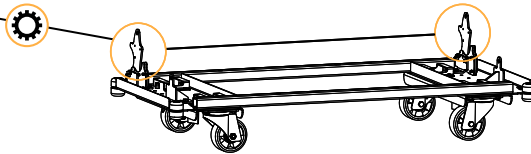

turn the hand wheels:
the central part is raised
(clockwise) or lowered
(counter-clockwise)

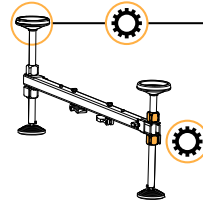
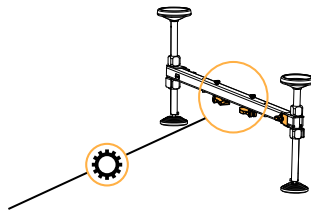

check the integrity of the
quarter-turn locking system

the locking handles can be
tightened and loosened by
hand

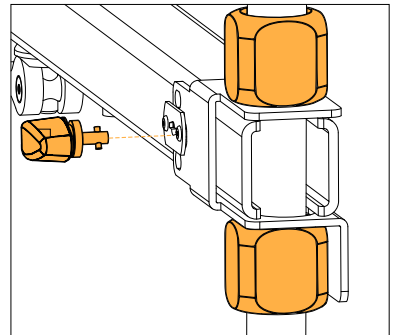

K2 array with K2-BAR, K2-RAKMOUNT, and K2-BUMP

Refer to [Inspection references](#) (p.49).



Shackles (p.52)

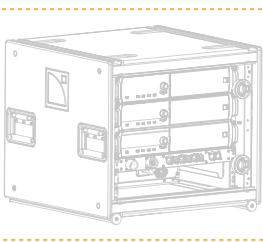
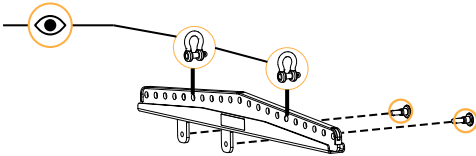

Refer to the **LA-RAK II documentation** for more information.

screws are tightened

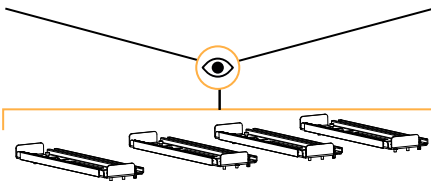
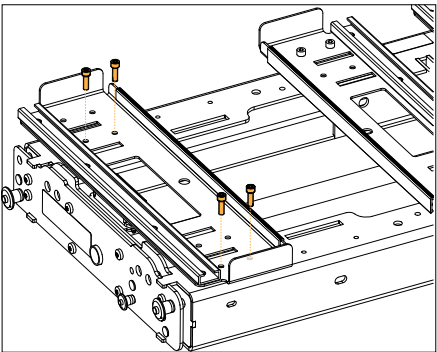

Ball-locking pins (p.49)

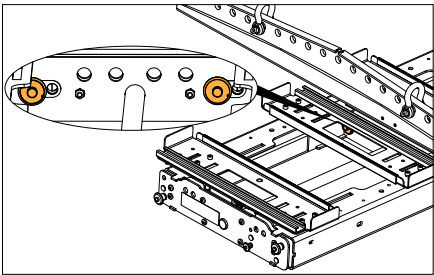

Ball-locking pins (p.49)

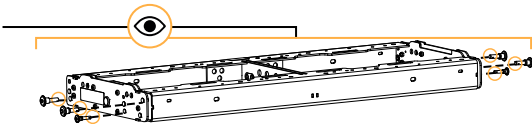

Rigging check (p.54)



Ball-locking pins (p.49)

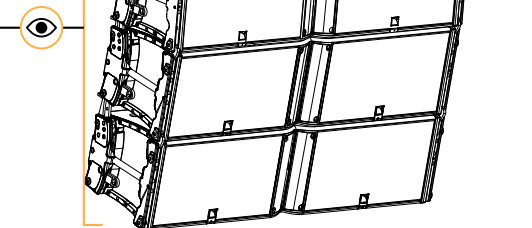

Grill safety (p.53)

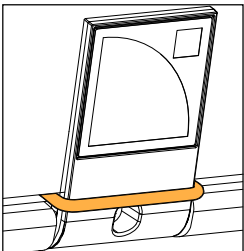

K2 array with K2-RIGBAR as pullback

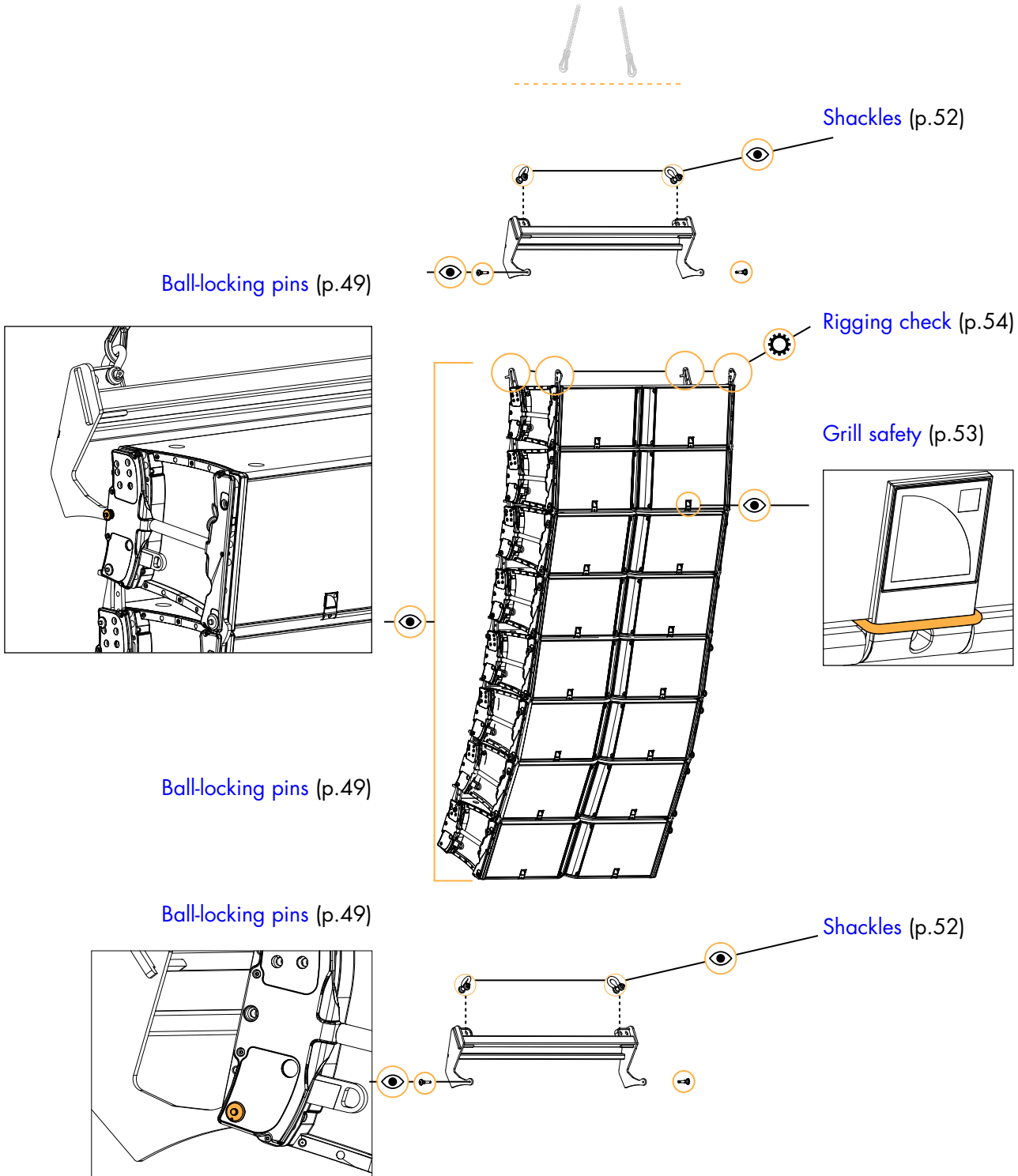

Inspection references

Ball-locking pins

Reference pictures

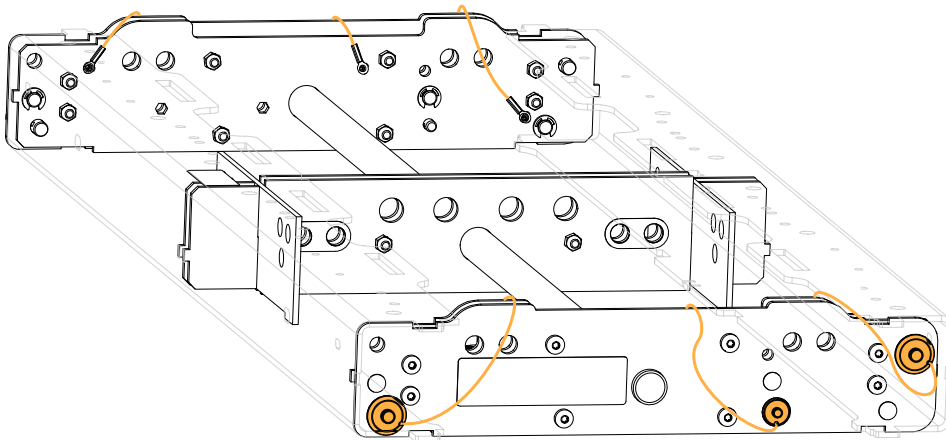

tether (K2-BUMP)

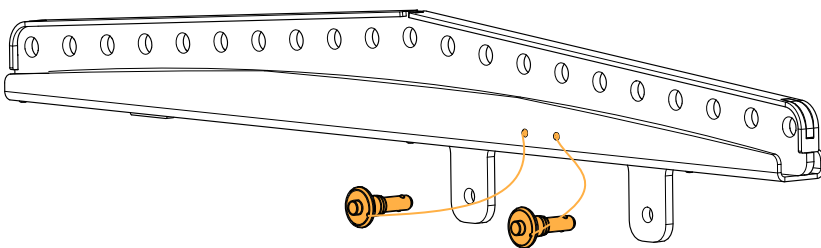

tether (K2-BAR)

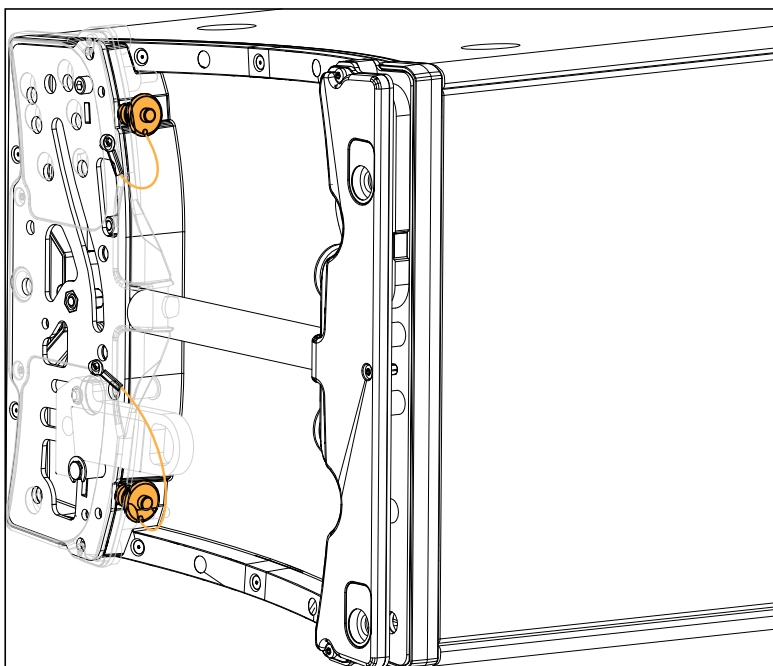

tether (K2)

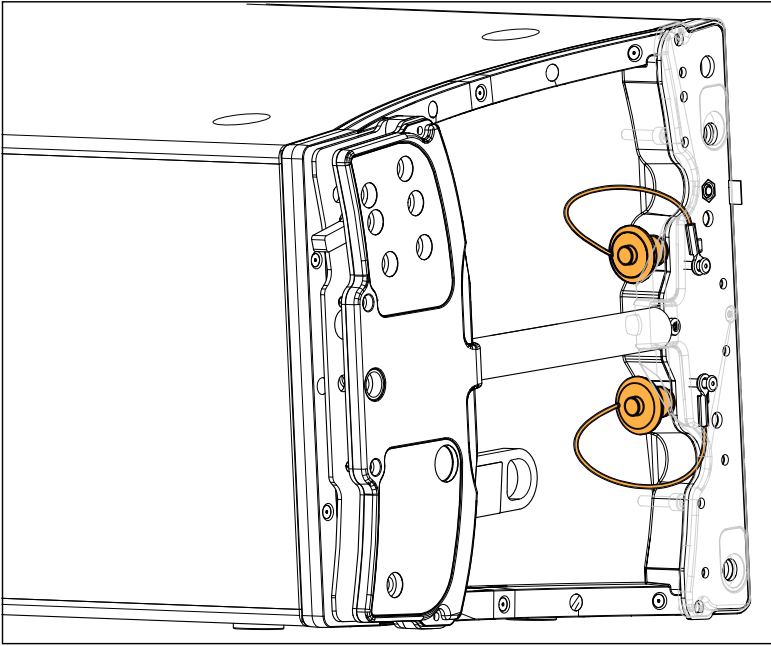

tether (K2)

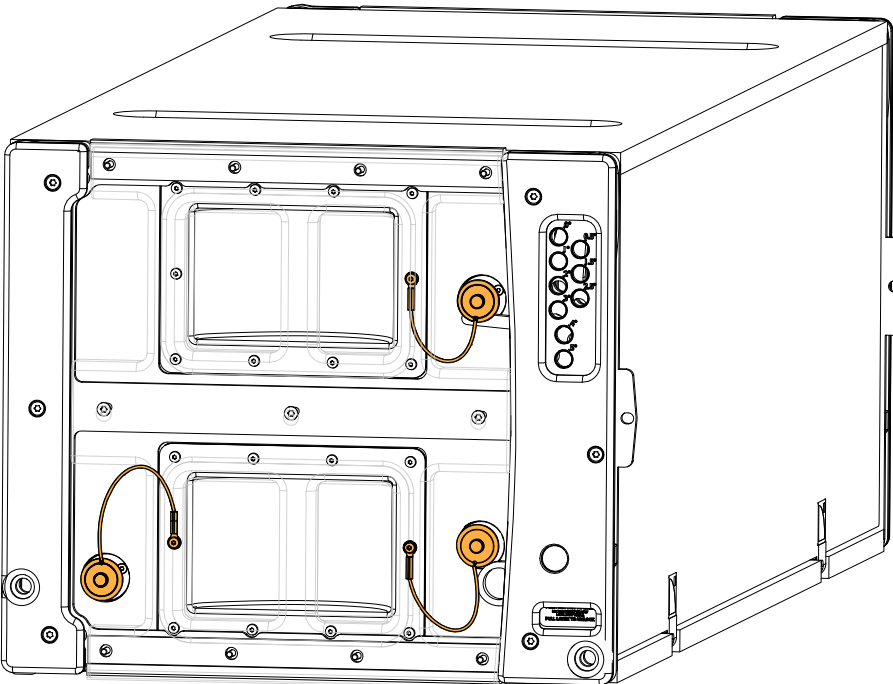

tether (K1-SB)

Moving parts

1. Press the push button. The ball-locking mechanism is retracted.
2. Release the button. The ball-locking mechanism is activated.

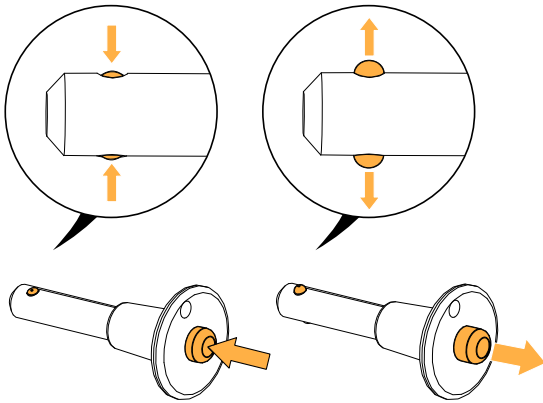

3. Insert the pin in each storage and rigging hole. Pull and rotate the pin. The pin must remain inside the hole.

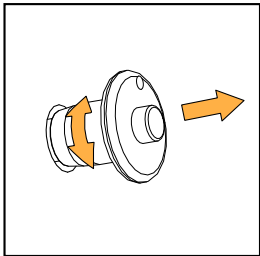

If the pin is inserted in two plates, the ball must pass through both plates and lock the pin in place.

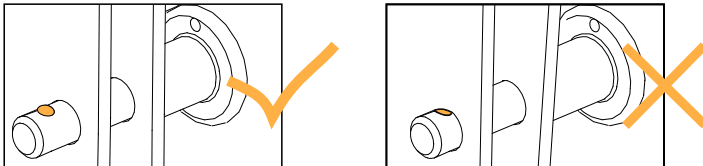

If the check fails, **immediately withdraw the product from use and contact L-Acoustics.**

Related tasks

[Rigging part inspection](#) (p.43)

Shackles

Moving parts

Drive the shackle axis in its lodging. Make sure that the end is flush with the shackle.

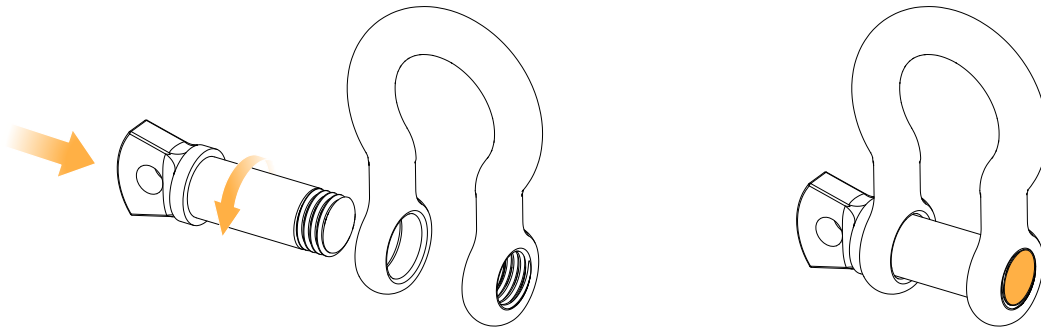

Related tasks

[Rigging part inspection](#) (p.43)

Grill safety

Moving parts

Visually inspect the grill safety.

Make sure that the O-rings are not damaged.

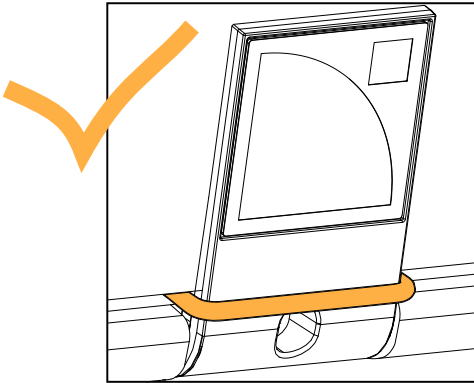

Make sure that the screw is tightened.

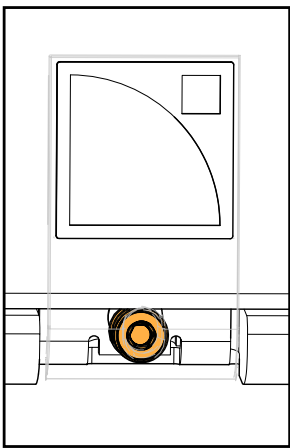

Pull on the O-rings:

- Make sure they do not break.
- Make sure they are not loose.

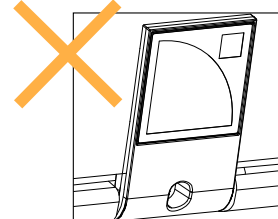
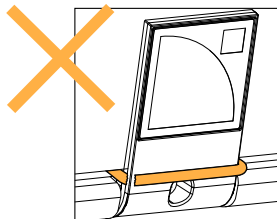
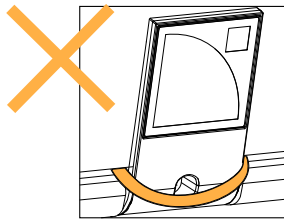
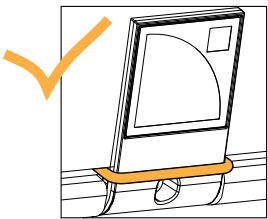

If the O-rings are damaged or missing, refer to the **GRILL (p.133)** to replace them.

Rigging check

Procedure

1. Position one K2 on the first one.
2. Secure the front rigging arms at the LINK holes.

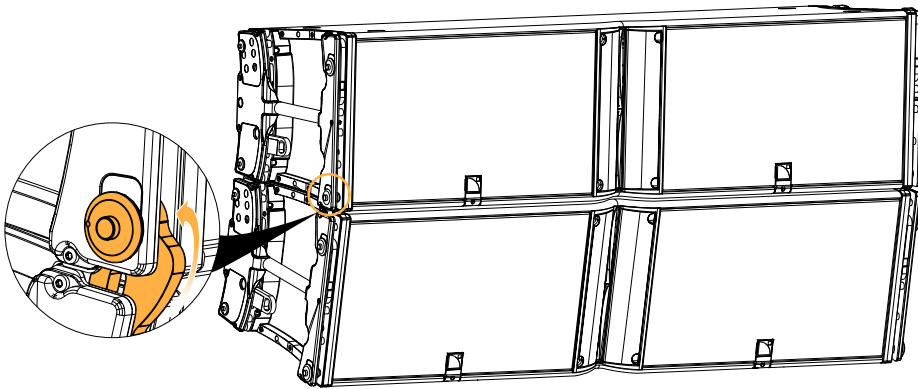

- The front rigging arms can be deployed with some resistance, and rotate correctly.

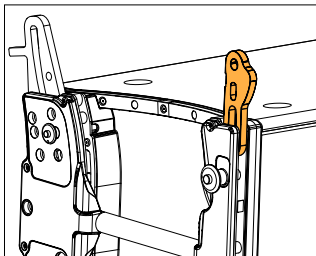

- The ball-type plunger protrudes out the rigging system.

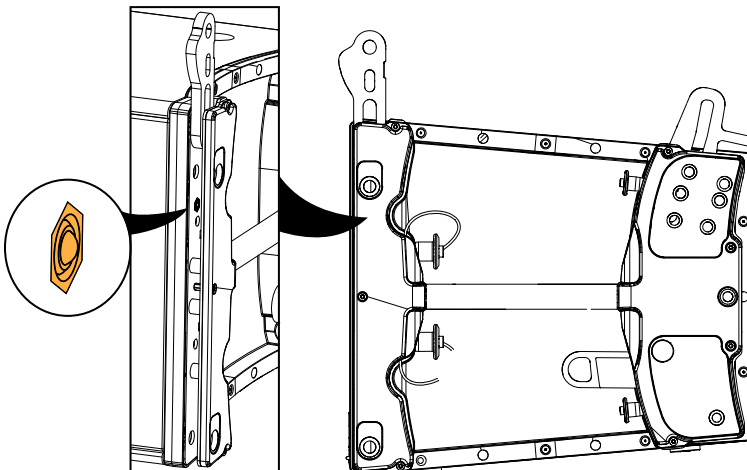

3. Secure the rear rigging arms at the LINK holes.

- The rear rigging arms can be deployed with some resistance, and slide correctly.

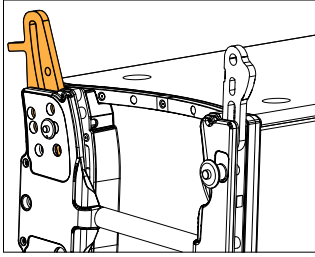

- The ball-type plunger protrudes out the rigging system.

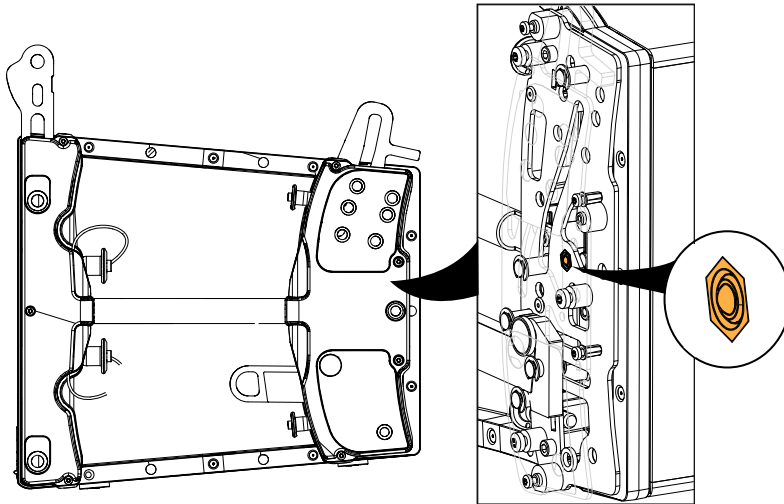

4. Secure the rear rigging arms at one of the inter-enclosure holes.

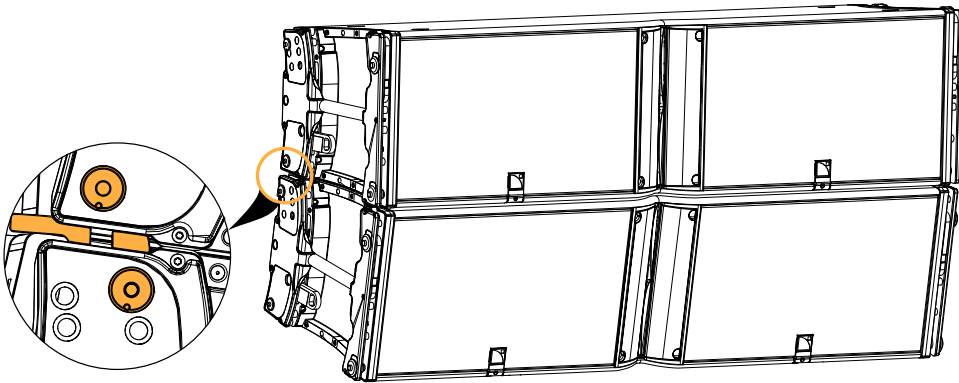

5. Press the button to activate the automatic locking system.

- The latch slightly retracts when the button is pushed (yellow label visible).

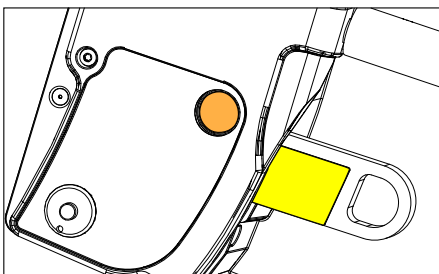

6. Hold and lift the array to lock the inter-enclosure angles.

- The two enclosures remain attached.
- The automatic locking system button locks and the latches engage (no yellow label visible).

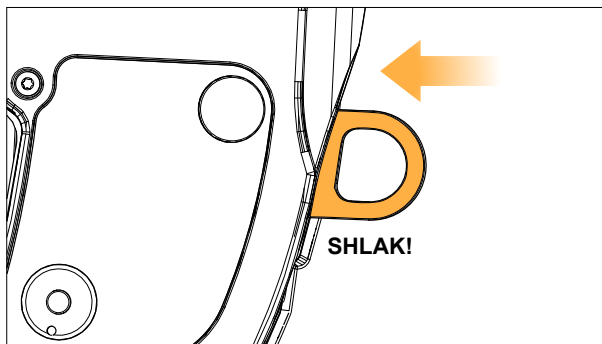

7. Disassemble the two enclosures.

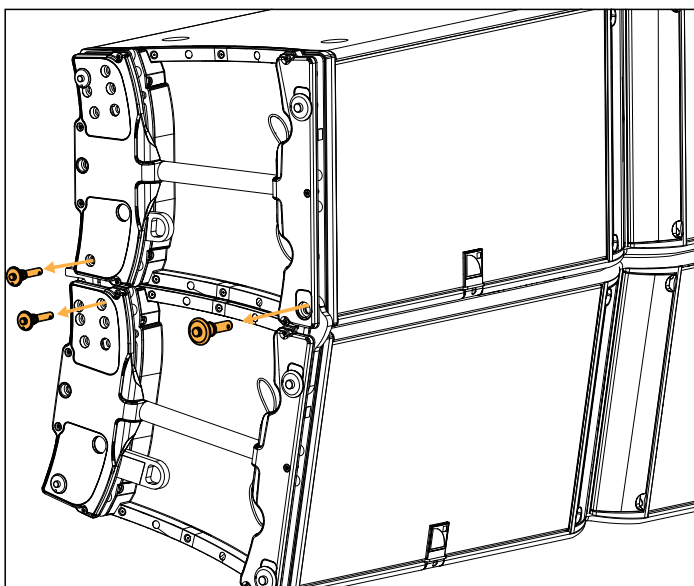

Risk of trapping fingers

When disassembling the enclosures, hold the top one by the handles.

8. Repeat the procedure with the other enclosures.

Acoustical check

Enclosure check



This feature is available on:

LA4X
LA12X

ENCLOSURE CHECK measures impedance at the reference frequencies for the connected loudspeaker family. The measured impedance is compared to the expected range allowing for fast detection of loudspeakers presenting circuit continuity issues.



The results can be used for preliminary diagnosis but cannot replace a comprehensive quality control.

Prerequisite



ENCLOSURE CHECK measurements can only be reliable if the following requirements are met:

Environment and temperature:

- Ambient temperature must be comprised between 0 °C / 32 °F and 40 °C / 104 °F. Ideal temperature is 20 °C / 68 °F.
- Enclosures must be at room temperature. If warm from a recent high level use or recently moved from a cold environment, let the loudspeakers reach room temperature before starting.

Enclosures:

- Enclosures must be included in the embedded factory preset library.
- Enclosures must be in nominal operating conditions:
 - Remove covers or dollies obstructing the loudspeakers or the vents.
 - Check for obvious physical damage or air leak: visually inspect the grill, gasket, cabinet, and connector plate for loose, missing or damaged parts.

Connection:

- Use only 10 m / 30 ft 4 mm² / AWG 11 speaker cables.
- Do not connect enclosures in parallel.

Amplified controllers:

- LA4X must run at least firmware version 1.1.0.
- LA4X load sensors must be calibrated. Refer to the **Load Sensor Calibration Tool** technical bulletin for more information.
- LA4X must warm up for at least 10 minutes after power up. Do not power off, reboot or switch to standby mode to avoid resetting the countdown.
- Load a preset corresponding to the connected loudspeaker's family. Presets from the user memories may be used on condition they are made of presets supported in the embedded factory preset library.

Procedure

1. Power up the amplified controller. Let LA4X warm up for at least 10 minutes.
2. Connect the loudspeaker enclosures to the amplified controller.
3. Load a preset from or built from the embedded library corresponding to the connected loudspeaker family.
4. On the amplified controller, use the encoder wheel to select **MONITORING & INFO**. Press the OK key or the encoder wheel to validate.
5. Use the encoder wheel to select **ENCLOSURE CHECK**.



Beware of sound levels.

Although the sound pressure levels generated for the ENCLOSURE CHECK are moderate, do not stay within close proximity of the loudspeakers and consider wearing ear protection.

6. Press the OK key or the encoder wheel to launch the ENCLOSURE CHECK.

The amplified controller generates short sinusoidal signals simultaneously for each connected output.

The amplified controller displays the results for each output.

7. Depending on the displayed results, follow the instructions in the table.

result	interpretation	instructions
OK	measured impedance is within expected range	enclosure is in working order electrically
?	unsupported preset family	only supported enclosures should be tested
NC	Not Connected	if cables are connected: a. inspect the cables and connections b. go to step 8 (p.58)
NOK	measured impedance is not within expected range	a. check that all the prerequisites are met, in particular that the loaded preset corresponds to the connected speaker's family b. inspect the cables and connections c. go to step 8 (p.58)
UNDEF	measured impedance is undefined	

8. Under NC, NOK and UNDEF results, press and hold the corresponding OUT key.

The amplified controller displays:

- the tested frequencies,
- information on the measured impedance:
 - OPEN for open circuit (found in NC results),
 - SHORT for short circuit (found in NOK results), or
 - a percentage of variation from the expected range (found in NOK and UNDEF results)
- the number of operational transducers out of the total

 Low variations from the expected range are acceptable: displayed percentage can be different from 0 and all transducers considered operational.

Listening test

enclosure	preset	usable bandwidth
K2	[K2 70]	35 Hz - 20 kHz
Kara II	[KARA II 70]	55 Hz - 20 kHz
SB28	[SB28_100]	25 Hz - 117 Hz
KS28	[KS28_100]	25 Hz - 110 Hz
K1-SB	[K1 SB_60]	30 Hz - 80 Hz

Procedure

1. Load the preset on an LA4X / LA8 / LA12X amplified controller.
2. Connect a sinus generator to the amplified controller.



Risk of hearing damage

Set a low sound level to start and use ear protection to adjust before testing.

3. Scan the bandwidth focusing on the usable range.
The sound should remain pure and free of unwanted noise.

Troubleshooting for LF speakers

One or more LF speaker produces distorted, buzzing, rubbing, clicking, muffled or weak sound.

Possible causes

- The screws are not tightened with the appropriate torque.
- There is an air leak in the gasket.
- There is dust on the cone.
- The cone is damaged.
- The surround is torn or delaminated.
- The voice coil or the spider is damaged.

Procedure

1. Perform the speaker disassembly procedure.
2. Visually inspect the cables and the connectors.
3. Visually inspect the speaker cone, the voice coil and the spider.

If any damage is visible, replace the speaker.

4. Carefully clean the speaker with a dry cloth.
5. Perform the reassembly procedure.
Replace the speaker gasket and the screws.
Apply the recommended torque.
6. Repeat the listening test.

If the problem persists, replace the speaker.

Troubleshooting for HF drivers

One or more HF driver produces high-frequency harmonic distortions, strange vibrations or weak sound.

Possible causes

- There are foreign particles on the air gap.
- The diaphragm is not centered correctly.
- The screws used for reassembly are too loose.
- The diaphragm is damaged.

Procedure

1. Perform the diaphragm disassembly procedure.

- 2.** Visually inspect the diaphragm and the voice coil.
If any damage is visible, replace the diaphragm.
- 3.** Clean the air gap thoroughly.
Use double-face adhesive tape to remove any particles.
- 4.** Perform the diaphragm reassembly procedure.
Apply the recommended torque.
- 5.** Repeat the listening test.
If the problem persists, replace the driver.

Rigging procedures

System setup

Ground stacking

K2 enclosures on K2-CHARIOT and K2-JACK



Final check

After the setup, always verify no yellow labels are visible on the front and on both sides of the array.

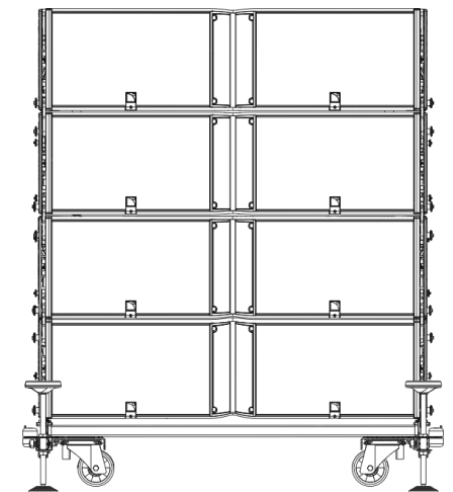

Procedure

1. Place a block of four K2 enclosures at the final position.
2. Preset the inter-enclosures angles.
3. Attach the K2-JACK stabilizers to the K2-CHARIOT.
4. If needed, add one or two K2 enclosures to the stack.
5. Preset the inter-enclosure angles for the additional enclosures.
6. Push the topmost enclosure forward until all the automatic locks are in place and verify that there is no yellow label visible.
7. If necessary, change the position of the K2-CHARIOT rear rigging arm.
8. If necessary, fine-tune the site angle of the stack by adjusting the height of the stabilizers feet.

References

- A - [Preparing a block of 4 K2](#) (p.69).
- B - [Preset the inter-enclosure angles](#) (p.73)
- C - [Attaching K2-JACK stabilizers to K2-CHARIOT](#) (p.75).
- A - [Preparing a block of 4 K2](#) (p.69).
- B - [Preset the inter-enclosure angles](#) (p.73)
- D - [Changing the position of the K2-CHARIOT rear rigging arm](#) (p.80)
- E - [Adjusting the K2-CHARIOT site angle](#) (p.83)

K2 enclosures on K1-SB

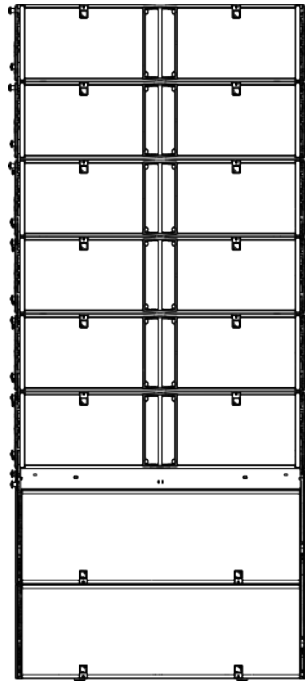

Procedure

1. Stack as many K1-SB enclosures as necessary.
2. Position and attach a K2-BUMP on the K1-SB stack.
3. Position and attach an upside down K2 on the K2-BUMP and add as many K2 enclosures on top of the first one.

References

K1 rigging manual

[L - Attaching K1 or K1-SB under K2-BUMP](#)
(p.113)

[C - Attaching K2-JACK stabilizers to K2-CHARIOT](#) (p.75)

Flying



Final check

After the setup, always verify no yellow labels are visible on the front and on both sides of the array.

At least one motor for each K2-BAR

When using two K2-BAR, do not implement a bridle between the bars.

Nobody behind the array when lifting enclosures

To avoid collisions caused by the swinging motion, do not stand behind the array when lifting the enclosures.

Safe maximum of 12 K2 enclosures in a pullback configuration

Up to 12 K2.

Space between pullback rigging points

The space between the two lifting points used for this configuration must be aligned with the array pickup points.

The deployment load-bearing lines must be parallel to each other.



Before setup, choose a flying option

Refer to SOUNDVISION modeling and to the elements for flying in [Rigging system description](#) (p.19).

To implement a pullback with a K2-BAR:



in **front extension** attach the shackle to **hole #1**.

in **rear extension** attach the shackle to **hole #21**.

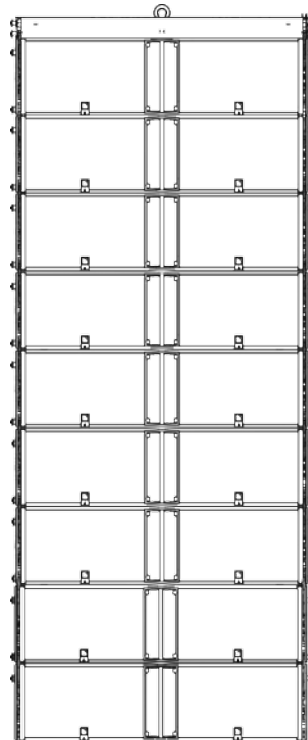
K2 enclosures under K2-BUMP



Procedure

1. Prepare all the blocks of 4 K2 necessary to build the array.
 2. Preset the inter-enclosures angles.
 3. Place and open a K-BUMPFLIGHT under the motor.
 4. If necessary, attach one or two K2-BAR to the K2-BUMP.
 5. If necessary, stack one or two LA-RAK / LA-RAK II on the K2-BUMP.
 - Place K2-BUMP to the ground.
 - Stack the LA-RAK / LA-RAK II on the K2-BUMP.
 - Raise the K2-BUMP.
 6. Prepare the pickup points.
 7. Lift the assembly so you can position a block of four K2 under it.
 8. Attach the block of four K2 to the K2-BUMP.
 9. Lift the assembly so you can position a block of four K2 under it.
-  Verify that no yellow label is visible on both sides of the array.
10. Attach the block of four K2 enclosures to the bottom of the array.
-  Verify that the rear rigging arms are secured by pins and that no yellow label is visible on the front.
11. Repeat the two previous steps until the array is complete.
 12. If necessary, implement a pullback with K2-RIGBAR.
 13. Raise the array to its final trim height.
 14. Adjust site and azimuth angles.

References

[A - Preparing a block of 4 K2 \(p.69\)](#)

[B - Preset the inter-enclosure angles \(p.73\)](#)

[G - Attaching K2-BAR to K2-BUMP \(p.89\)](#)

[M - Mounting LA-RAK/LA-RAK II on K2-BUMP \(p.115\)](#)

Refer to **Soundvision** for the number and position of the shackles.

[H - Attaching a block of four K2 under K2-BUMP \(p.92\)](#)

[J - Attaching a block of four K2 under K2 \(p.100\)](#)

[N - Using a K2-RIGBAR to implement a pullback \(p.120\)](#)

K2 enclosures under K2-RIGBAR

Final check

After the setup, always verify no yellow labels are visible on the front and on both sides of the array.

Space between pullback rigging points

The space between the two lifting points used for this configuration must be aligned with the array pickup points.
The deployment load-bearing lines must be parallel to each other.

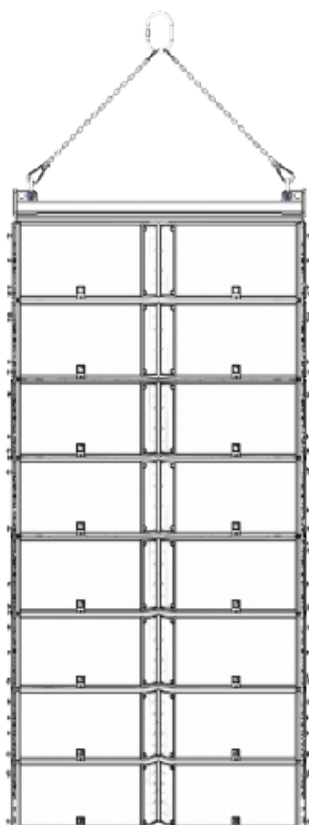

Procedure

1. Prepare all the blocks of 4 K2 necessary to build the array.
2. Preset the inter-enclosures angles.
3. Attach the K2-RIGBAR on the block of four K2.
4. Lift the array so you can position another block of four K2 under it.



Verify that no yellow label is visible on both sides of the array.

References

[A - Preparing a block of 4 K2 \(p.69\)](#)

[B - Preset the inter-enclosure angles \(p.73\)](#)

[I - Attaching a block of four K2 under K2-RIGBAR \(p.97\)](#)

Procedure

5. Position and attach a block of four K2 enclosures under the array.



Verify that the rigging arms at the back are secured by pins and that no yellow label is visible on the front.

6. Repeat the two previous steps until the array is complete.

7. If necessary, implement a pullback with K2-RIGBAR.

8. Raise the array to its final trim height.

References

[J - Attaching a block of four K2 under K2 \(p.100\)](#)

[N - Using a K2-RIGBAR to implement a pullback \(p.120\)](#)

K2 enclosures under K1 system elements



Final check

After the setup, always verify no yellow labels are visible on the front and on both sides of the array. When using two K2-BAR, do not implement a bridle between the bars. Always use at least two motors.



Before setup, choose a flying option

Refer to Soundvision modeling and to the elements for ground-stacking in [Rigging system description](#) (p.19).

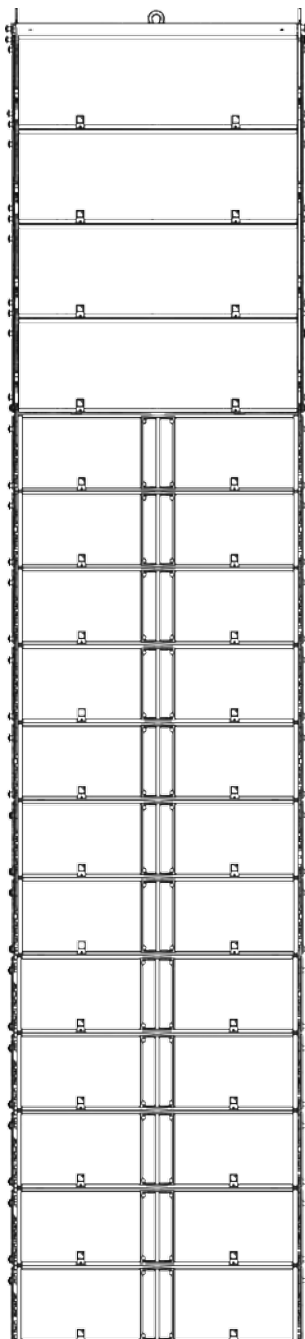

K1-SB array setup

Procedure

1. Refer to your Soundvision model to define which frame to use.
2. If you are using the K1-BUMP, refer to the **K1 rigging manual** to set up the K1-SB part of the array.
3. If you are using the K2-BUMP, place an open K-BUMPFLIGHT under the motor.
4. If necessary, attach one or two K2-BAR to the K2-BUMP.
5. If necessary, stack one or two LA-RAK / LA-RAK II on the K2-BUMP.
 - Place K2-BUMP to the ground.
 - Stack the LA-RAK / LA-RAK II on the K2-BUMP.
 - Raise the K2-BUMP.
6. Prepare the pickup points.
7. Lift the assembly so you can position a block of K1-SB under it.
8. Attach the K1-SB block to the K2-BUMP.
9. Repeat the last two steps until the K1-SB array is complete.

K2 array setup

Procedure

1. Prepare all the blocks of 4 K2 necessary to build the array.
2. Preset the inter-enclosures angles.

K1-SB and K2 arrays connection

Procedure

1. Lift the K1-SB array so you can position a block of four K2 under it.
2. Using two K2-LINK interfaces, attach the block of K2 under the K1-SB array.



Verify that the rear rigging arms are secured by pins and that no yellow label is visible on the front.

3. Lift the array so you can position a block of four K2 under it.



Verify that no yellow label is visible on both sides of the array.

4. Attach the block of four K2 to the bottom enclosure of the array.



Verify that the rear rigging arms are secured by pins and that no yellow label is visible on the front.

5. Repeat the last two steps until the array is complete.
6. Raise the array to its final trim height.
7. Adjust site and azimuth angles.

References

[G - Attaching K2-BAR to K2-BUMP \(p.89\)](#)

[M - Mounting LA-RAK/LA-RAK II on K2-BUMP \(p.115\)](#)

Refer to **Soundvision** for the number and position of the shackles.

[L - Attaching K1 or K1-SB under K2-BUMP \(p.113\)](#)

References

[A - Preparing a block of 4 K2 \(p.69\)](#)

[B - Preset the inter-enclosure angles \(p.73\)](#)

References

[K - Attaching a block of four K2 under a K1 system element \(p.106\)](#)

[J - Attaching a block of four K2 under K2 \(p.100\)](#)

Subset procedures

A - Preparing a block of 4 K2

min number of operators	2
--------------------------------	---

Procedure

1. Attach K2 on K2-CHARIOT.
Fully rotate the rear rigging arms of K2-CHARIOT and attach a first K2.

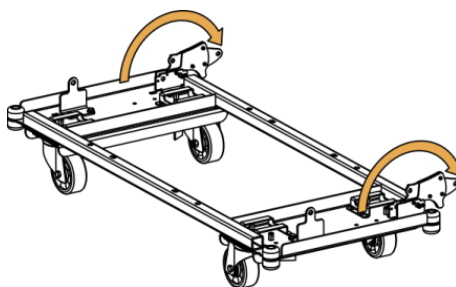
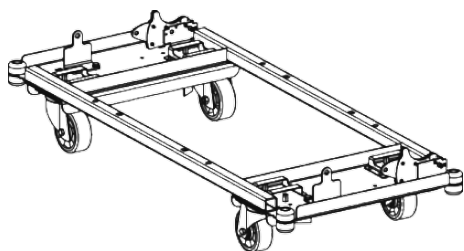

2. Position K2 on the K2-CHARIOT dolly.

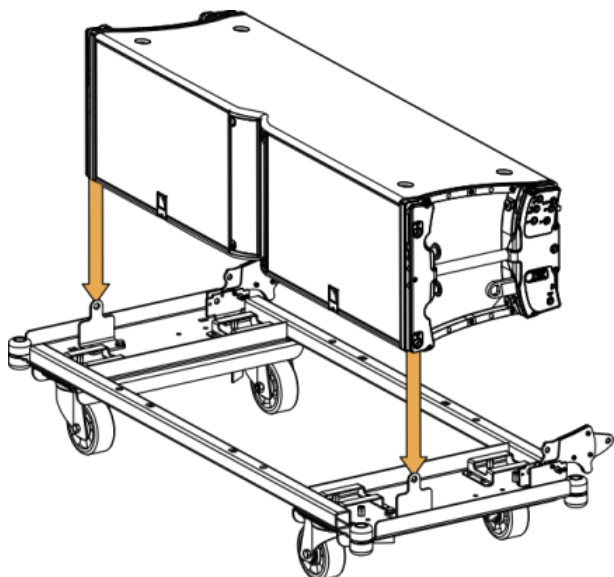

3. Secure the enclosure at the front using the LINK hole.

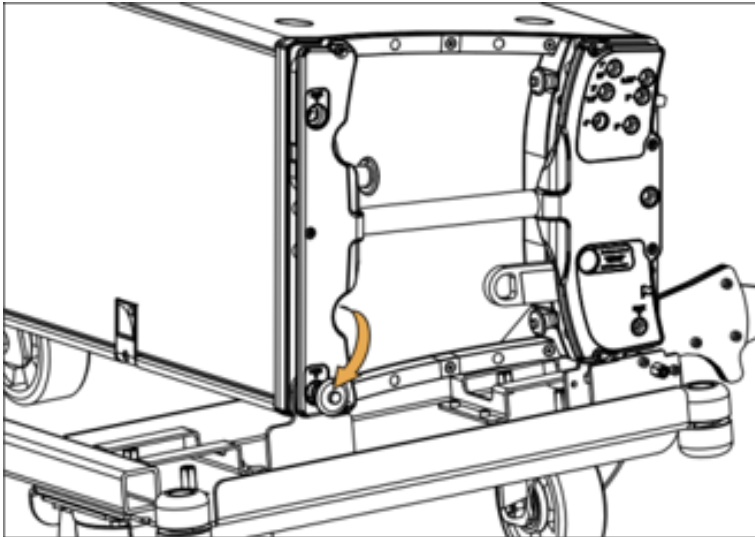

4. Lift the rear of the enclosure and rotate the dolly rear rigging arm in its upward position.

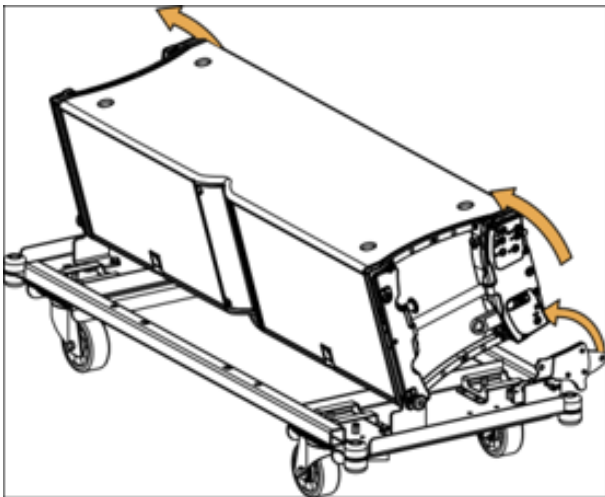

5. Secure the enclosure using the LINK hole.

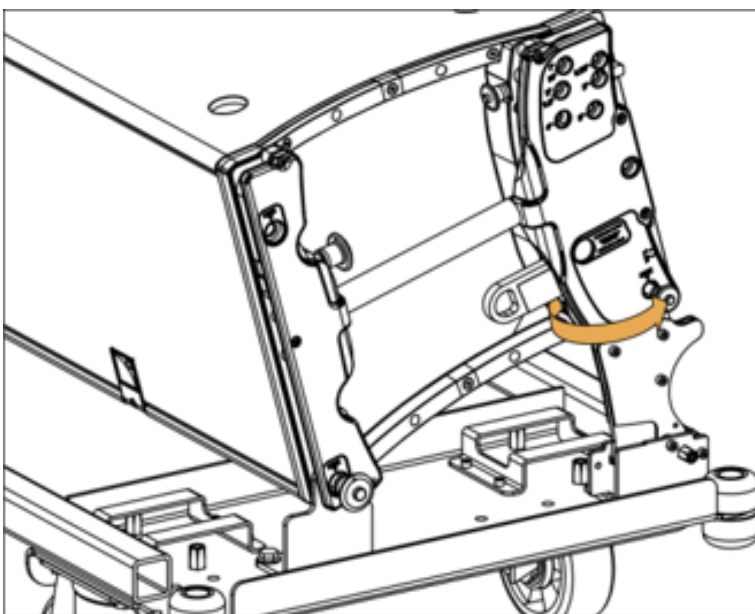

6. Position another K2 on the first one.

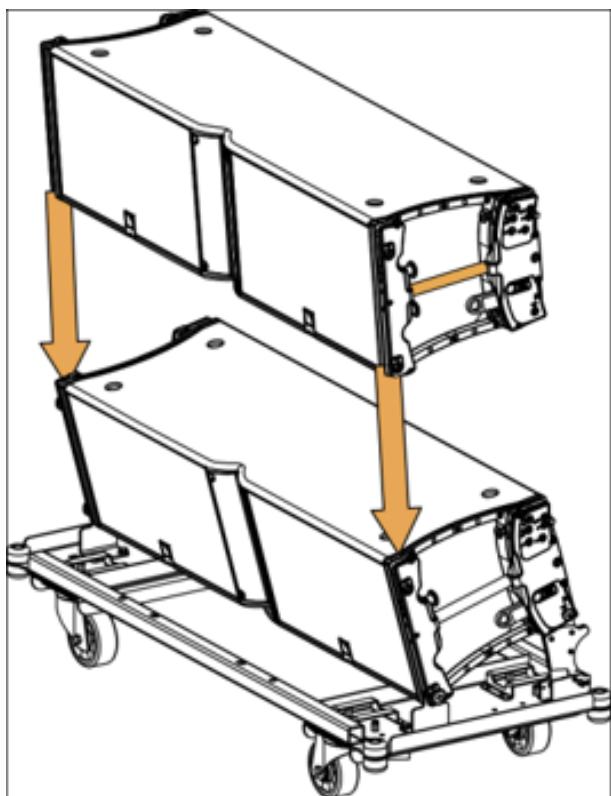

Keep holding the enclosure with the handles until the front rigging arm is secured.

7. While holding the handle, rotate the front rigging arm and secure it with both LINK pins.

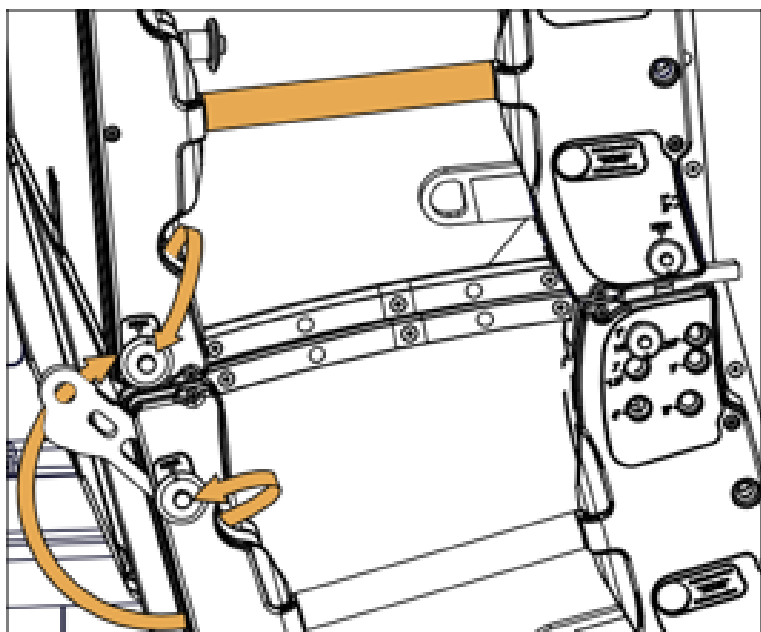

8. Slide the rear rigging arm and secure it with both pins, in the LINK and 10° holes.

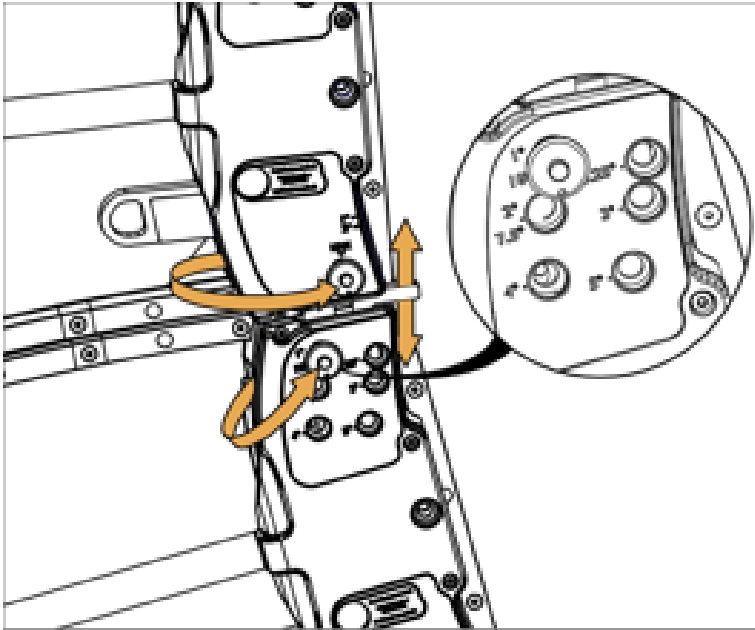

9. Make sure the automatic locking system button is unloaded.
If the button has been pressed, pull to disengage the latch.

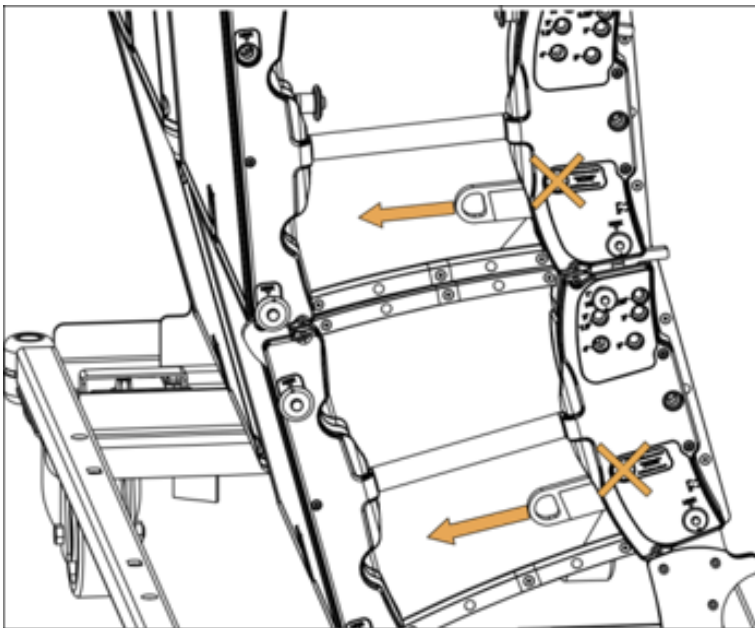

10. Repeat steps 1 (p.69) to 6 (p.71) until the block of four is complete.

B - Preset the inter-enclosure angles

Procedure

1. On both sides, remove the pin from its current angle hole.

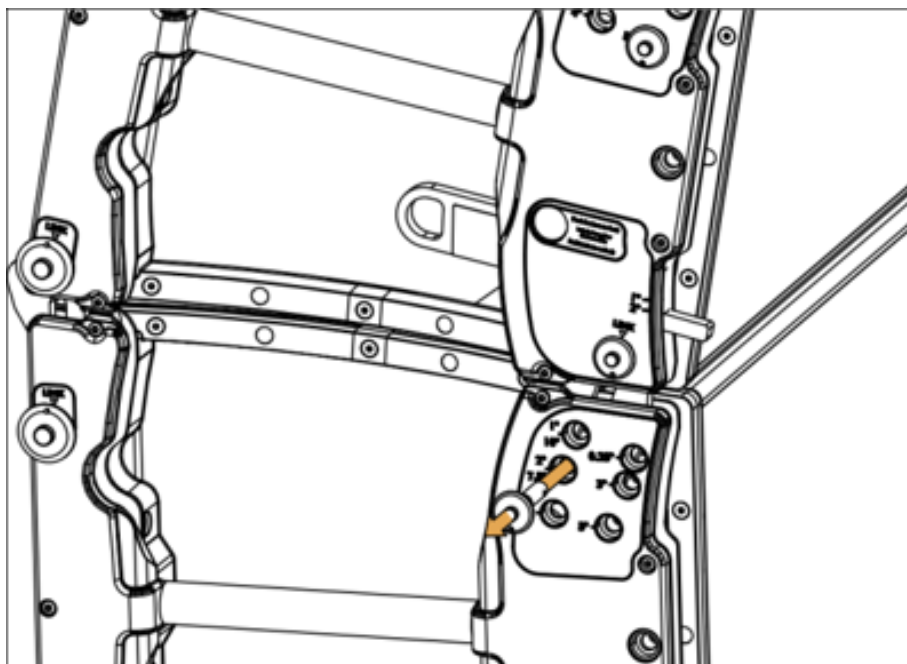

2. Position the pin at the chosen angle hole and slide the rigging arm until the pin goes in.

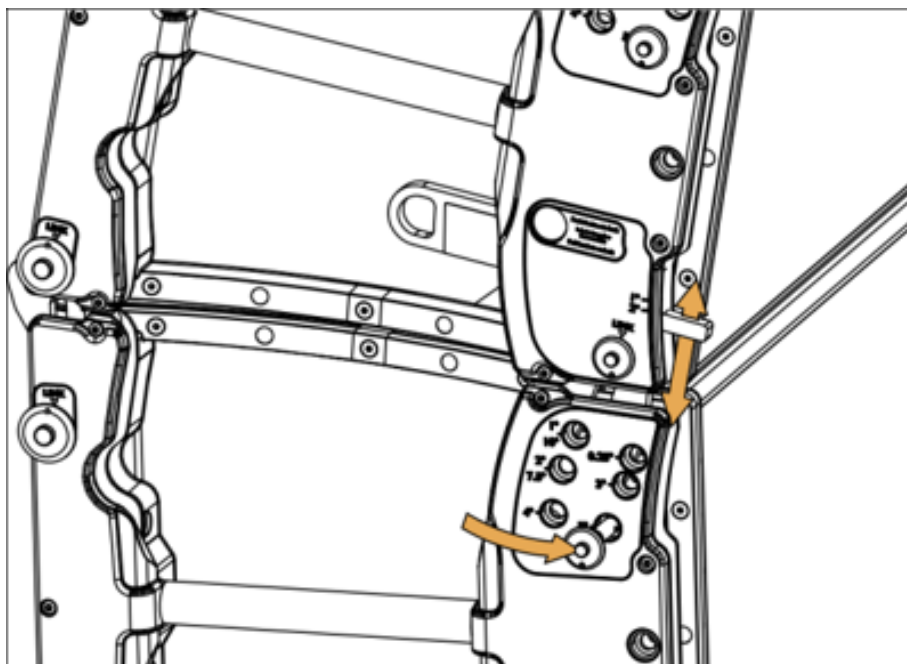

3. Press the lock button to lock the inter-enclosure angle.

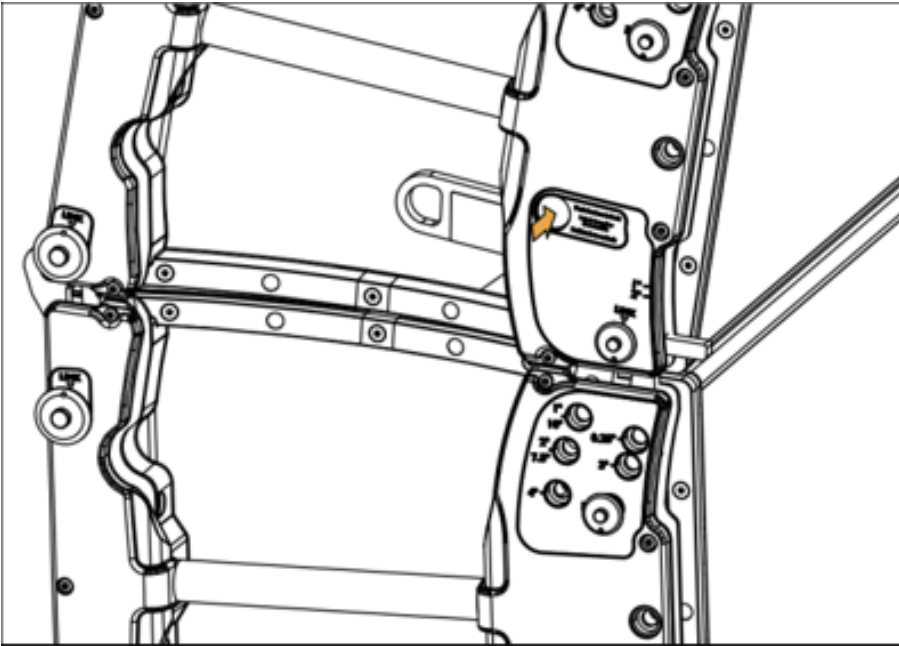

C - Attaching K2-JACK stabilizers to K2-CHARIOT

! **K2-JACK stabilizers storage position on K2-CHARIOT**
 K2-JACK stabilizers can be attached to K2-CHARIOT during storage.

i The K2-JACK stabilizers must not overlap on the wheel stops.
 They would prevent efficient stacking of K2-CHARIOT in storage.

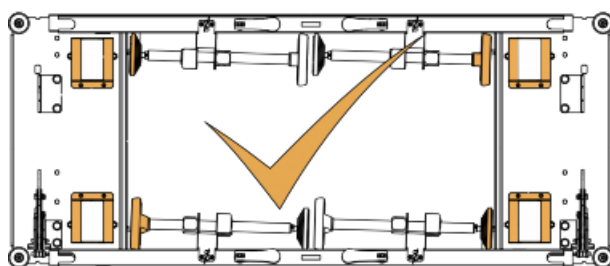
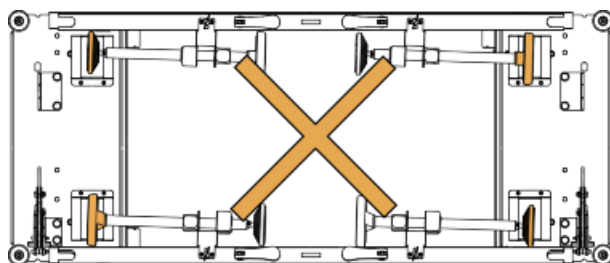

Tighten the bolts so the stabilizers do not move during transportation.

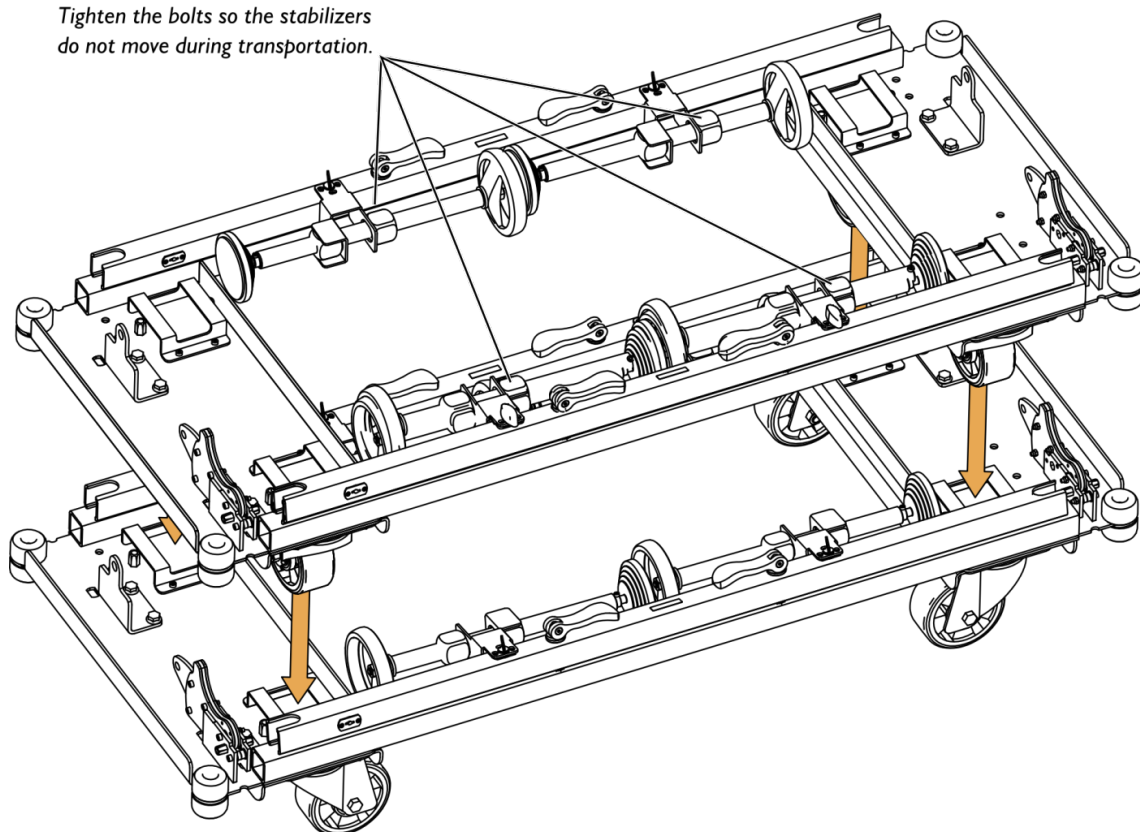

Procedure

1. Remove the two K2-JACK from the K2-CHARIOT:
 - a) Remove the stabilizers from each bar.

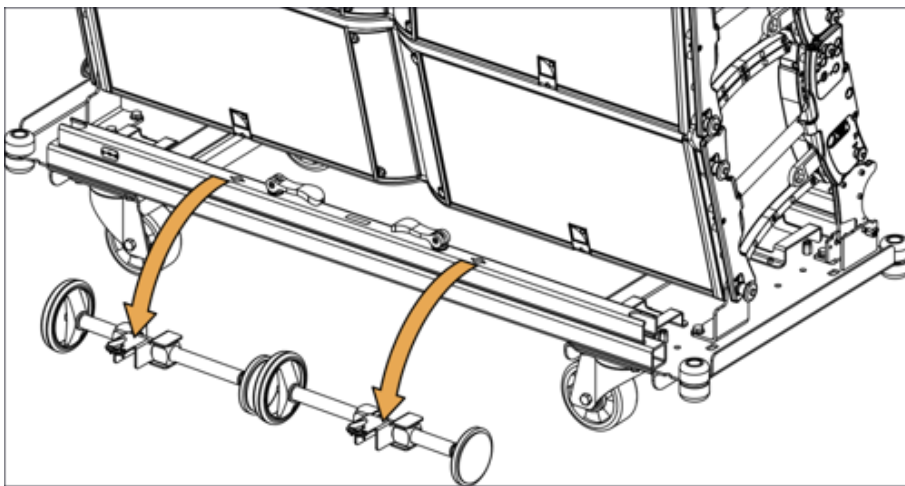
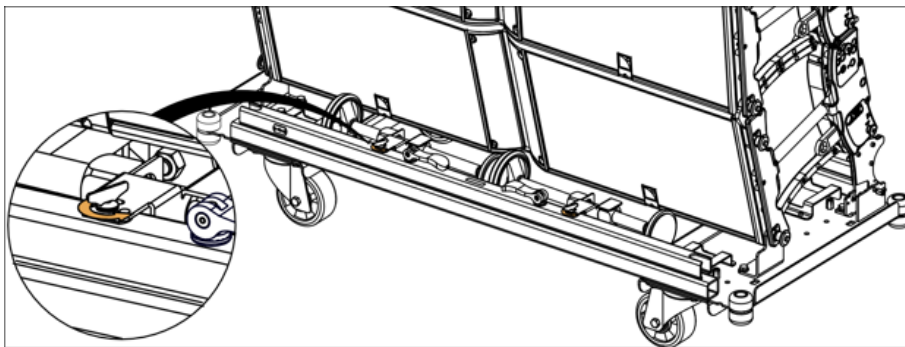

- b) Remove the bar from the K2-CHARIOT.

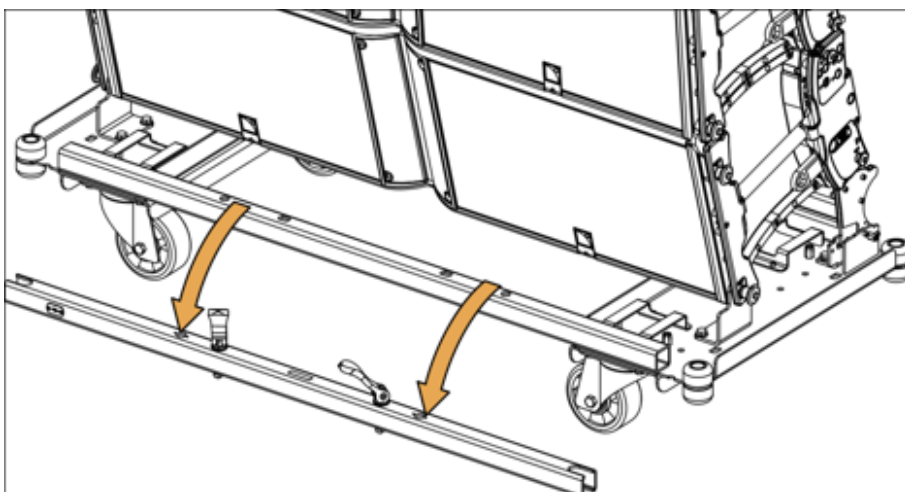
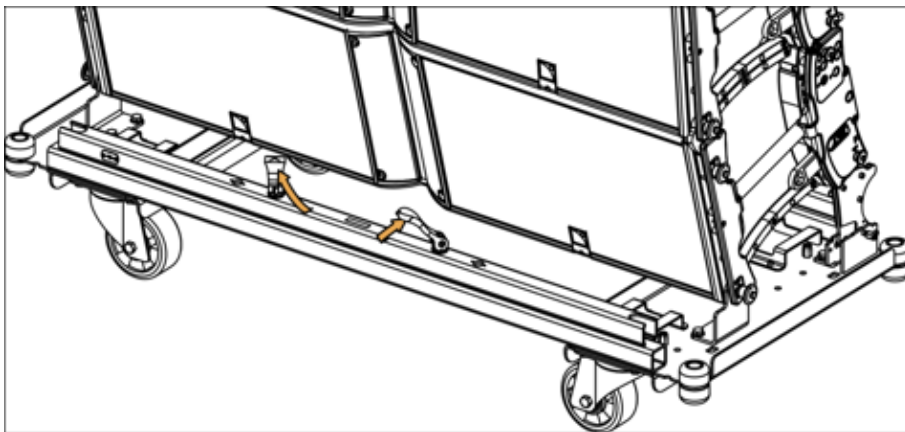

2. Attach the K2-JACK to the K2-CHARIOT:
 - a) Insert the K2-JACK studs through the K2-CHARIOT.

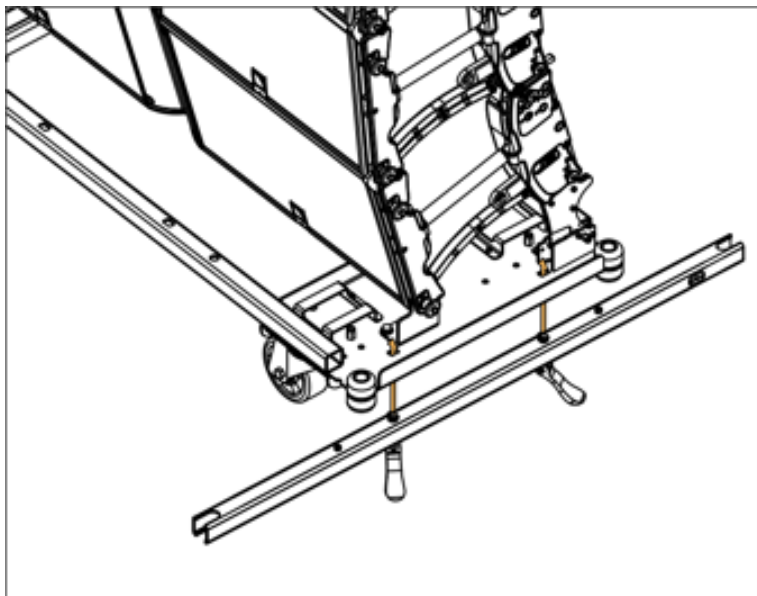

- b) Raise and turn the K2-JACK handles to secure the locking system.

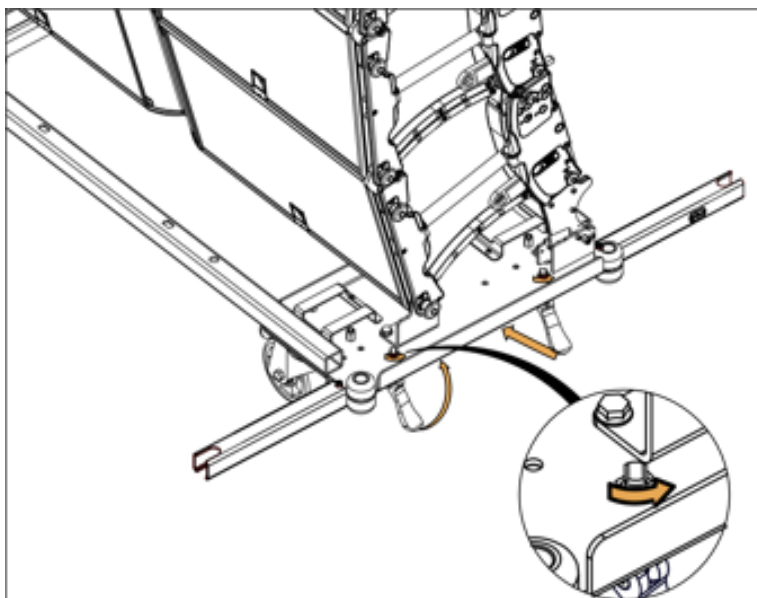

i **Dust**

During the K2-JACK stabilizers first use dust will come off the threaded rod. It is expected and does not indicate a malfunction.

3. Prepare the K2-JACK stabilizers.

Rotate the threaded rod counter-clockwise so the central part of the stabilizer is closest to the base.

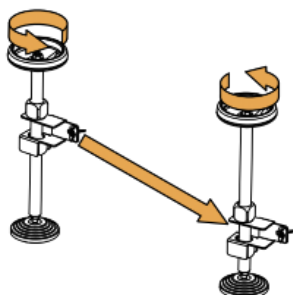

4. Attach the stabilizers to the bar.

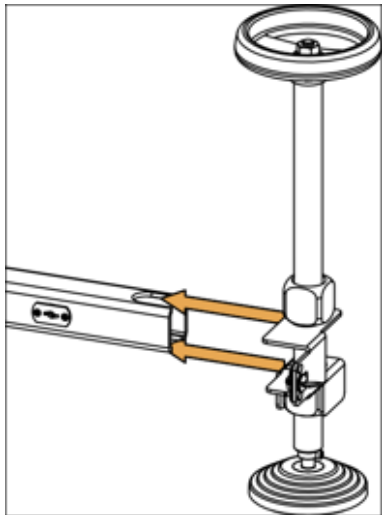

Insert the feet in the guides at both ends of the bar.

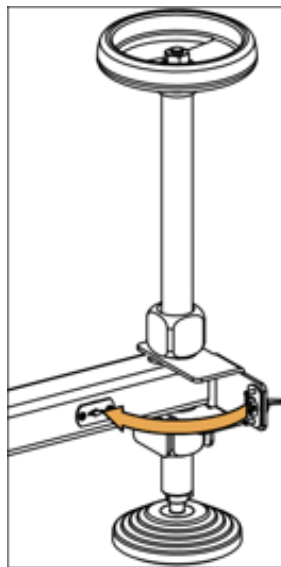

Pivot the feet so they come in contact with the bar.

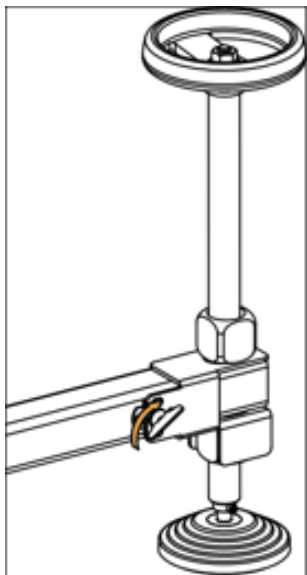

Lock the feet in position by giving a quarter-turn to the locking system.

5. Rotate the feet clockwise to raise the K2-CHARIOT off the ground.
Stop raising the stack as soon as the wheels get off the ground.

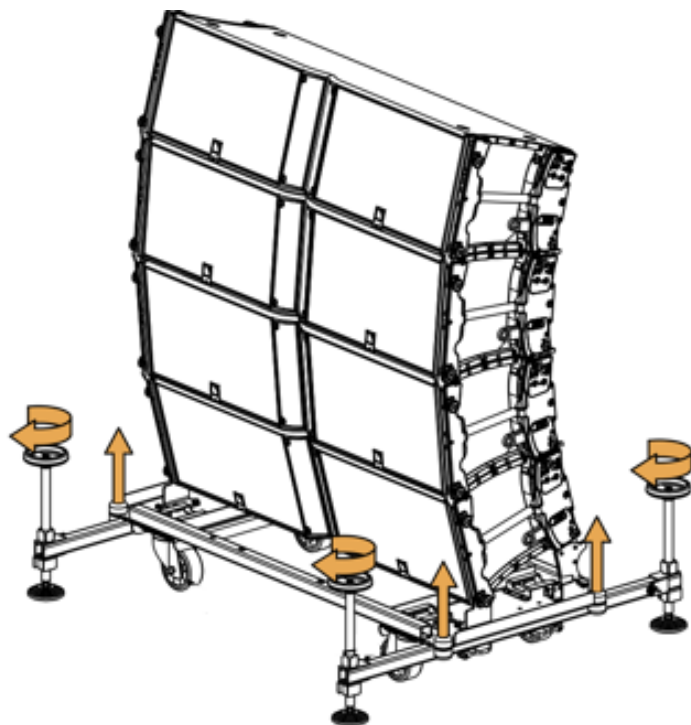

D - Changing the position of the K2-CHARIOT rear rigging arm

min number of operators	2
-------------------------	---

Procedure



Tipping hazard

When the rear rigging arms are unpinned, hold the enclosures on both sides.

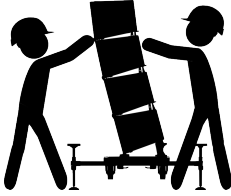

1. On both sides, remove the rear rigging arm pin.

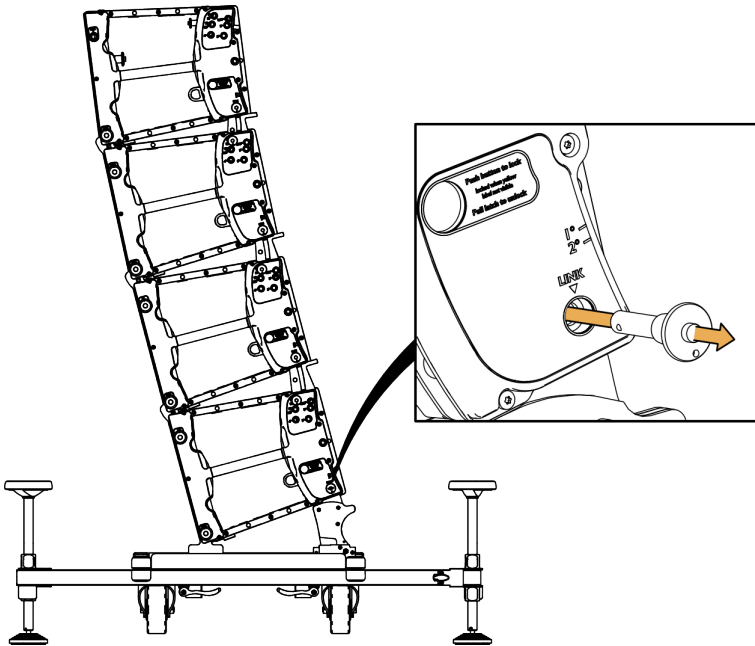

2. Push the enclosures to free both arms.

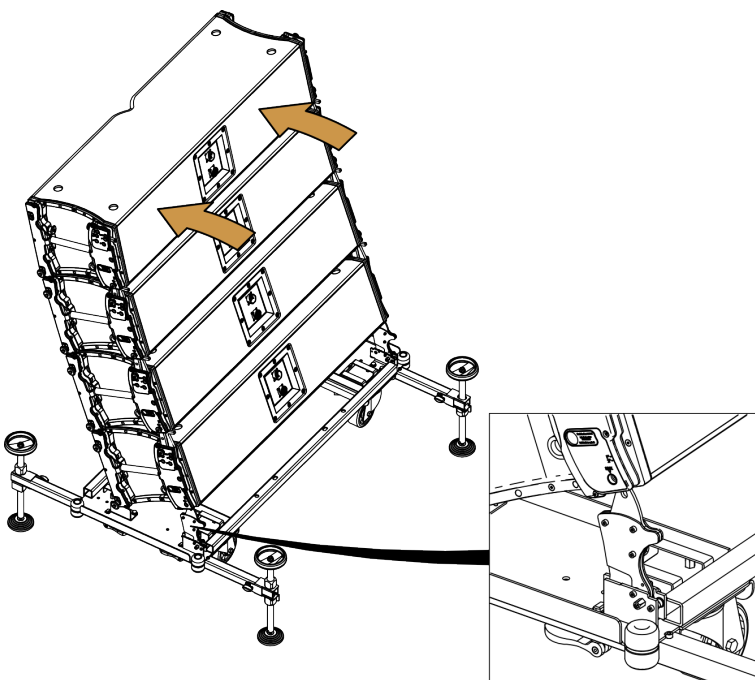

3. Use your foot to move up or move down the rear rigging arms.

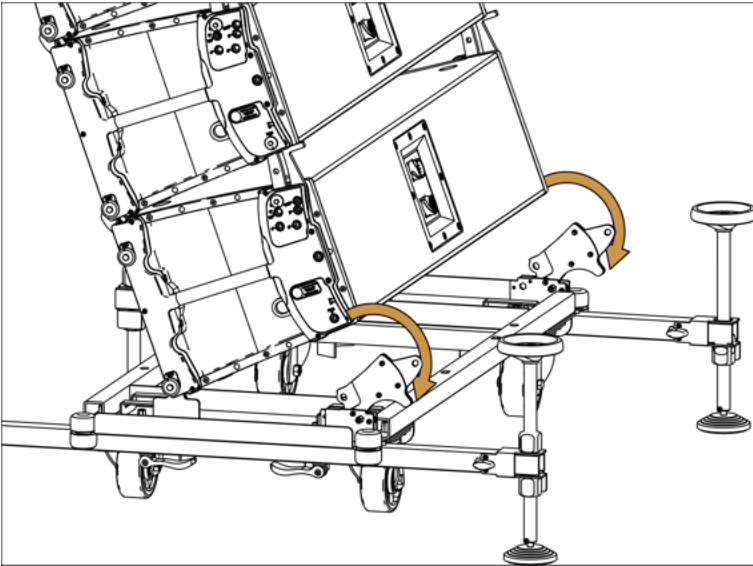

4. Guide the enclosures back on the arms.

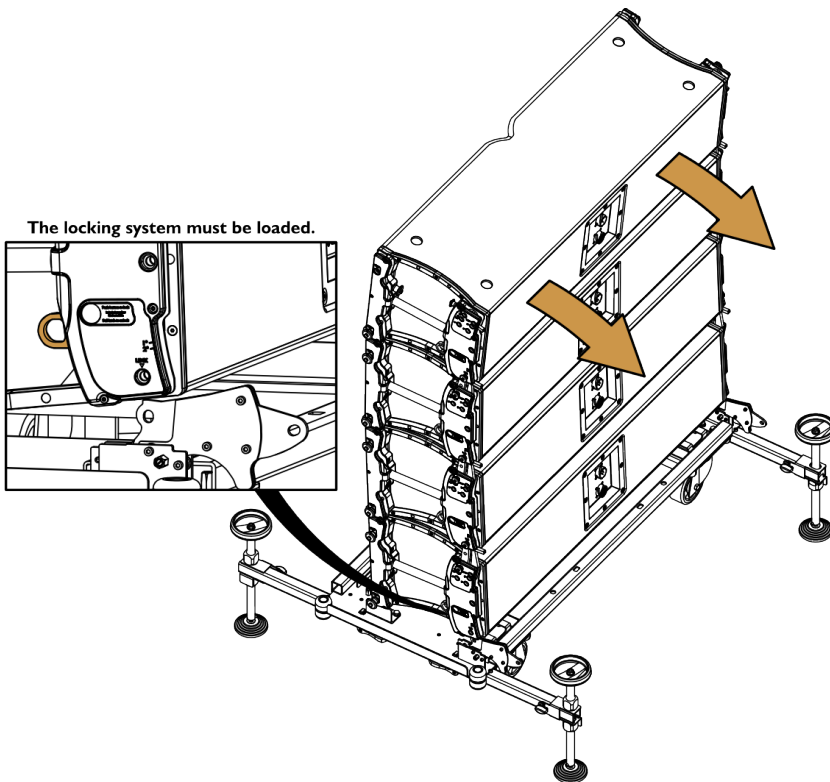

5. Pin the arms.

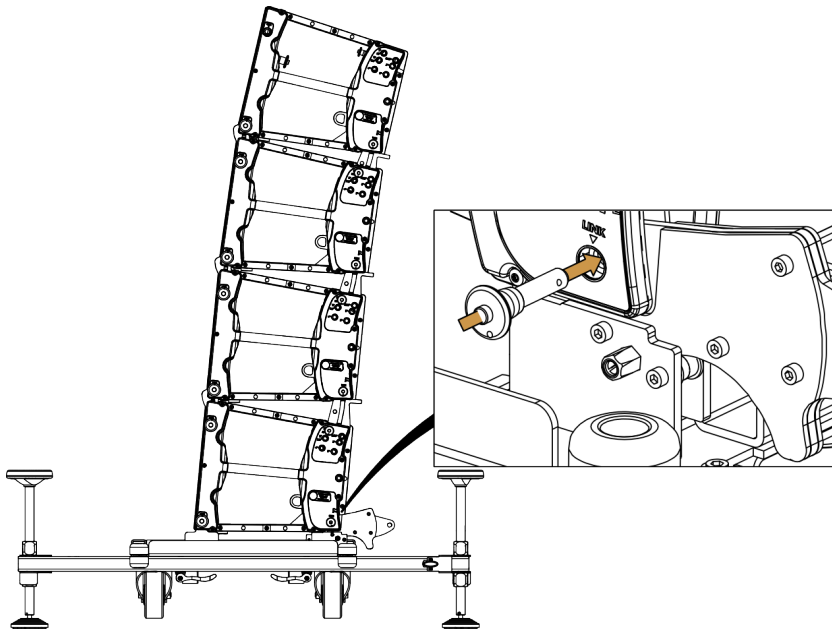

E - Adjusting the K2-CHARIOT site angle

Procedure

1. Verify the wheels are as close as possible to the ground without touching it.

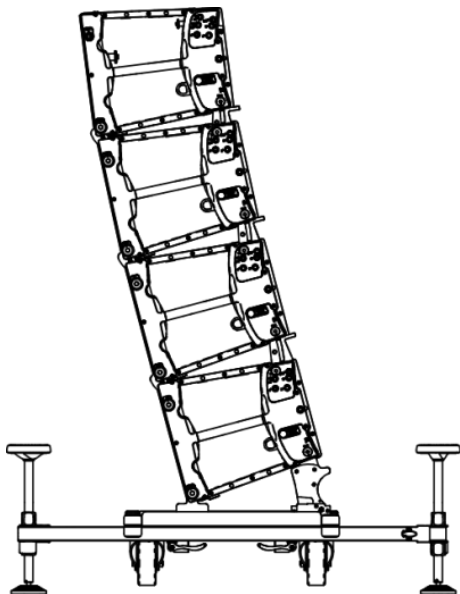

2. Loosen one stabilizer bolt and tighten the other one depending of the target site angle.



Tighten the bolt by hand only.

Negative site angle

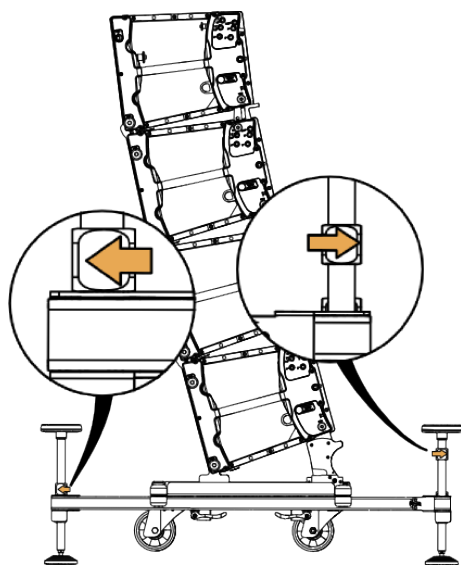

Positive site angle

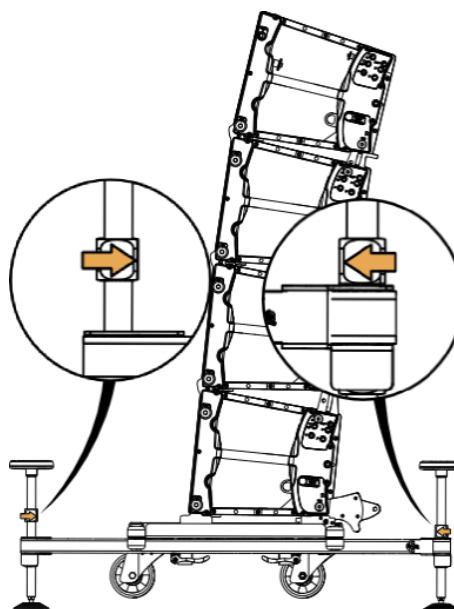

3. Adjust the site angle:



Tipping hazard

Adjust either the stabilizer at the front or at the back of the stack. Do not adjust both the front and back of the stack.

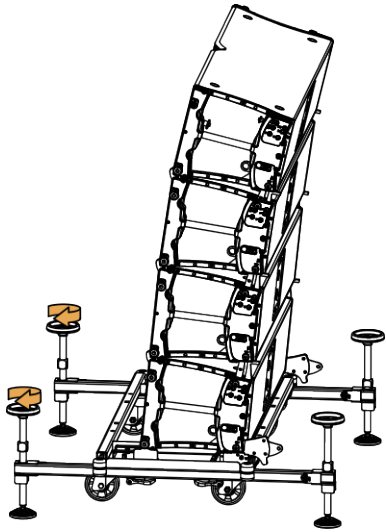

With the front screw jacks for a positive site angle.

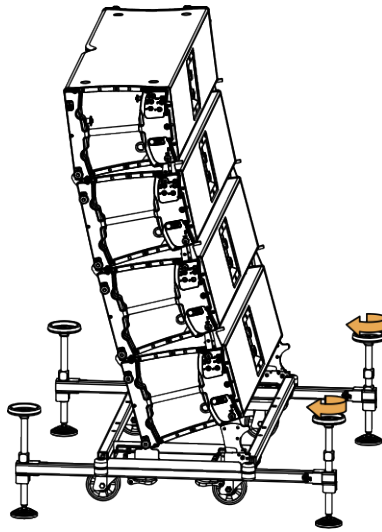

With the back screw jacks for a negative site angle.

4. Tighten the front or back bolts depending on the site angle.



Tighten the bolt by hand only.

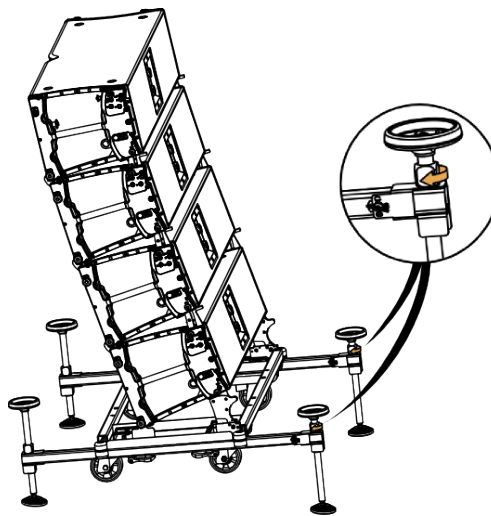
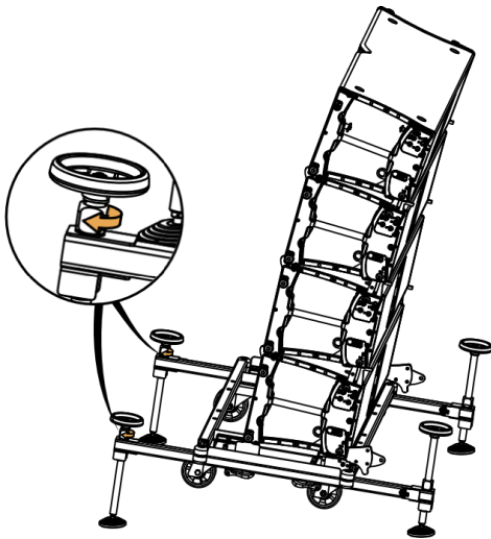

F - Stacking K2 on K2-BUMP

min number of operators	2
--------------------------------	---

Procedure

1. Prepare a block of 4 K2. Refer to [A - Preparing a block of 4 K2](#) (p.69).
2. Preset the inter-enclosure angles. Refer to [B - Preset the inter-enclosure angles](#) (p.73).
3. Prepare the K2 block top enclosure:
 - a) Take out and lock the rear and front rigging arms.

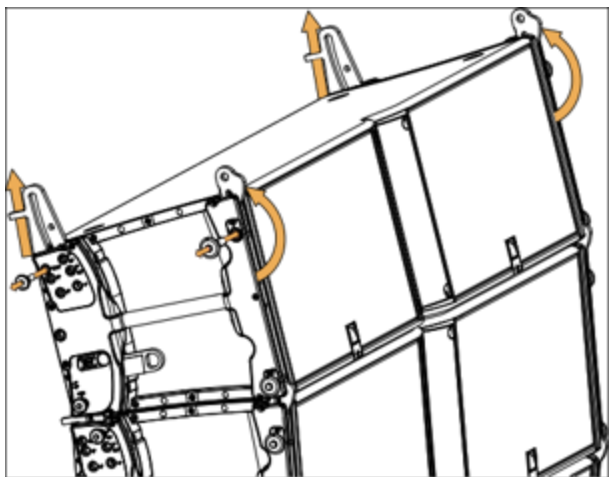

- b) Define the K2 stack site angle with the rear rigging arm.
 For the top enclosure of the stack, select a value between 0.25 and 7.5 and subtract 3 to obtain the final site angle. For the other enclosures, select the angle normally.

Final site angle for top enclosure

authorized angles	final site angles
0.25°	-2.75°
1°	-2°
2°	-1°
7.5°	4.5°
3°	0°
4°	1°
5°	2°

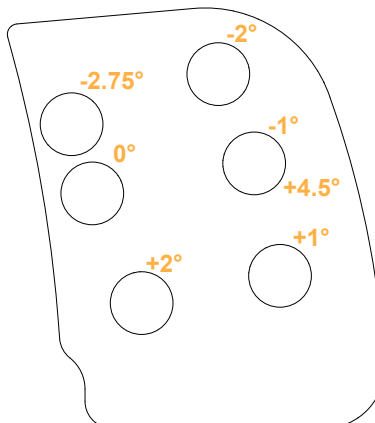
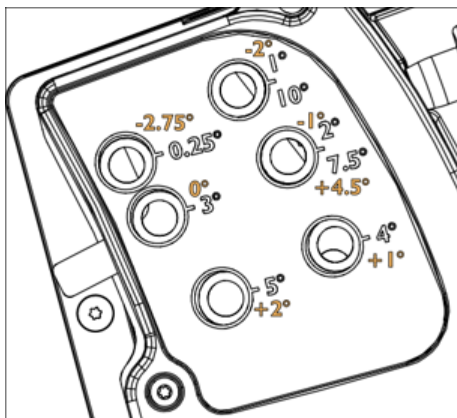

4. Remove the lower rear and front pins.

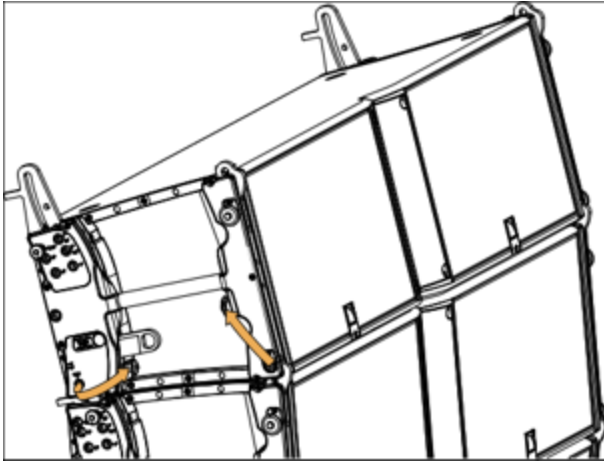

5. Turn the enclosure upside down on the K2-BUMP:

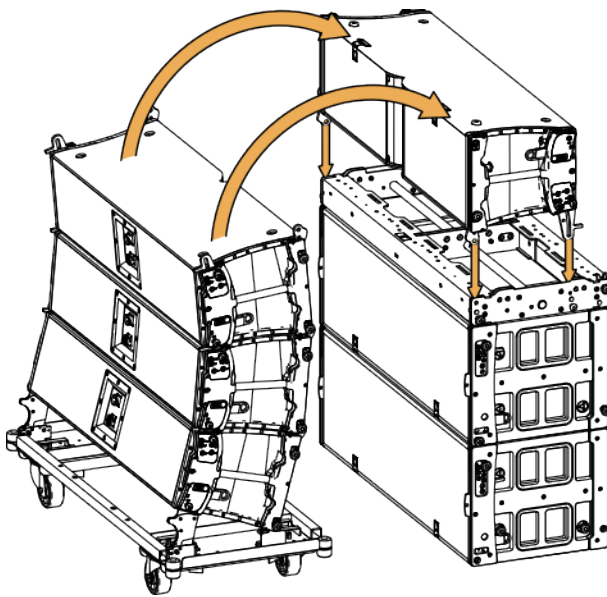

- a) Attach the K2 enclosure upside down on the K2-BUMP.

i The rigging arms should rest on the K2-BUMP spacers.

- b) Secure the rear arm to the K2-BUMP.

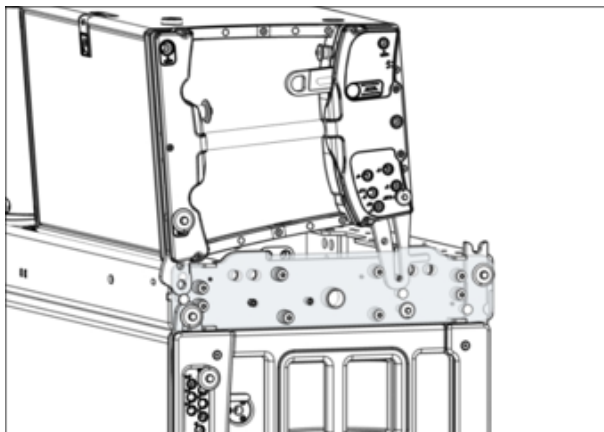

- c) Slide the front arm up and down to align the holes and secure it. Attach the front arm to the K2-BUMP.

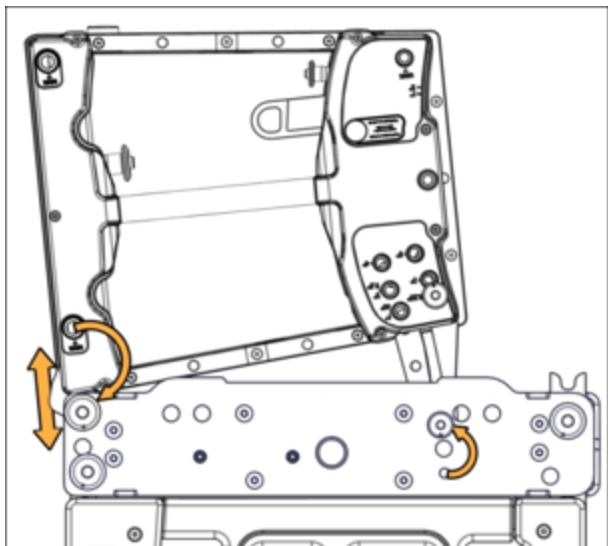

- d) Raise the top enclosure to align the holes. Secure the front rigging arm. Push the locking system button to arm the latch.

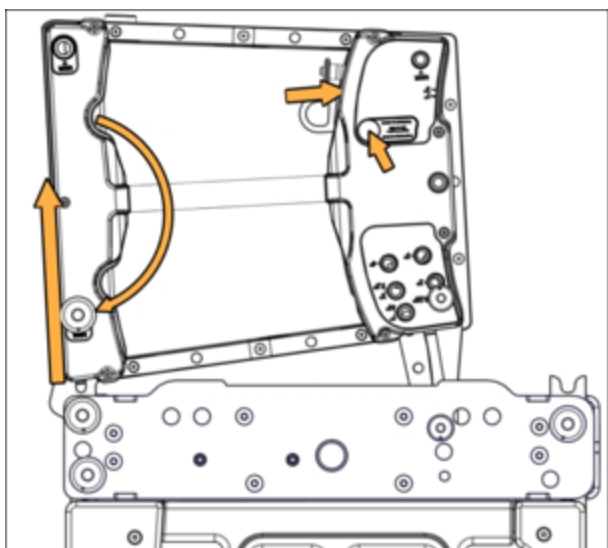

6. Attach another upside down K2 enclosure on the assembly:

- a) Secure the rear arm to the lower K2 enclosure.

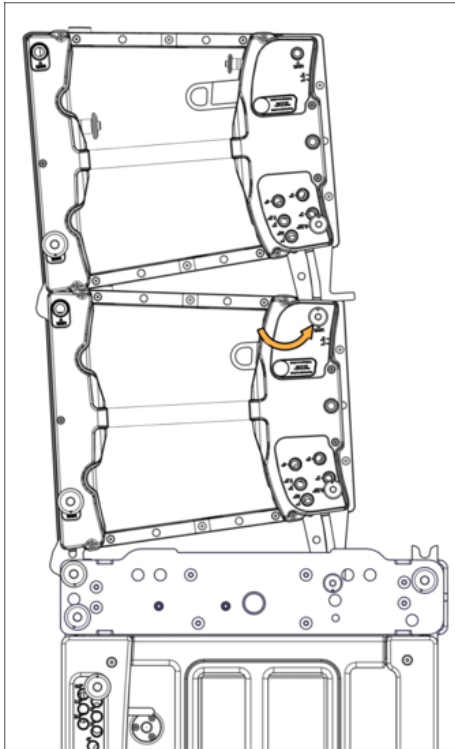

- b) Slide the front rigging arm up and down to align the holes. Attach the front arm to the lower K2 enclosure.
- c) Raise the top enclosure to align the holes. Secure the front rigging arm. Push the locking system button to arm the latch.

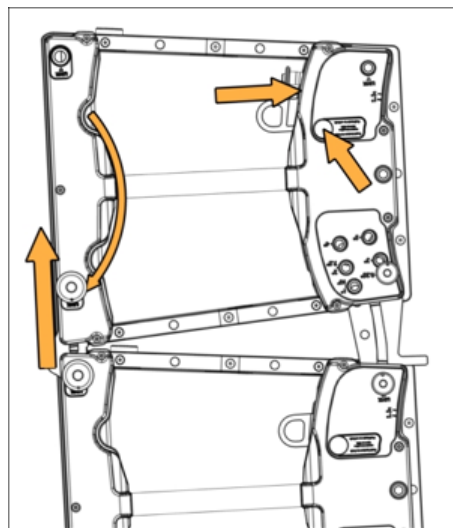
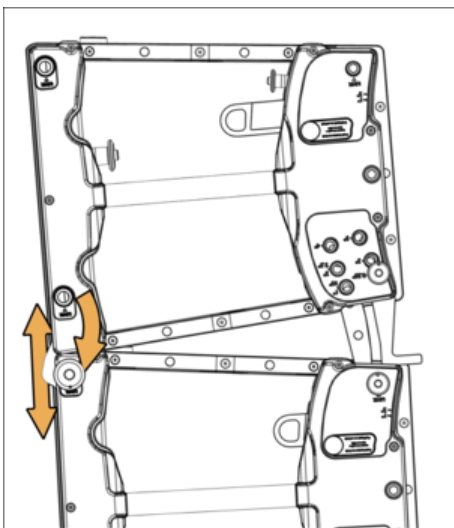

G - Attaching K2-BAR to K2-BUMP

Procedure

1. Refer to your Soundvision model to identify the extension and position of the bar.

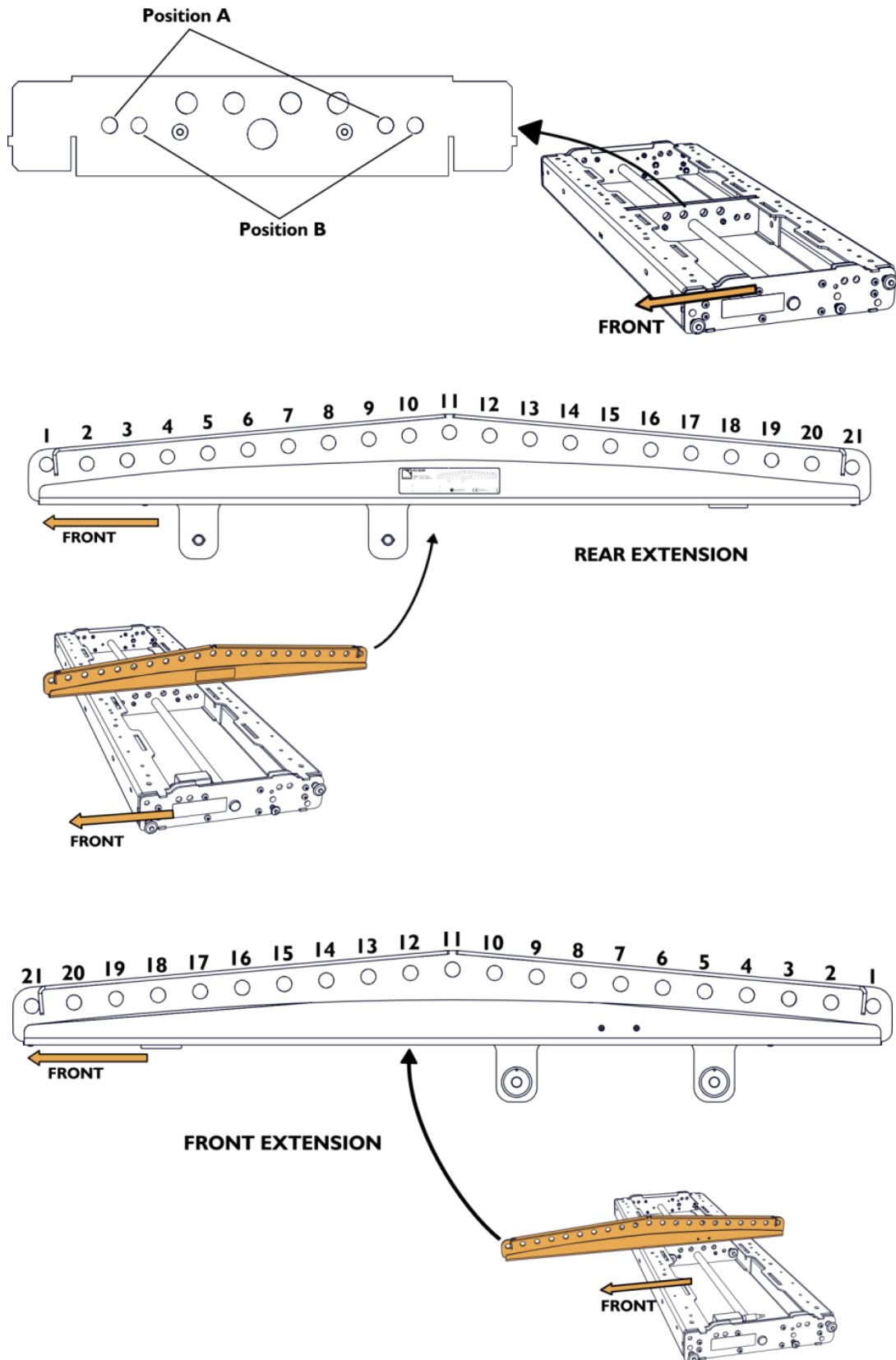

2. Remove the pins and lift the K2-BAR using the motor.

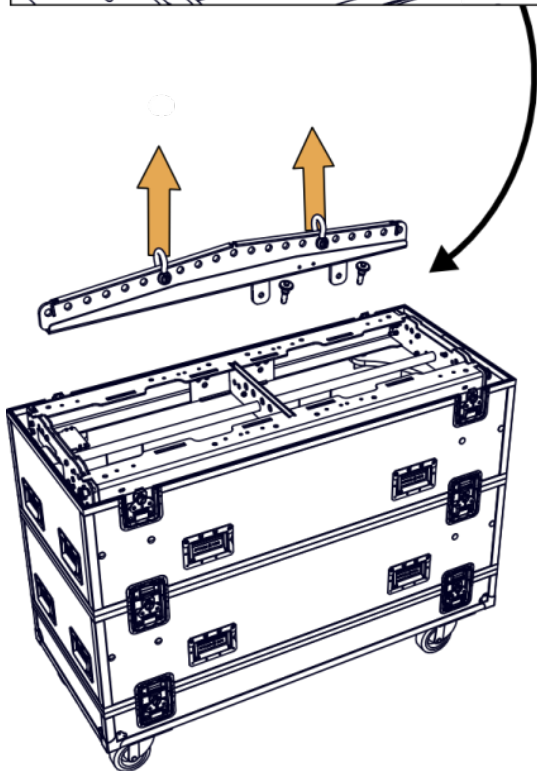
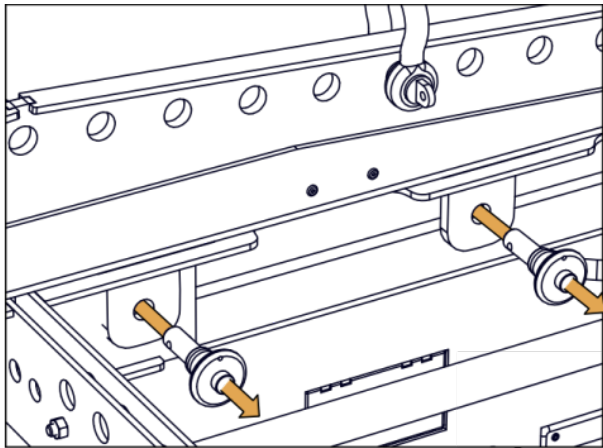

3. Turn the K2BUMPFLIGHT 90°, lower K2-BAR and pin it according to the chosen flying option (position A or B, in front or rear extension).

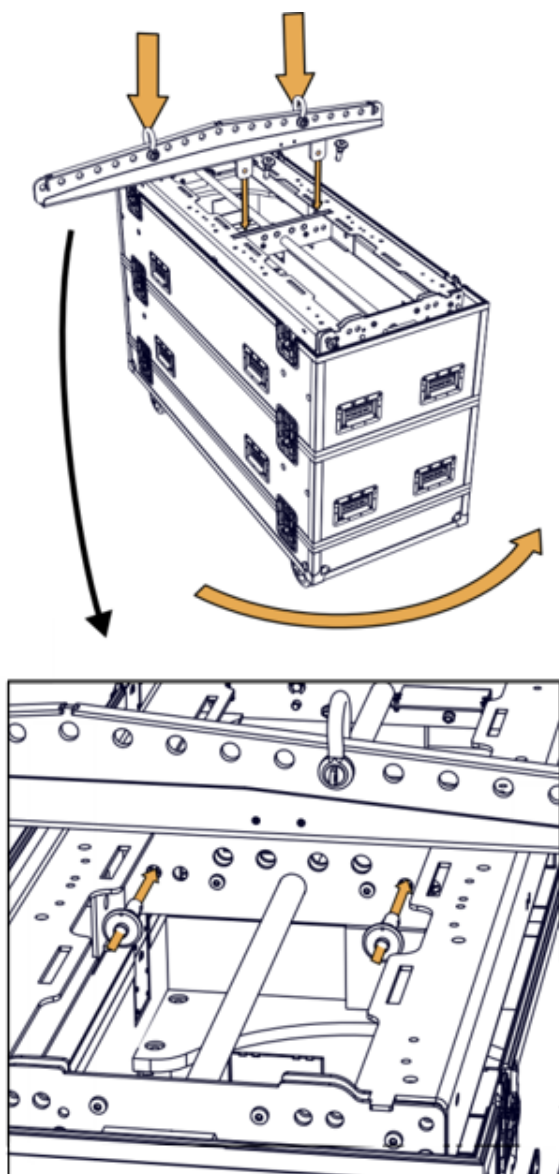

H - Attaching a block of four K2 under K2-BUMP

min number of operators	2
-------------------------	---

Procedure

1. Lower the K2-BUMP to allow for front connection.



Preset inter-enclosure angles

Preset the inter-enclosure angles before performing this procedure. Refer to [B - Preset the inter-enclosure angles \(p.73\)](#).

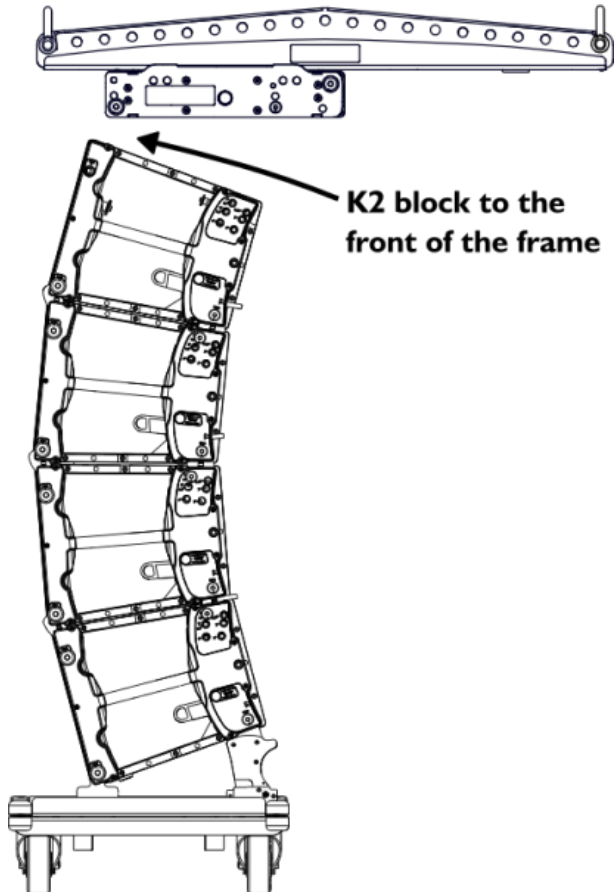

- 2.** Attach the front rigging arm on both sides:
a) Rotate the arm and secure it with the K2-BUMP pin.

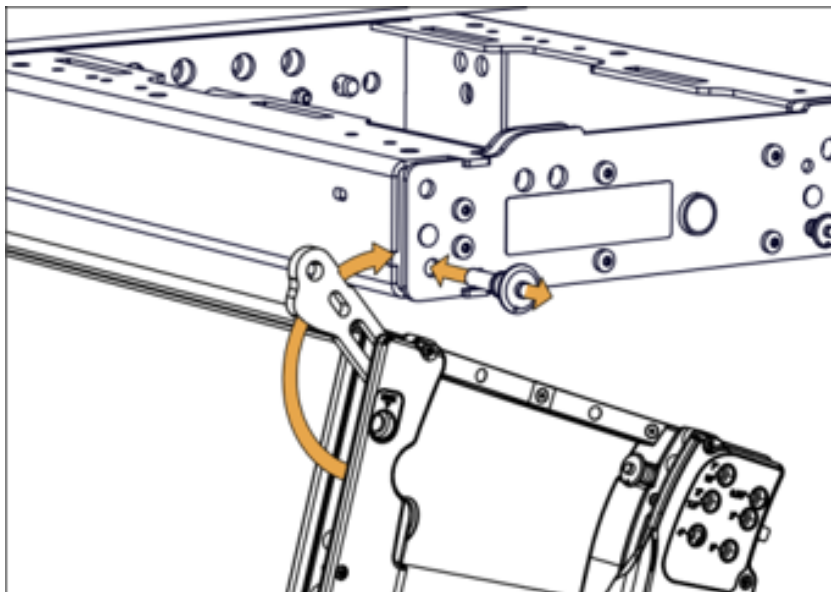

- b) Lower the K2-BUMP and secure the connection with the K2 pin.
If you cannot insert the pin, move the frame back and forth.

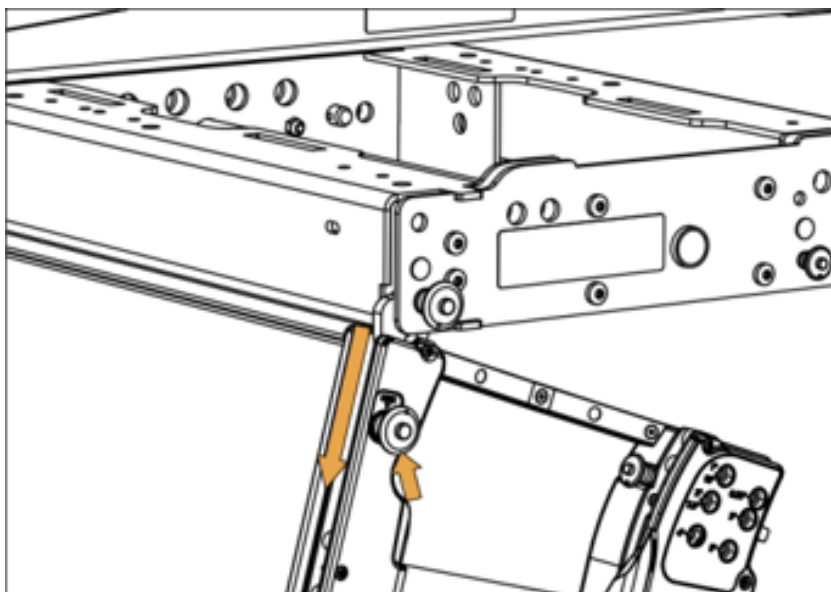

3. Lower the rear of the K2-BUMP.

! Do not lower until contact. Leave a gap allowing to slide the K2 arm to its 5° position.

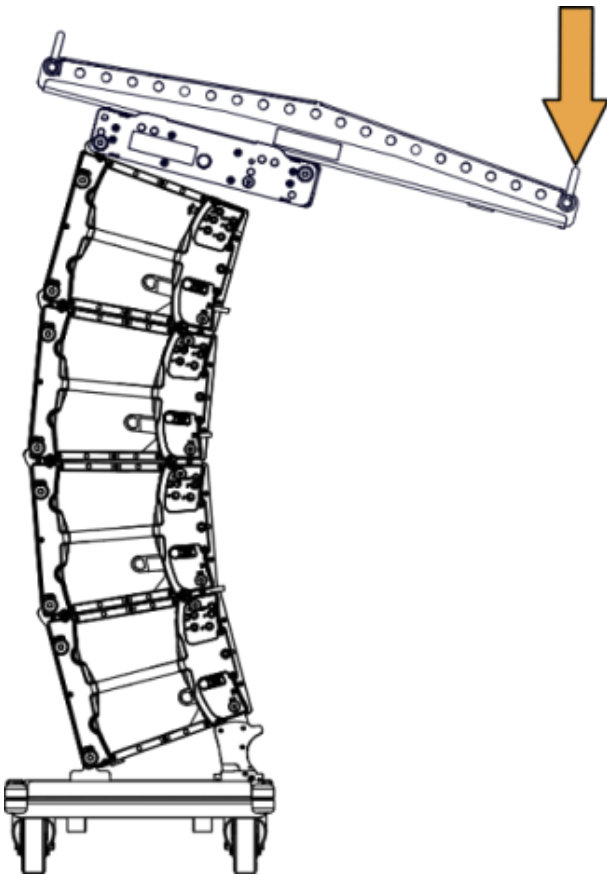

4. Attach the rear rigging arm to the frame:

- a) Slide the arm to its 5° position.
- b) Preset the angle at 5° with the enclosure pin.
- c) Secure the arm with the frame pin.

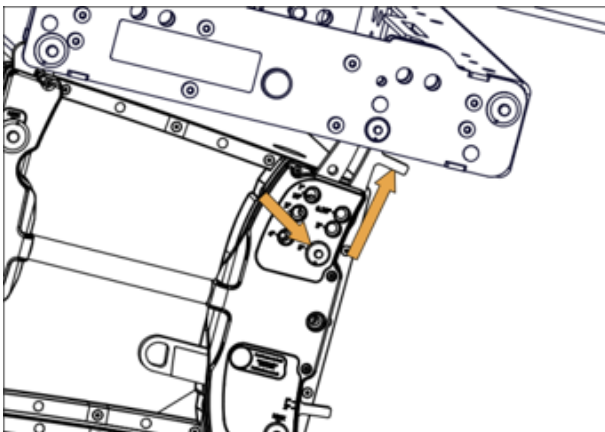

5. Raise the array to lock the inter-enclosure angles.

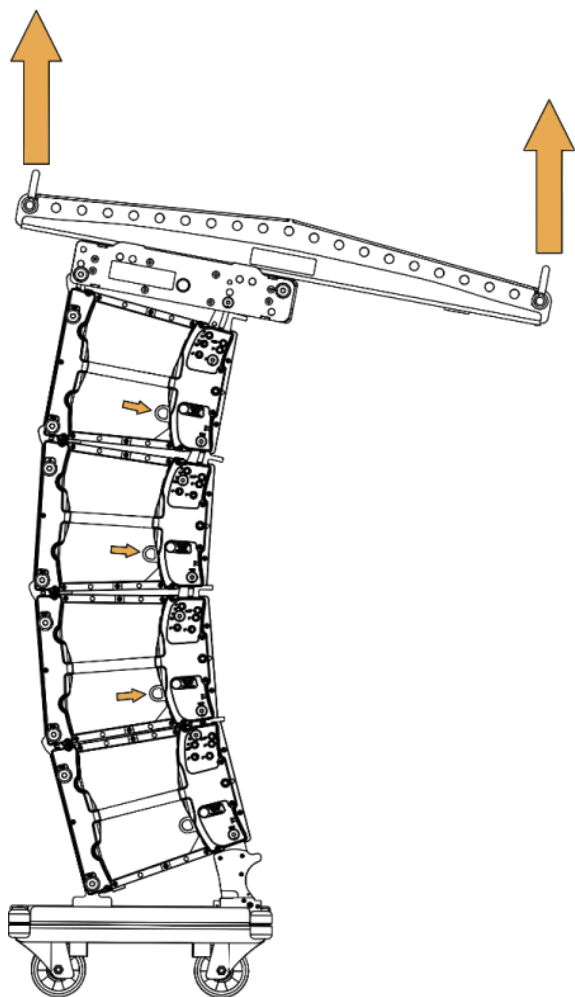

6. Remove K2-CHARIOT:

a) Hold the dolly with one hand. Remove the back pin on both sides.

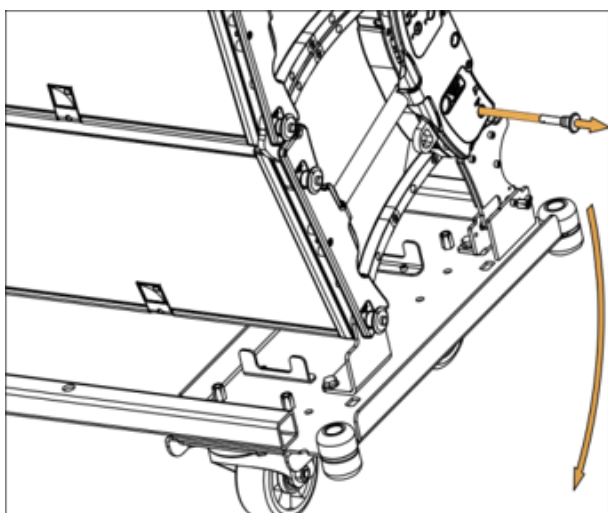

b) Hold the dolly with one hand. Remove the front pin on both sides.

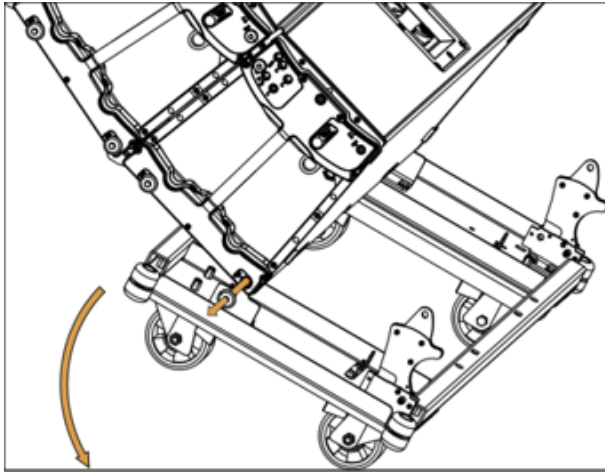

I - Attaching a block of four K2 under K2-RIGBAR

Procedure



Preset inter-enclosure angles

Preset the inter-enclosure angles before performing this procedure. Refer to [B - Preset the inter-enclosure angles](#) (p.73).

1. Hang the LA-SLING2T to the motor hook.



Make sure the chains are not twisted.

2. Attach the bar to the sling using the two 3.25 t WLL shackles. Use the interior holes of the bar.



The external holes are dedicated to safety slings.

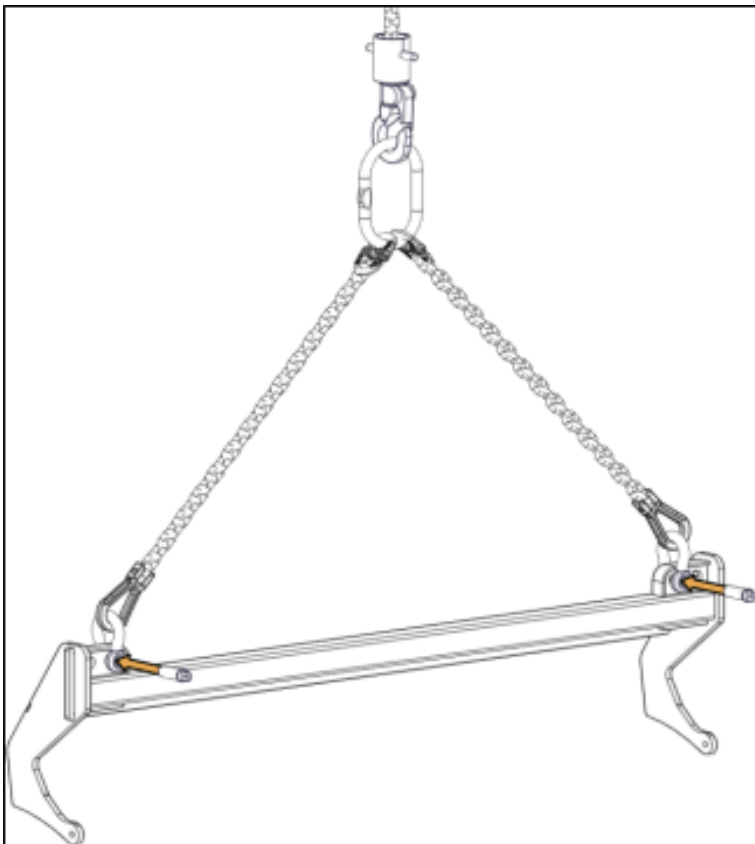

3. Position and attach the K2 enclosures under K2-RIGBAR.
Use the rear rigging middle hole.

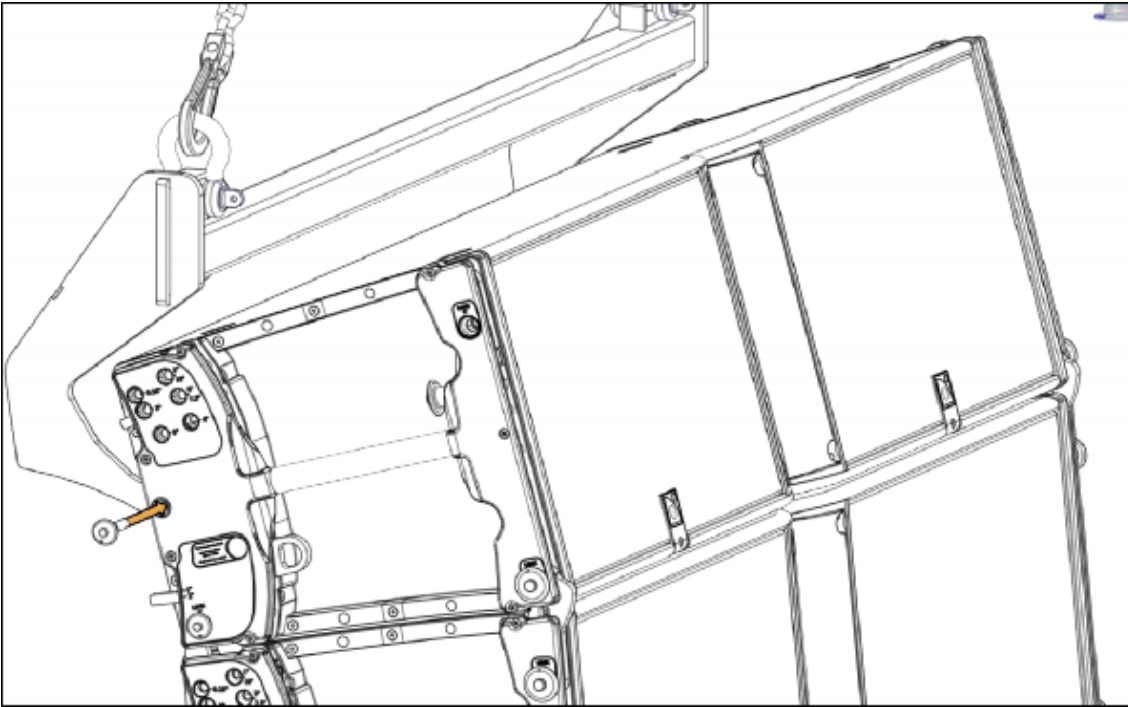

4. Raise the array to lock the inter-enclosure angles.



Do not stand behind the array

The array swings backwards when it is raised.

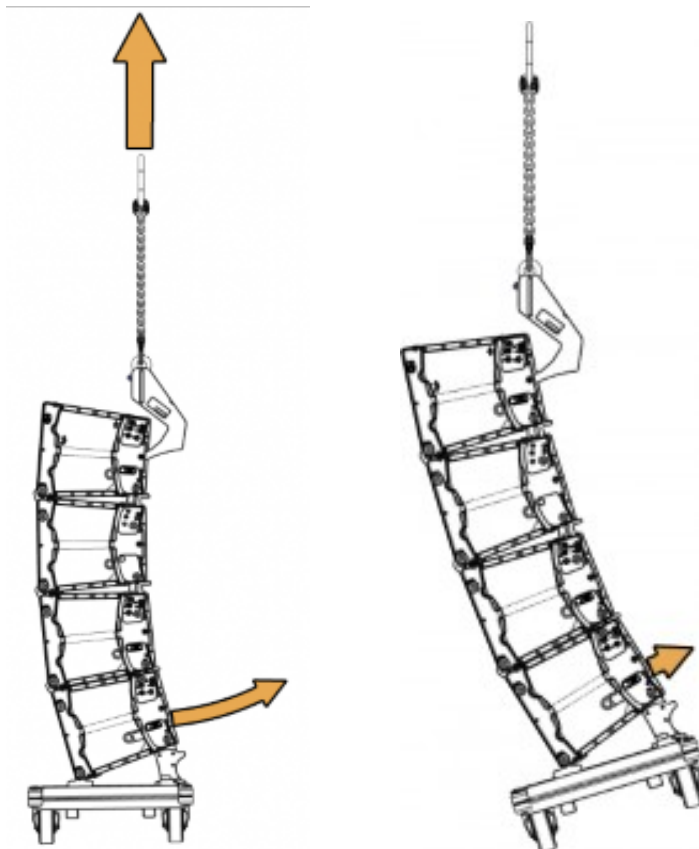

5. Remove the K2-CHARIOT:

- a) Hold the dolly with one hand. Remove the back pin on both sides.

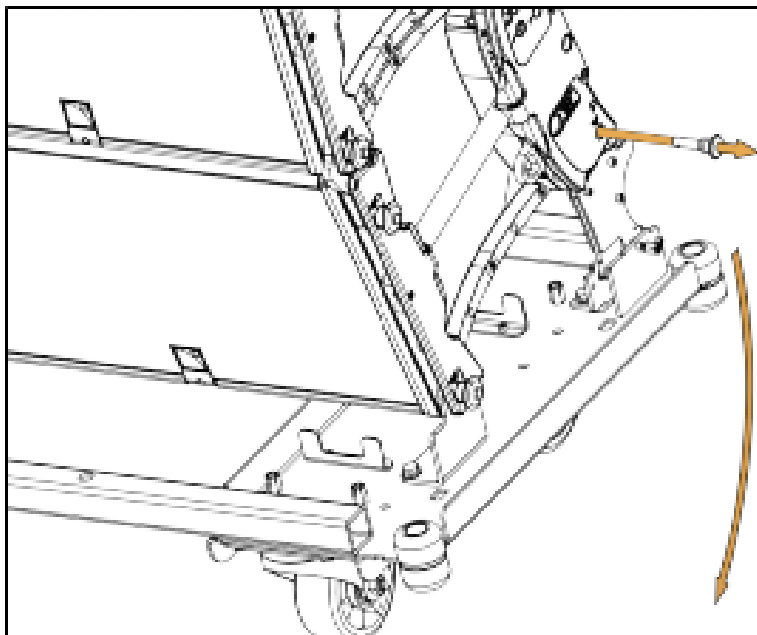

- b) Hold the dolly with one hand. Remove the front pin on both sides.

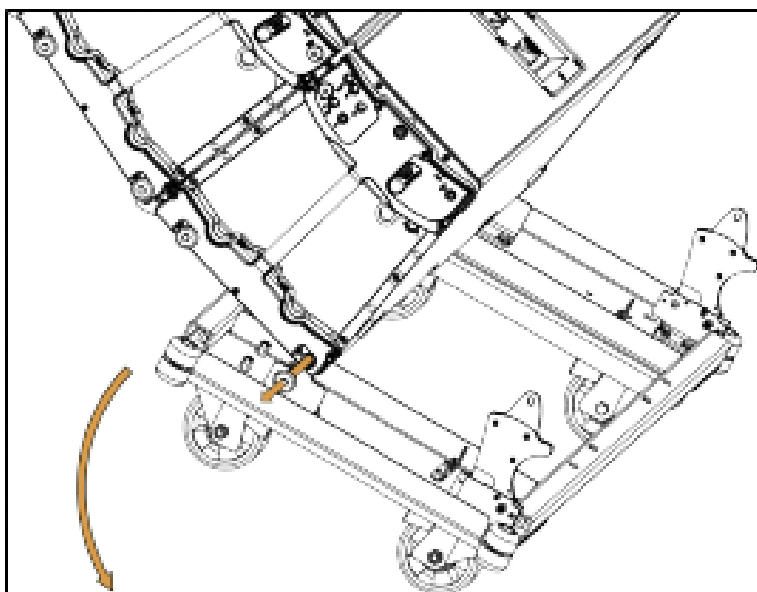

J - Attaching a block of four K2 under K2

Procedure



Preset inter-enclosure angles

Preset the inter-enclosure angles before performing this procedure. Refer to [B - Preset the inter-enclosure angles](#) (p.73).

1. Attach the front rigging arm on both sides:

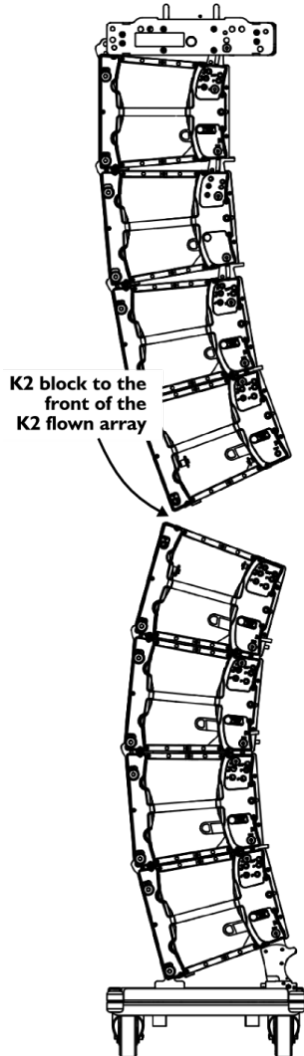

- a) Rotate the arm to align its hole with the K2 rigging hole.

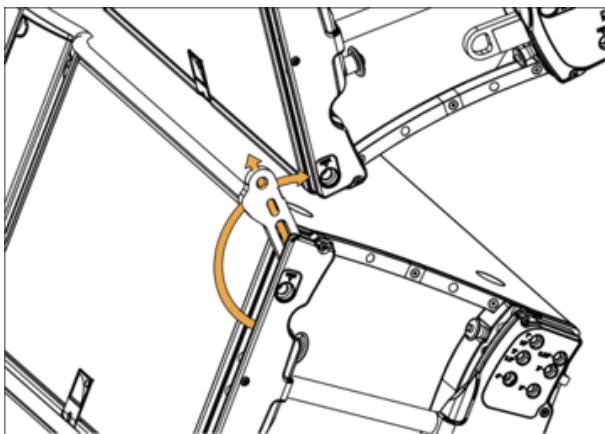

b) Pin the arm in the LINK hole of the flown array.

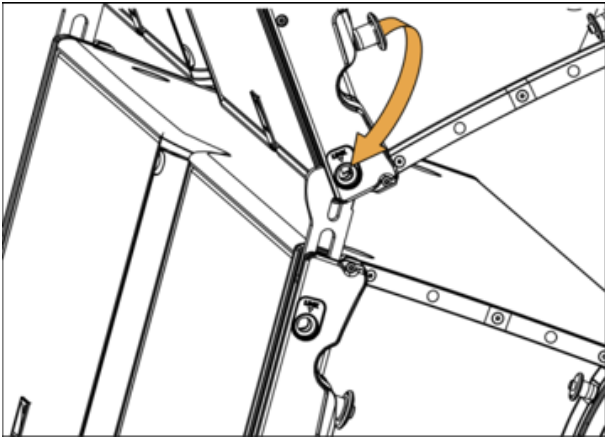

c) Lower the flown array and secure the assembly with the LINK pin.



If you cannot insert the pin, move the flown array back and forth with enclosure handle.

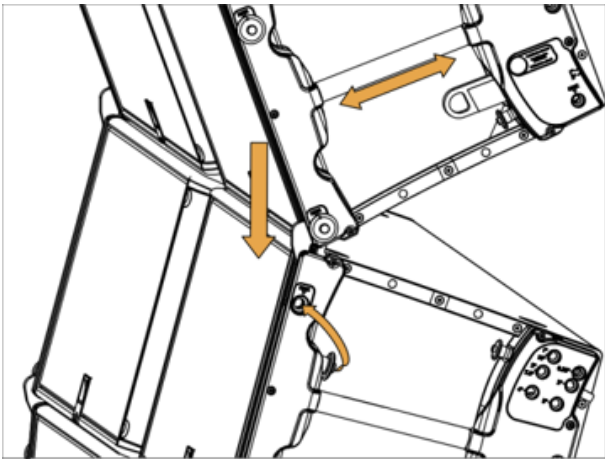

2. Lock the inter-enclosure angles of the block.

Raise the array.

The lower K2 enclosures swing and the latches automatically lock.

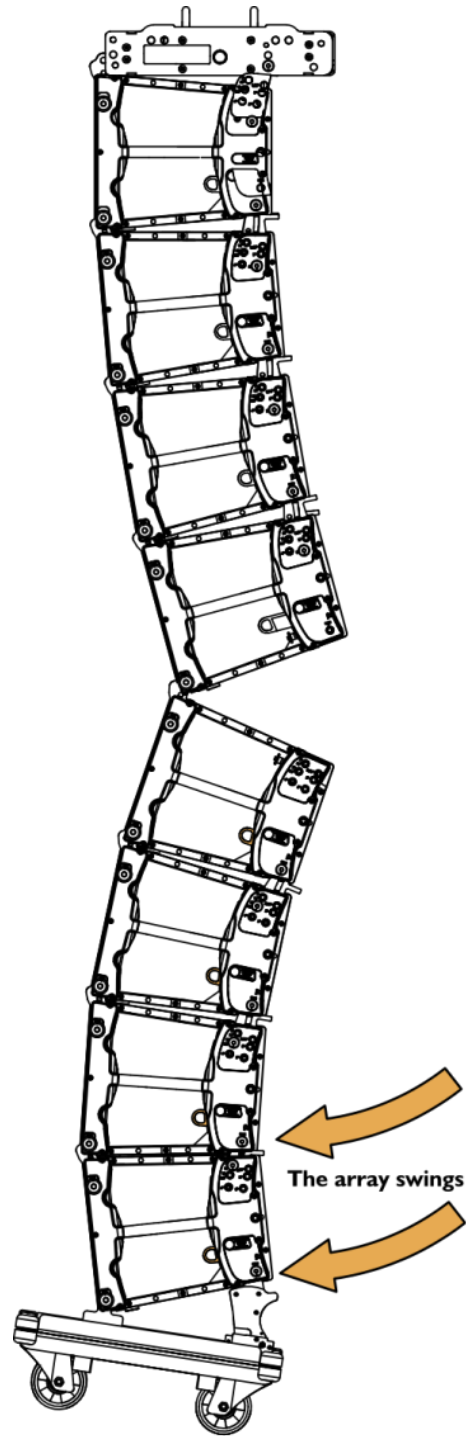
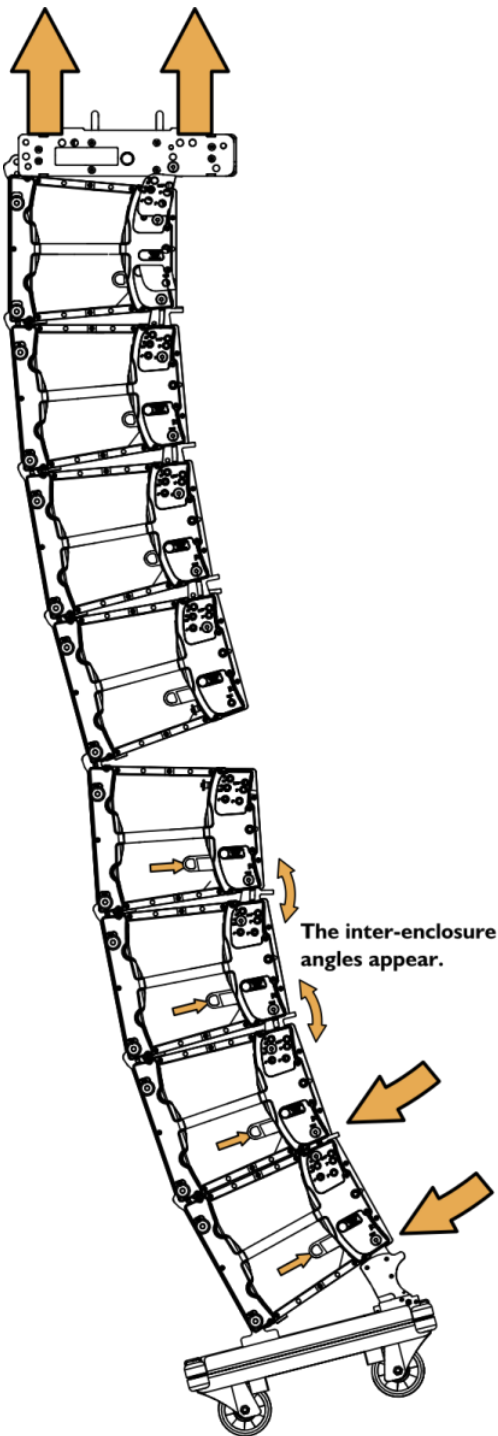

- 3.** Attach the lower K2 enclosures rear rigging arm to the back of the array:
a) Turn the wheels inside the dolly.

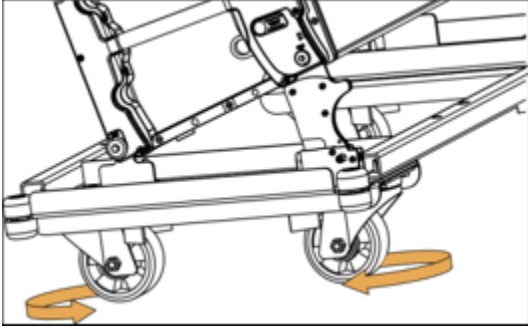

- b) Pull back the bottom enclosures while lowering the array until the array and the top enclosure of the block are in contact.

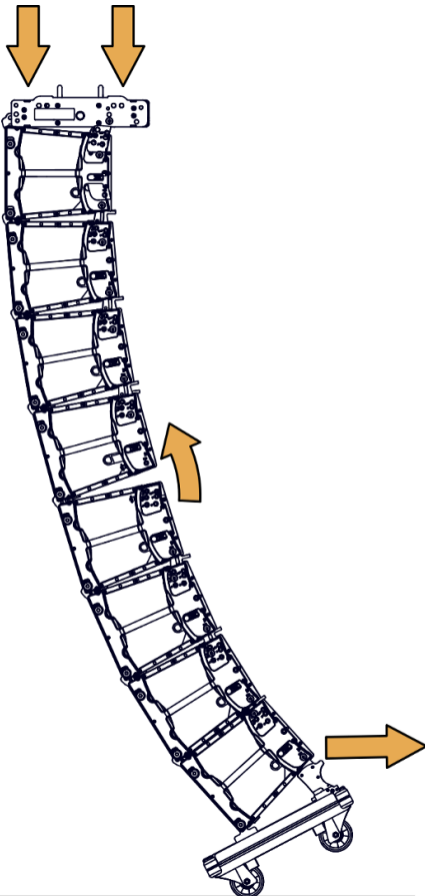

- c) Slide the arm upward and secure it with the pin using the LINK hole.

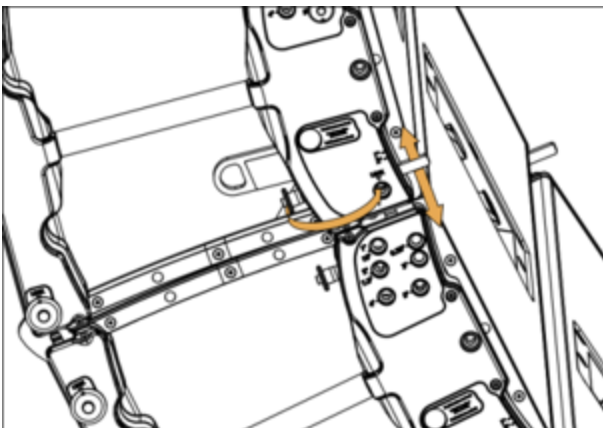

d) Position the pin at the entrance of the chosen angle hole and slide the rigging arm until the pin goes in.

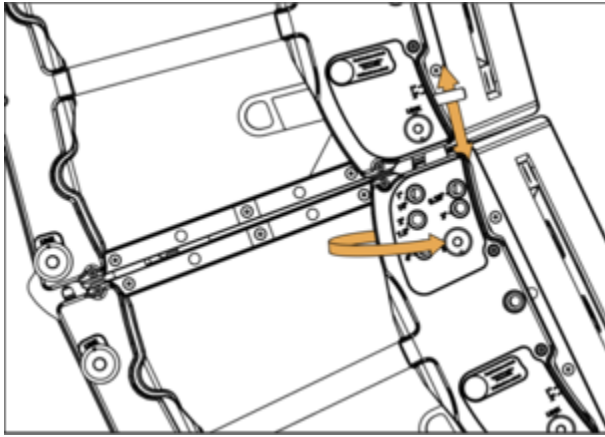

e) Press the lock button.

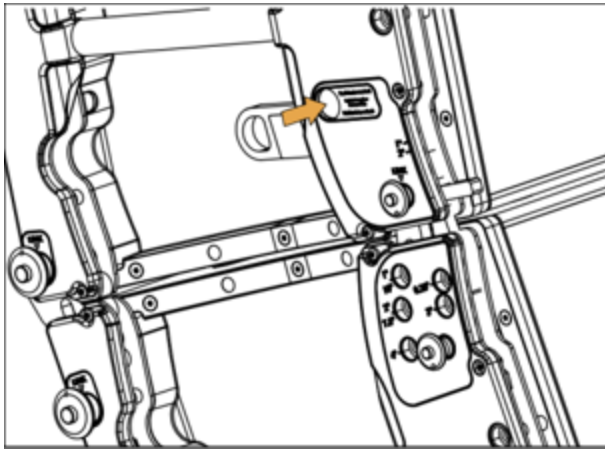

4. Raise the array to lock the inter-enclosure angle.
The latches automatically lock.

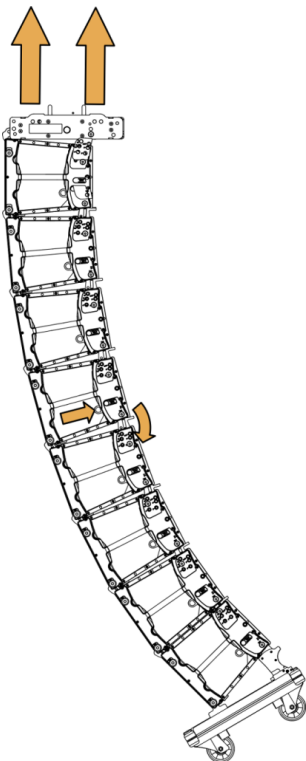

5. Remove the K2-CHARIOT:

- a) Hold the dolly with one hand. Remove the back pin on both sides.

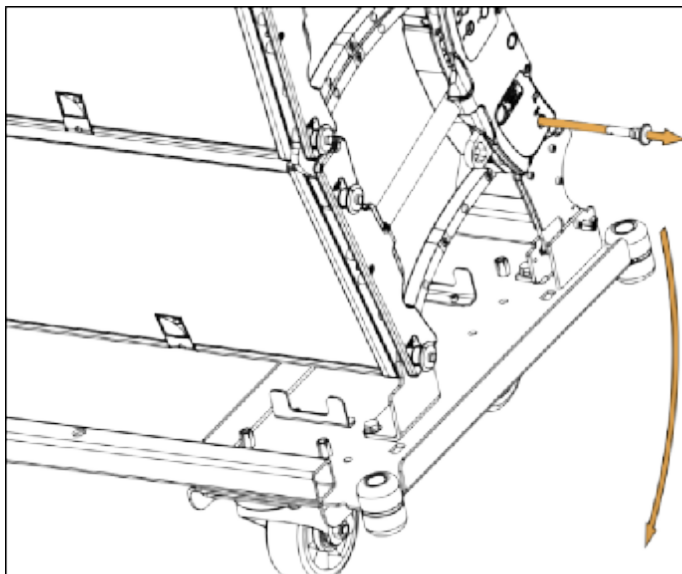

- b) Hold the dolly with one hand. Remove the front pin on both sides.

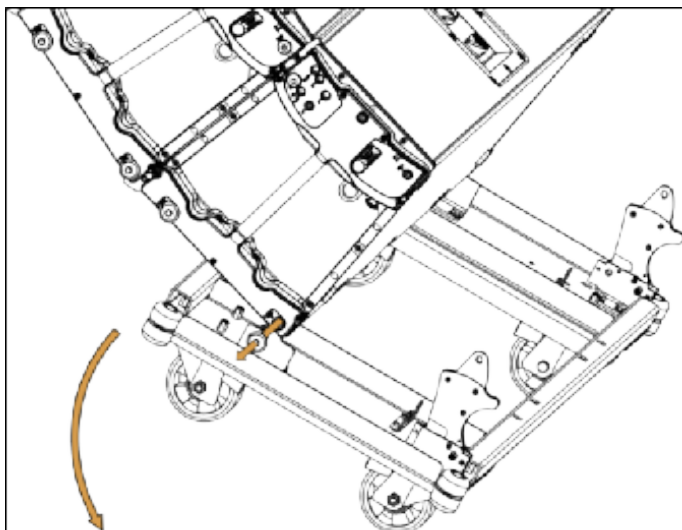

K - Attaching a block of four K2 under a K1 system element

Procedure



K1 / K1-SB must always be on top of a K2 array.



Preset inter-enclosure angles

Preset the inter-enclosure angles before performing this procedure. Refer to [B - Preset the inter-enclosure angles](#) (p.73).

1. Attach the front rigging arm on both sides:

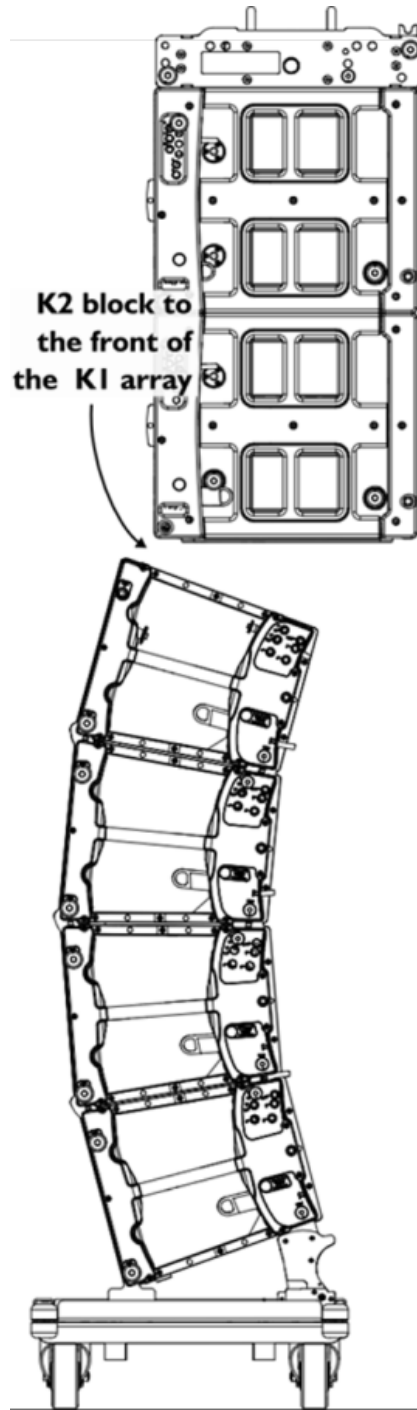

- a) Rotate the arm to align its hole with the K1/K1-SB rigging hole.

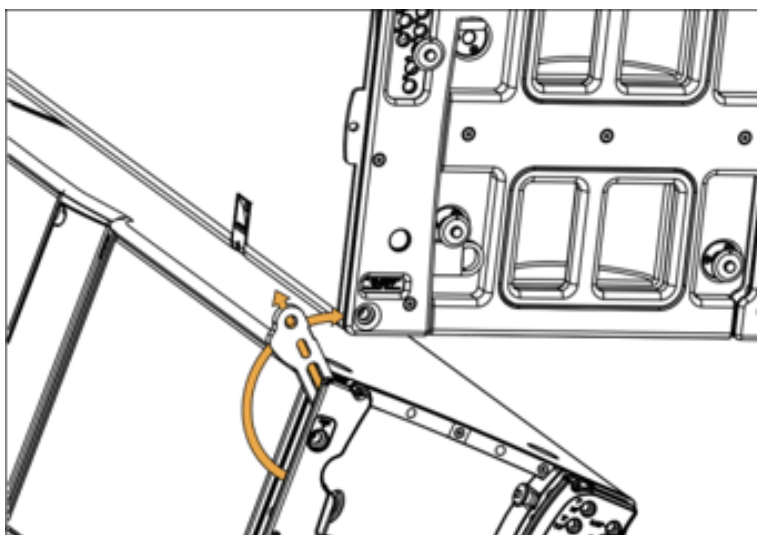

- b) Pin the arm on the flown array.

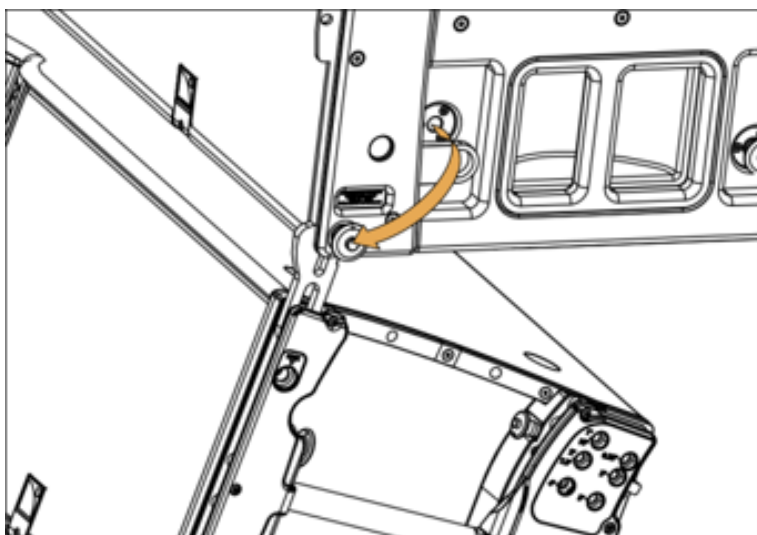

- c) Lower the flown array and secure the assembly with the LINK pin.



If you cannot insert the pin, move the flown array back and forth with enclosure handle.

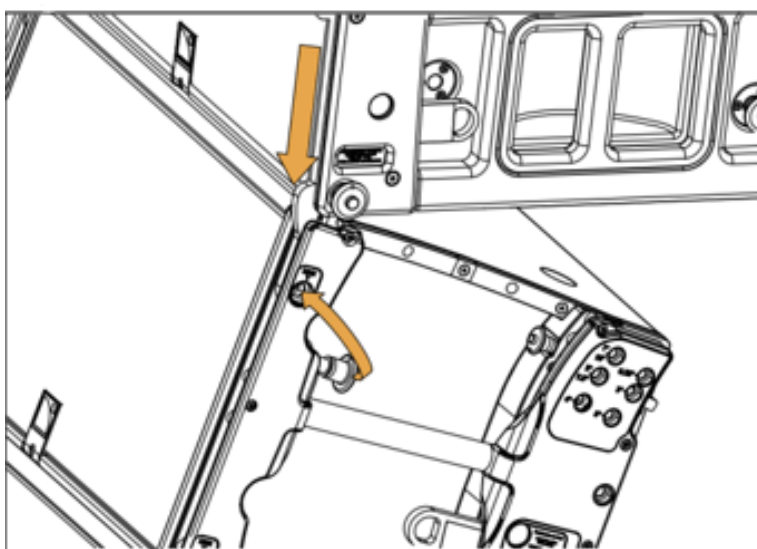

2. Raise the array to lock the inter-enclosure angles.

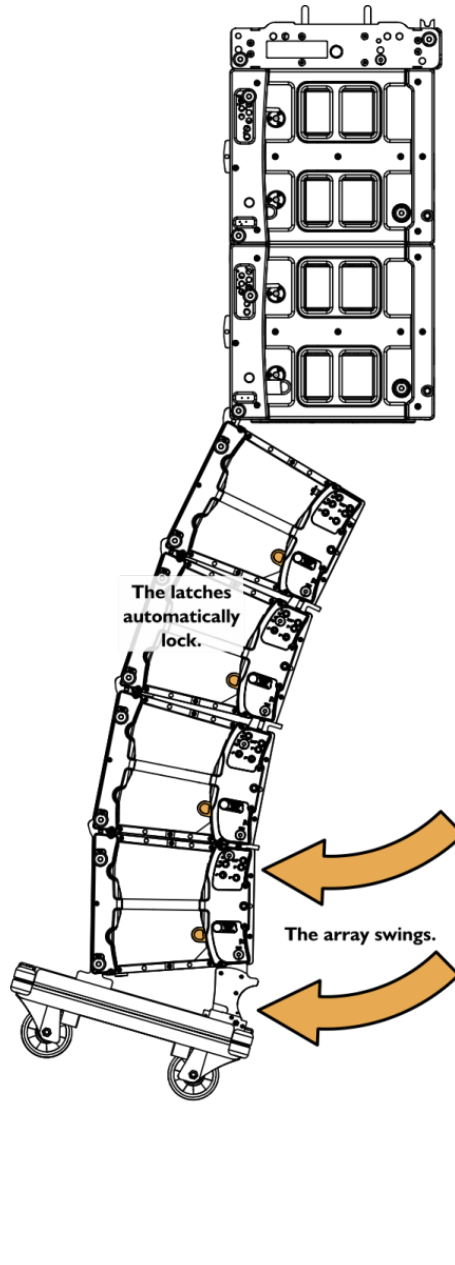
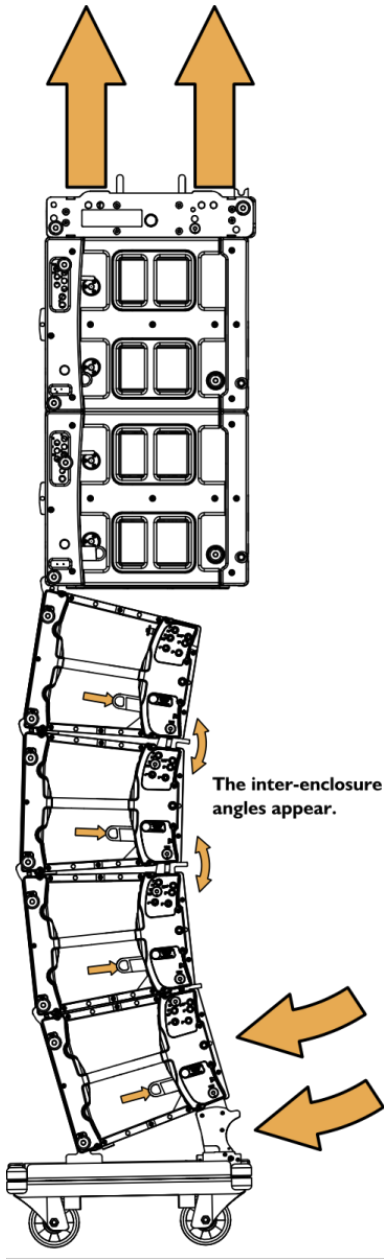

3. Turn the wheels inside the dolly.

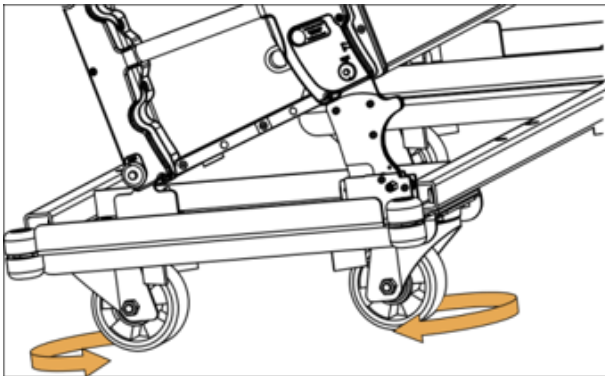

4. Connect the rear of the K1/K1-SB array to the rear of the K2 array with the K2-LINK interfaces:
 - a) On both sides, attach a K2-LINK at the back of the K1-SB enclosure.

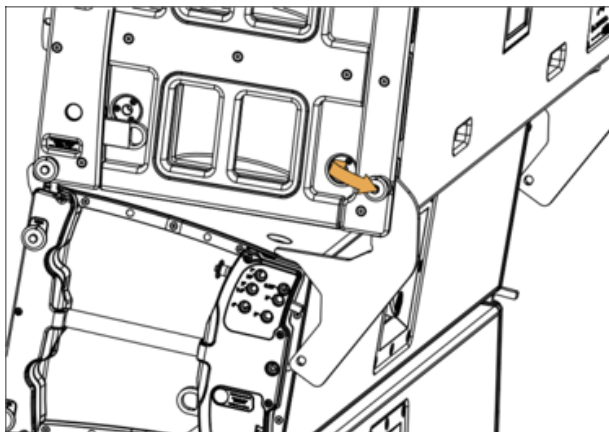

Do not pin K2-LINK on K2.

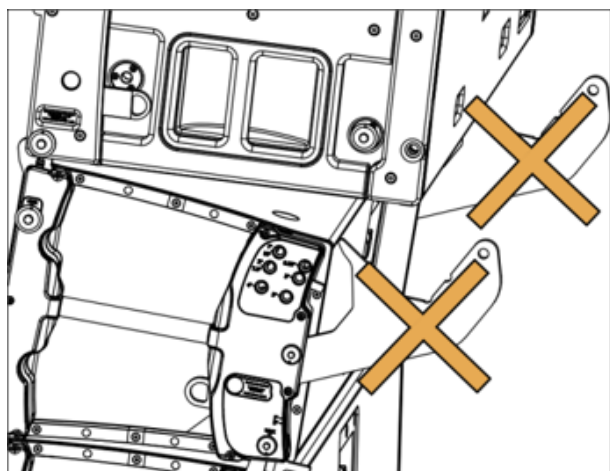

b) Pull back the bottom enclosures while lowering the array until only the front wheel touches the ground.

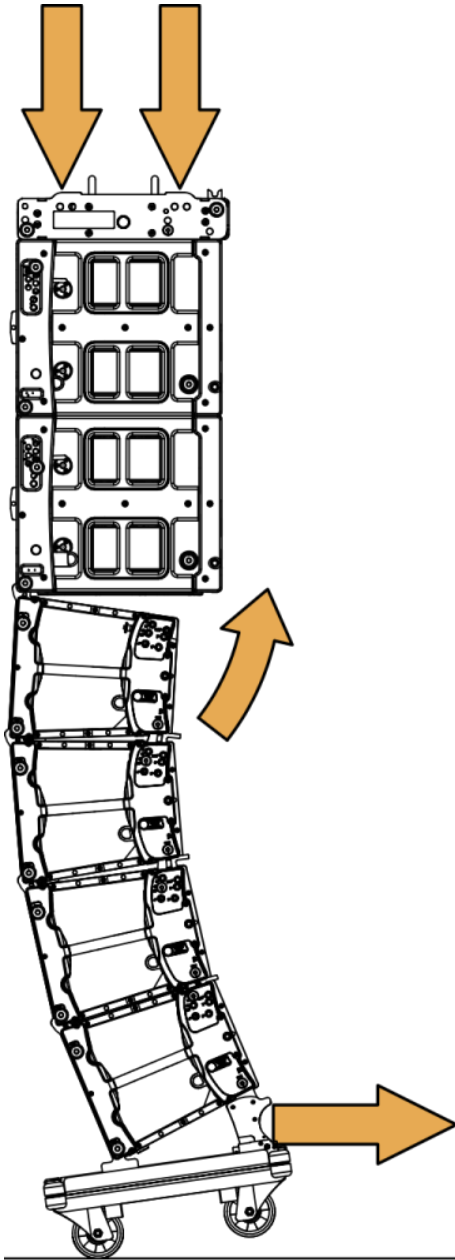

c) Push the K2-LINK into the K2 rear rigging.

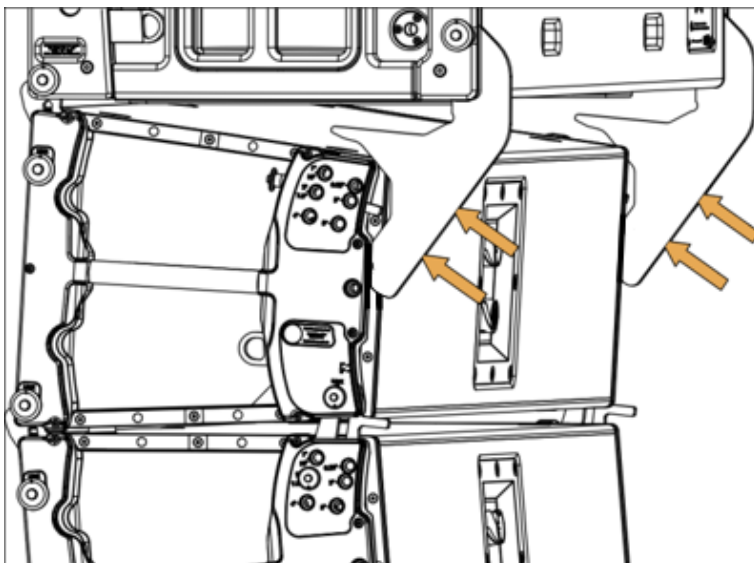

5. Lower the array until the hole of K2-LINK matches the K2 rigging middle hole.

**Risk of pinching**

Do not touch the K2-LINK while lowering the array.

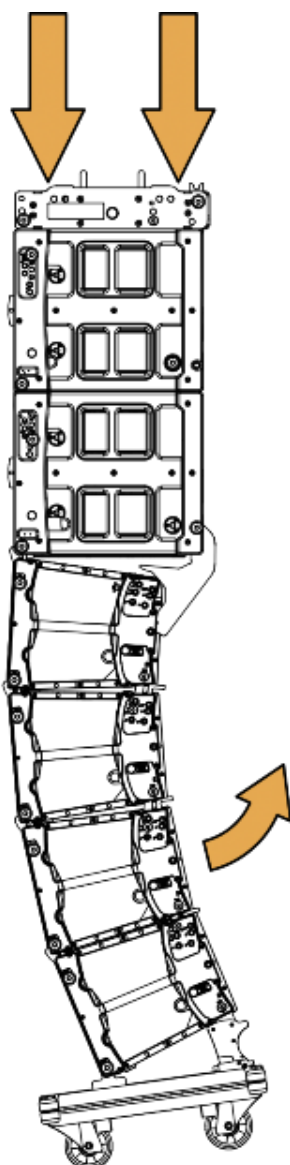

6. Secure the K2-LINK on the K2 rigging middle hole.

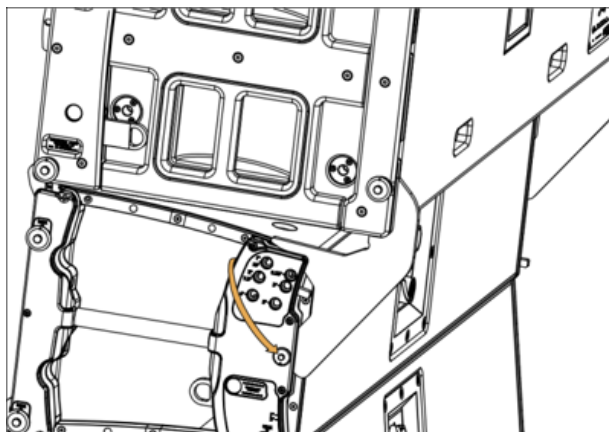

7. Remove the K2-CHARIOT:

a) Raise the array.

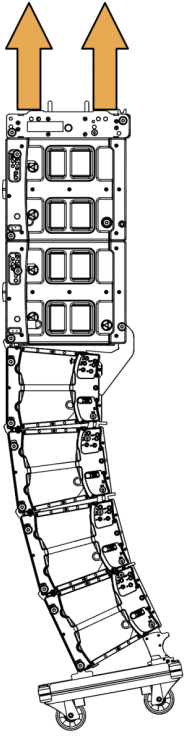

b) Hold the dolly with one hand. Remove the back pin on both sides.

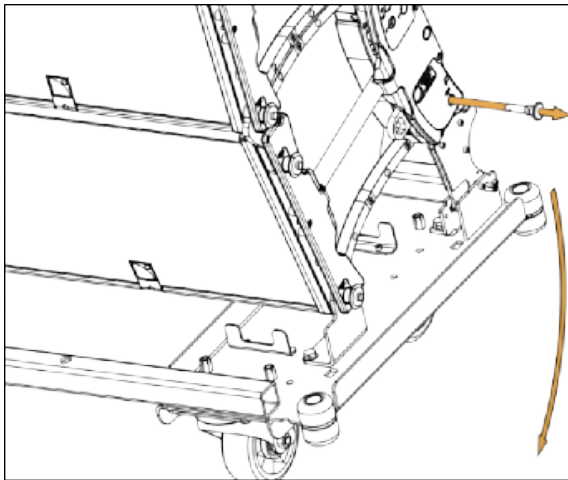

c) Hold the dolly with one hand. Remove the front pin on both sides.

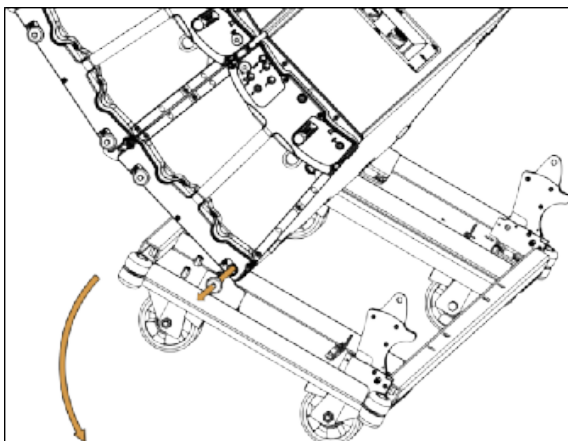

L - Attaching K1 or K1-SB under K2-BUMP

Procedure

1. Slide out K1-SB front rigging arm and pin it at 0° on both sides.

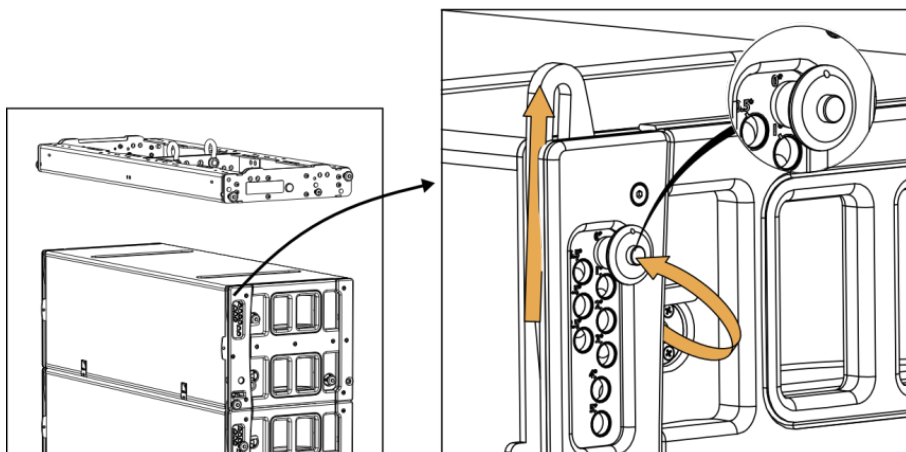

2. Attach the K2-BUMP to the K1 elements block:
 - a) Remove the K2-BUMP rear and front pins on both sides.
Lower the K2-BUMP so it rests on the topmost enclosure.

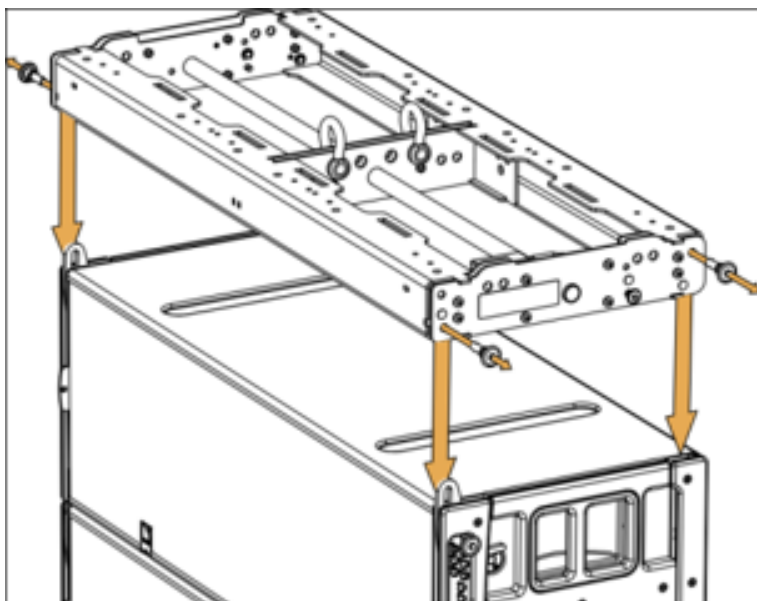

b) Rotate the rear rigging arm and pin it on the frame.

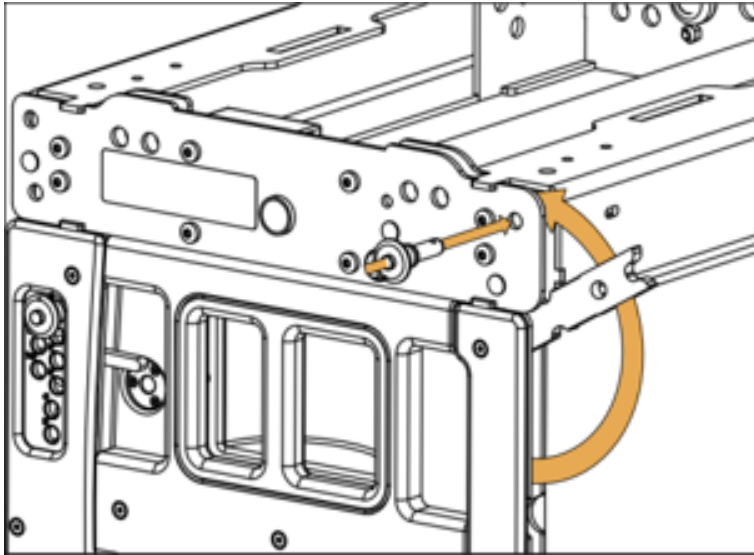

c) Pin the front rigging arm on the frame.

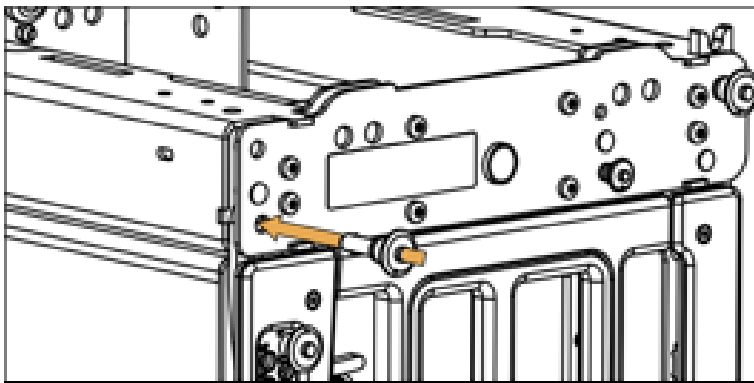

M - Mounting LA-RAK/LA-RAK II on K2-BUMP

rigging accessory

K2-BUMP / LA-RAK/LA-RAK II

K2-RAKMOUNT (2 rails for 1 LA-RAK/LA-RAK II)

tools

electric screwdriver with torque selector

6 mm hex bit

13 mm wrench

Procedure

1. Remove the nuts and bolts from the K2-RAKMOUNT rails.

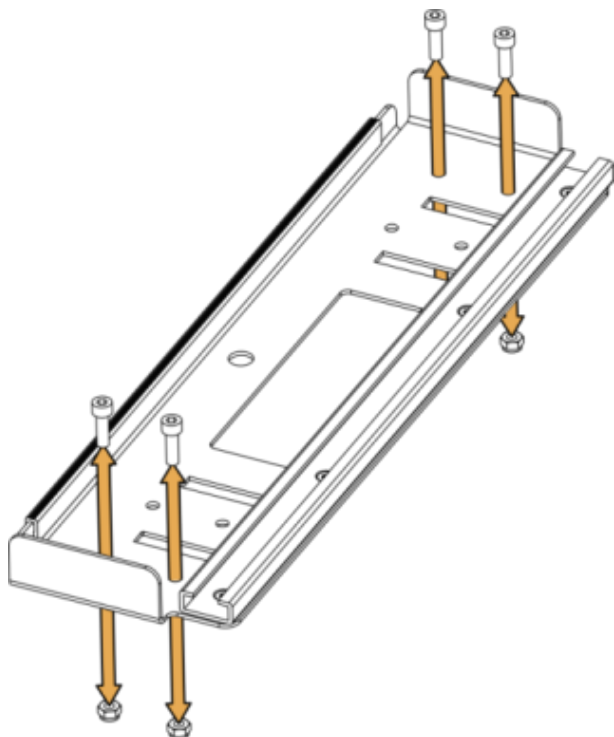

2. Position and secure as many rails as necessary on the K2-BUMP.

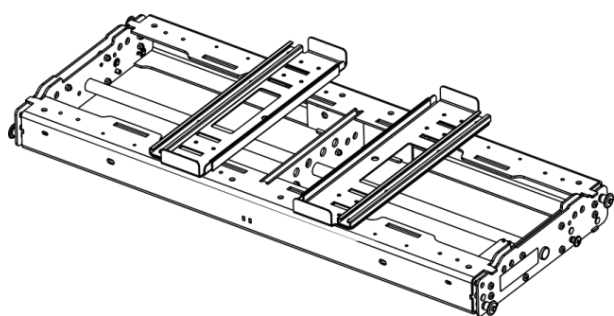

1 LA-RAK/LA-RAK II

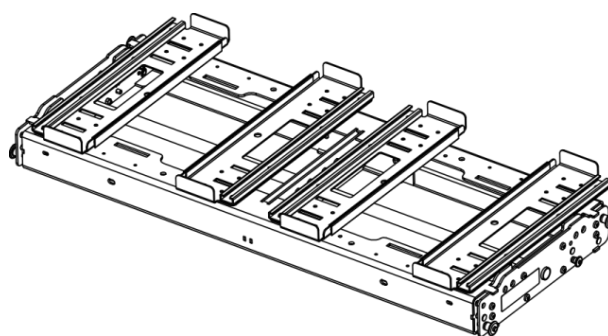

2 LA-RAK/LA-RAK II

3. Secure the rails on the K2-BUMP.

Set the torque to 5 N.m.



Before securing the side rails, make sure the frame pins are on the outside.

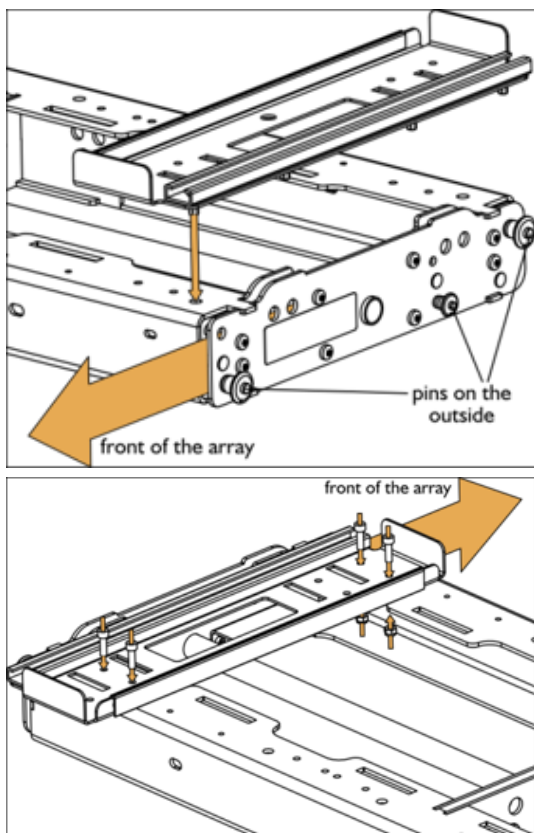

4. Install as many K2-BAR as necessary.



When installing a single K2-BAR at the center of the frame, make sure the pins are inserted between the central bar of the frame and the closest rail.

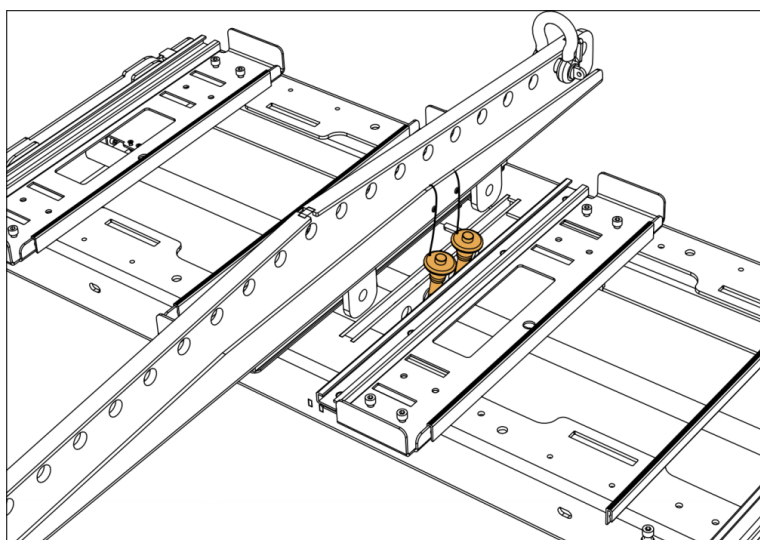

5. Remove the LA-RAK/LA-RAK II coupling bars:
- Turn the bars to release the spring-loaded safety and slide them out.

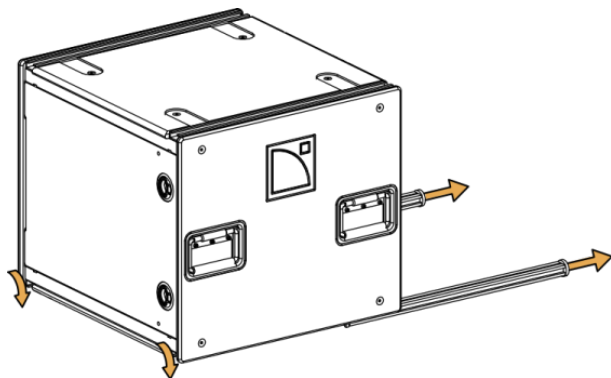

- Position the LA-RAK/LA-RAK II on the rails.

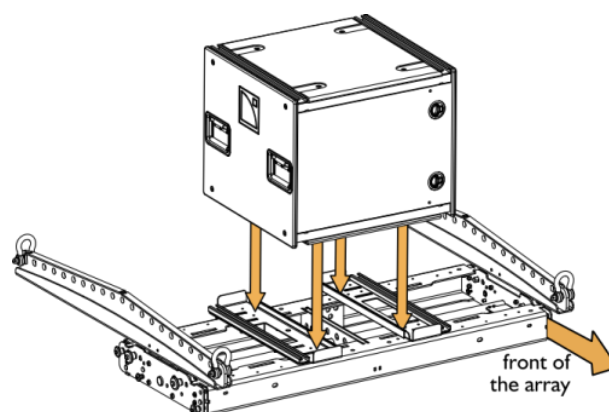
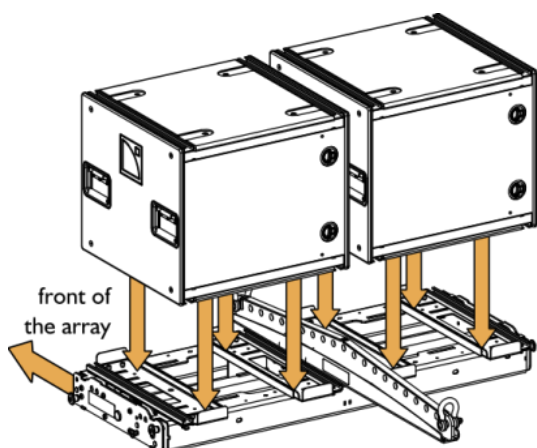

Coupling bars

Insert the coupling bars:

- from the back for a negative angle (rear extension)
- from the front for a positive angle (front extension)

Always insert so the metallic safety is pointed upward (depending on the tilt angle).

- Secure the LA-RAK/LA-RAK II with the coupling bars.

Insert the spring-loaded safety in the LA-RAK/LA-RAK II rails, give a quarter turn and slide the bar until the safety locks into place.

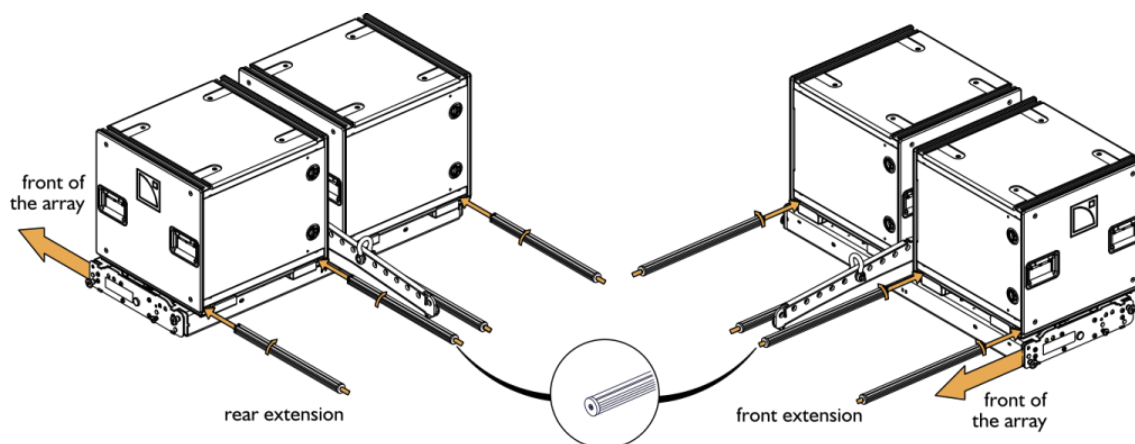

- 6.** If you are stacking 2 LA-RAK/LA-RAK II side-by-side on K2-BUMP, then insert the stabilizer between the two racks:
- a) Release the locking system by raising and turning the handle. Insert the stabilizer on the side opposite to the K2-BAR:
- From the front with a negative site angle (rear extension).

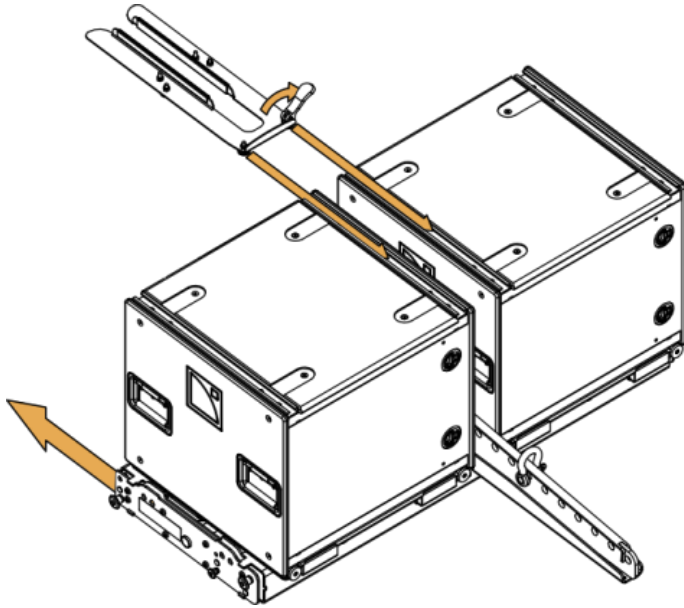

- From the rear with a positive site angle (front extension).

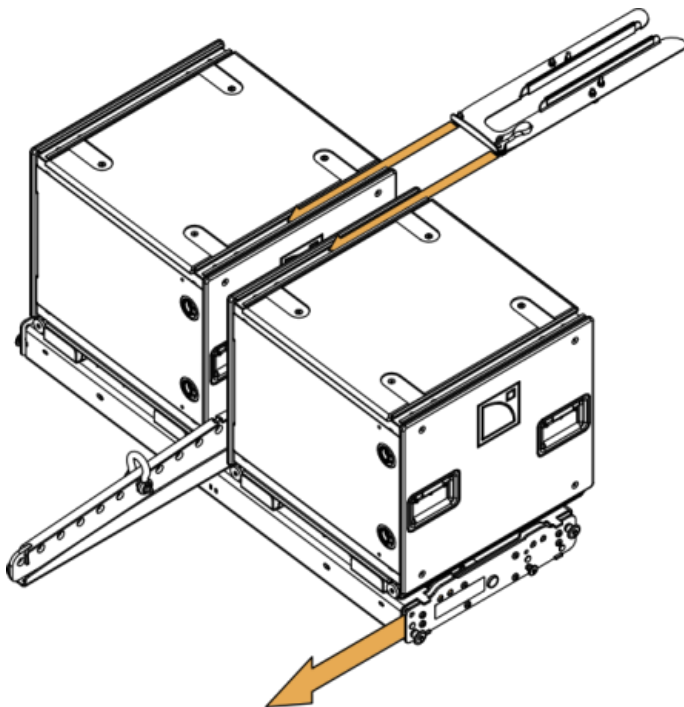

b) Secure the stabilizer by locking the handle.

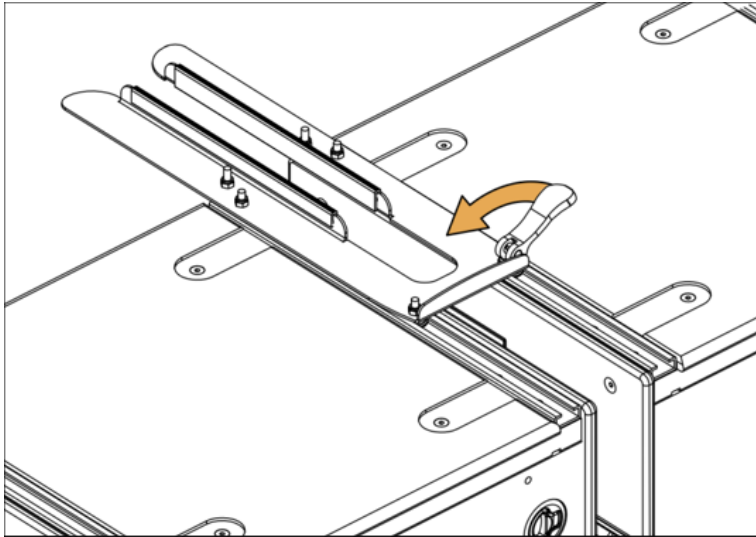

N - Using a K2-RIGBAR to implement a pullback

Space between linking points

The space between the two linking points used for this configuration must be aligned with the array pickup points. The deployment load-bearing lines must be parallel to each other.

under K2-RIGBAR

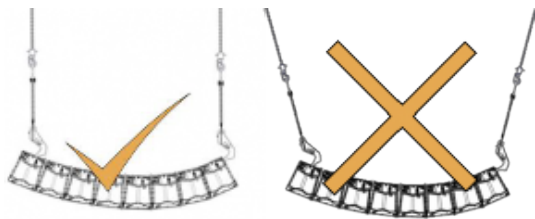

under K2-BAR



Procedure

1. Hang the LA-SLING2T to the hook.

 Make sure the chains are not twisted.

2. Attach the bar to the sling using the two 3.25 t WLL shackles. Use the interior holes of the bar.

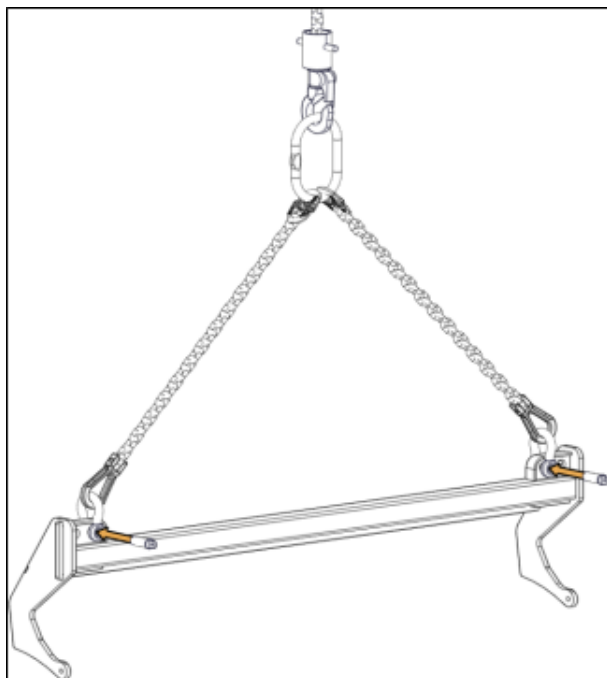

The external holes are dedicated to additional safety.

The additional safety must either be:

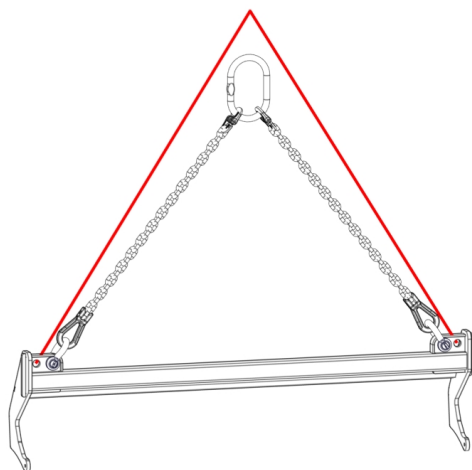

A two-leg bridle sling with a pickup point higher than the LA-SLING2T.

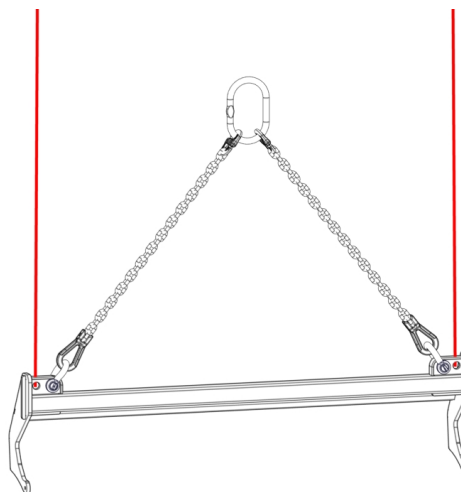

Two safety slings.



Do not use the rear rigging middle hole.

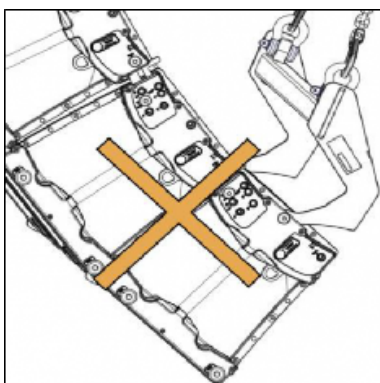

3. Attach the K2-RIGBAR to the bottom enclosure.



Use the rear rigging bottom hole.

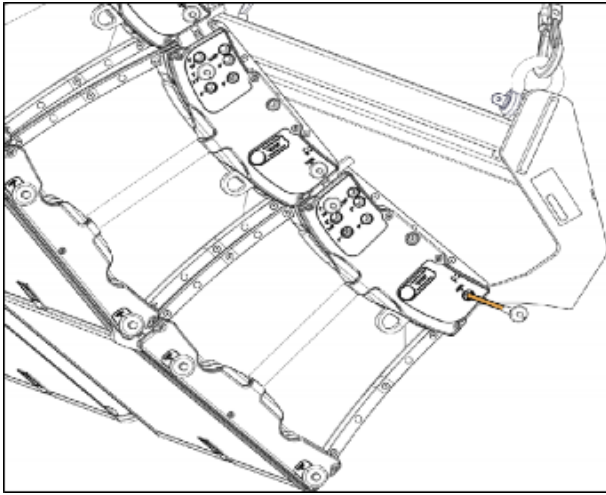

4. Adjust the height of the pickup-point.



Do not raise the rear pick-up point above the front pick-up point.
The chains must be as vertical as possible.



Under K2-RIGBAR



Under K2-BAR

O - Rigging a Kara II downfill array under a K2 array

Type of deployment	flown array
Rigging accessories	KARADOWNK2
Min number of operators	2

Assembly

About this task

! Reference rigging manuals

This procedure is complementary to the rigging instructions available in the main system rigging manuals. Refer to **the Kara II owner's manual** for more details.

Prerequisite

- Prepare and raise a K2 array. Refer to [A - Preparing a block of 4 K2](#) (p.69).
- Prepare an array of three Kara II with 0° inter-enclosure angles.
- Position the Kara II array under the K2 array.

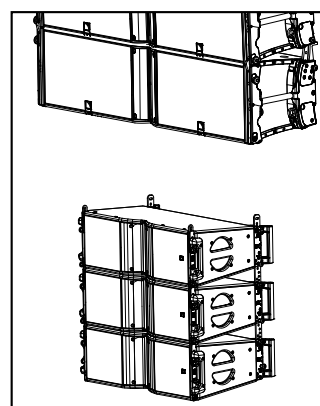

! Make sure the latches on the bottom K2 are in storage position.

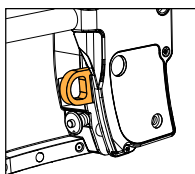

Procedure

1. Take out the four rigging arms on the top Kara II enclosure:
 - a) Lock the front rigging arms in linking position.

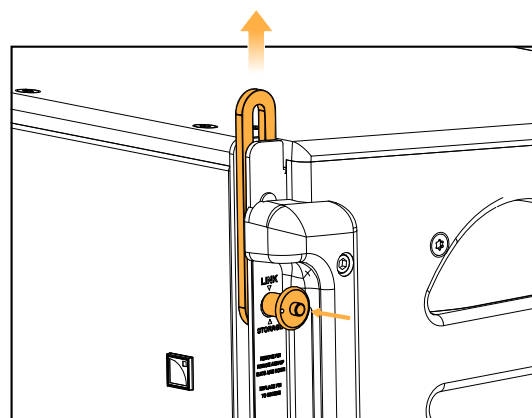
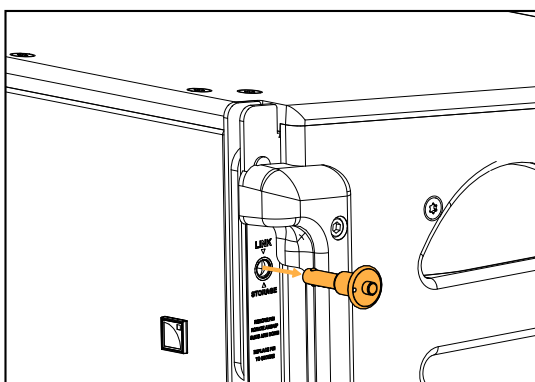

b) Slide up the rear rigging arms and select the same inter-element angle, from 0° to 10°.

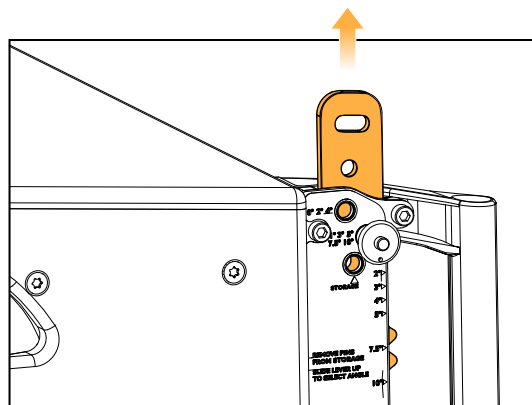
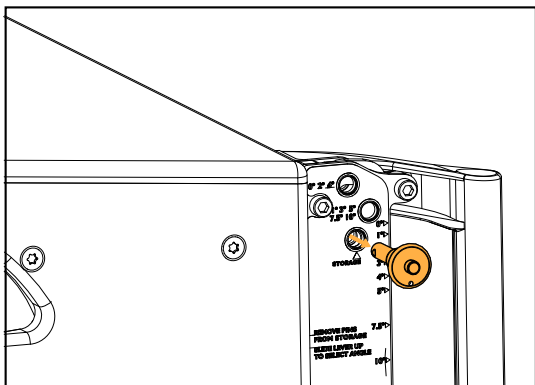

2. Secure a KARADOWNK2 on top of the Kara II array.



Position the higher ledge at the rear.

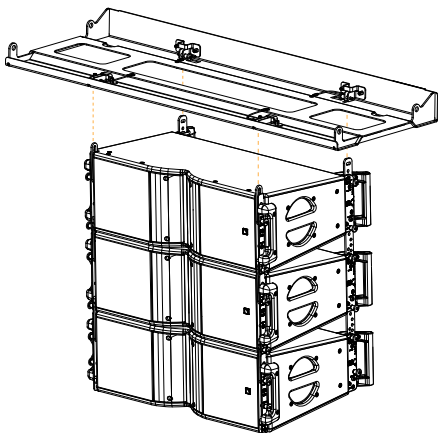

Secure the Kara II rigging arms inside the slits with the ball-locking pins.

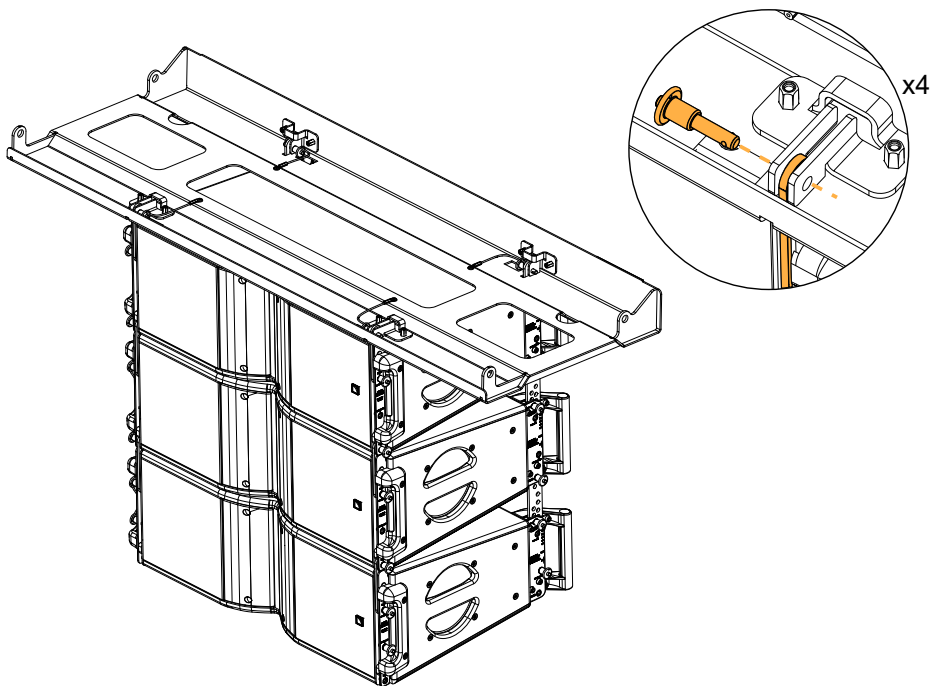

3. Lower the K2 array as close as possible to the assembly without resting on it.

4. Disconnect the rear rigging between the two top Kara II enclosures.

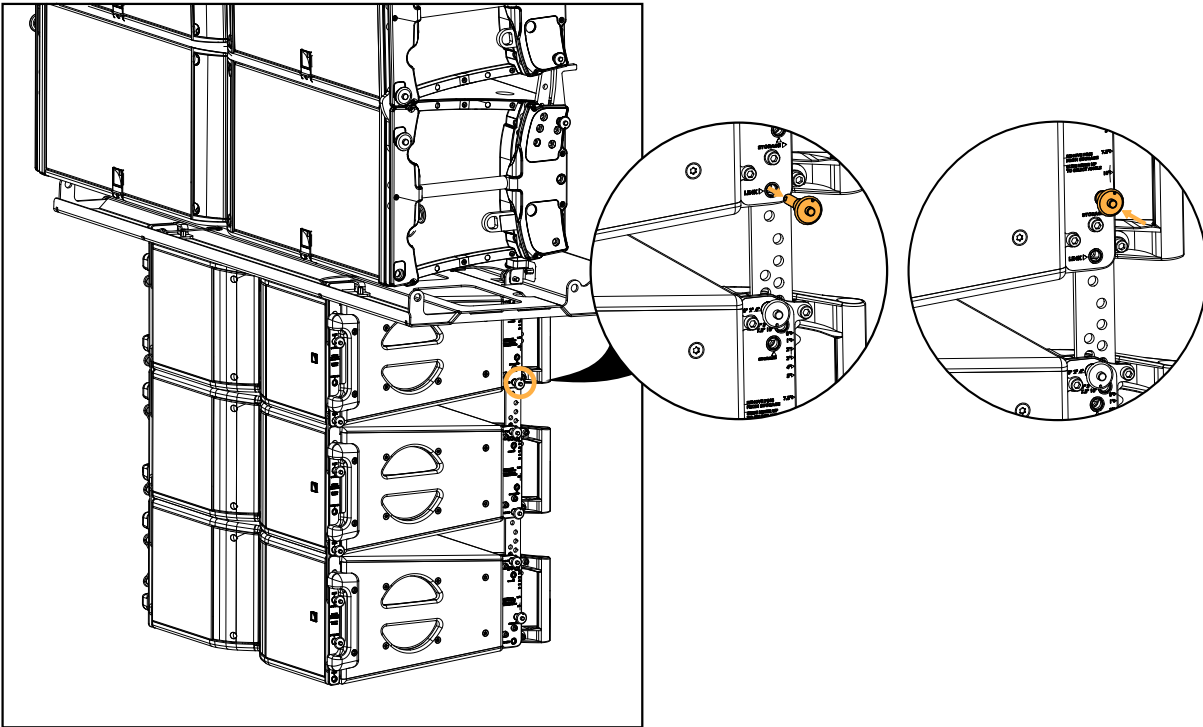

Risk of crushing injury.

Keep fingers away from the contact area between the ledge and the cabinet.



Risk of cable damage.

Disconnect any cable from the K2 bottom connector.

5. Connect KARADOWNK2 to the bottom of the K2 array:
 - a) Rotate the top Kara II upwards and secure the rear KARADOWNK2 tabs to the K2 rigging.

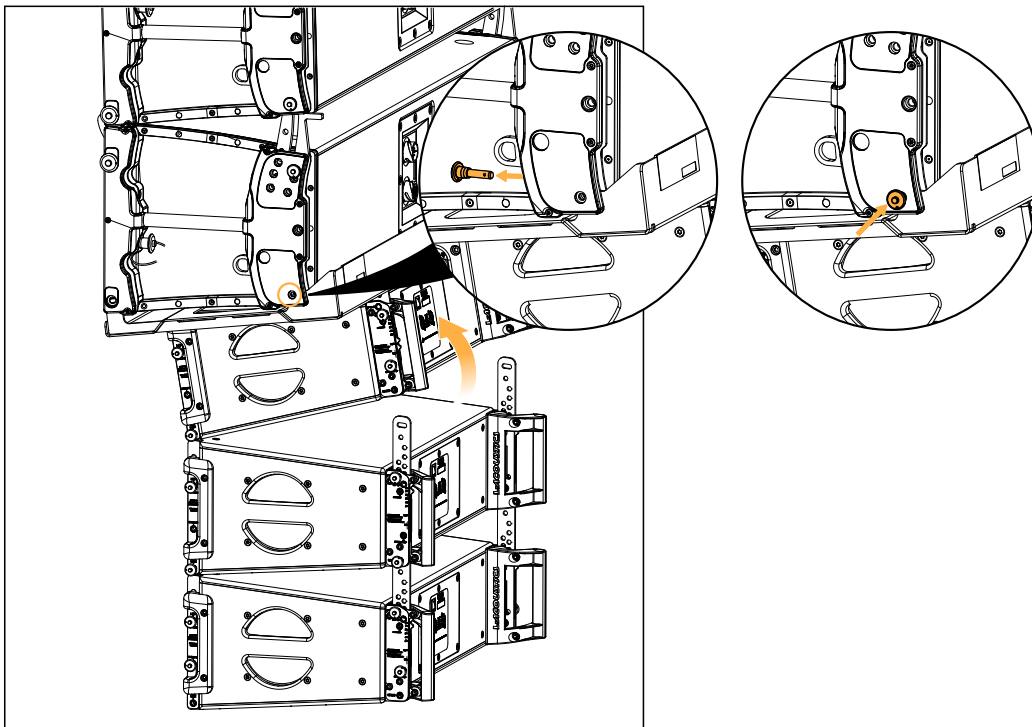

- b) Secure the front KARADOWNK2 tabs to the K2 rigging.
Slightly lower the K2 array if necessary.

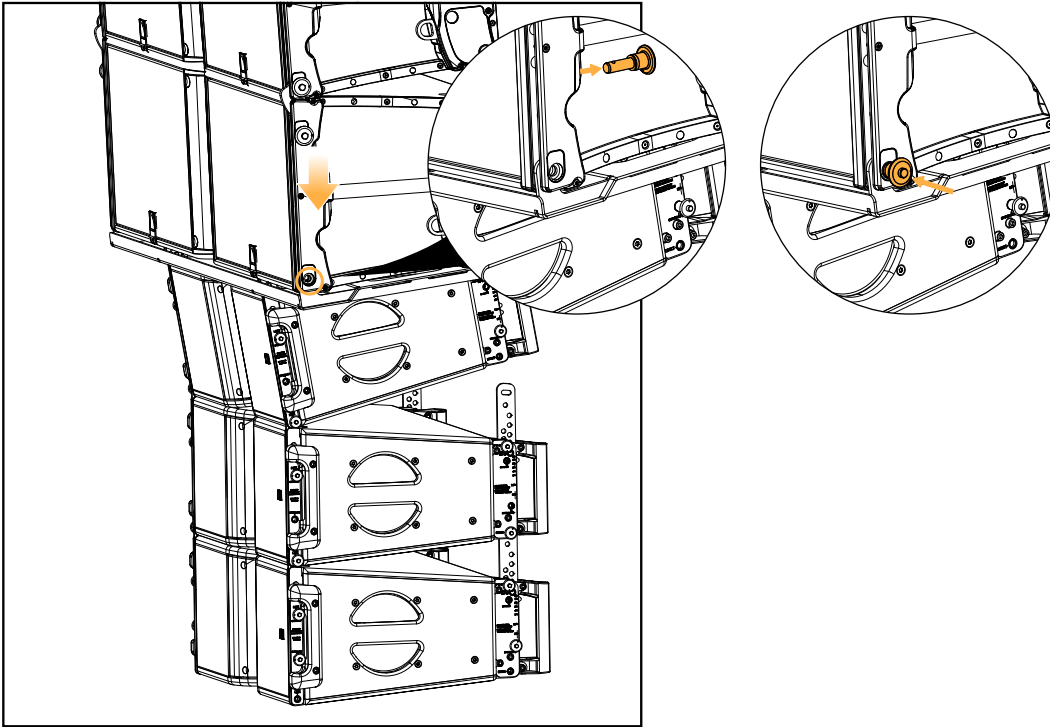

- c) Reconnect the top Kara II at the rear to the assembly.

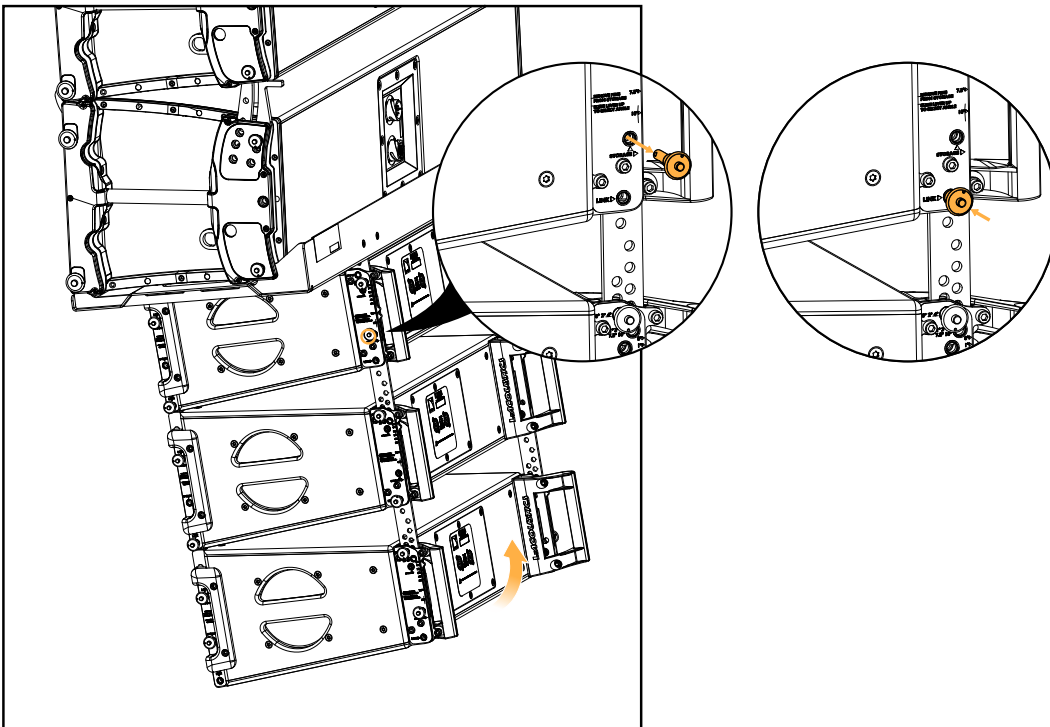

6. Raise the array.



Do not implement a pullback on a K2 array with a Kara II downfill.

7. Set the inter-enclosure angles.



Refer to the **Kara II owner's manual**.

Connection to LA amplified controllers

Enclosure drive capacity per amplified controller

Make sure the total number of connected enclosures does not exceed the maximum number of enclosures per controller (refer to the footnotes).

	LA4X	LA8	LA12X
	per output[*] / total	per output[*] / total	per output[*] / total
K2	1 / 1	3 / 3	3 / 3
Kara II	2 / 4	3 / 6	3 / 6
K1-SB	-	1 / 4	1 / 4
KS28	-	-	1 / 4
SB28	-	1 / 4	1 / 4

Cabling scheme for K2

Refer to the cabling schemes to connect the enclosures to different types of output connectors.

i L-Acoustics does not supply the speakON-to-PA-COM interface. It must be built with two 4-point speakON connectors and a female 8-point PA-COM connector (no cable clamp).

Four-channel CA-COM output

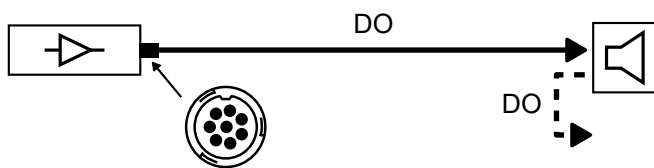

2 x Two-channel speakON output

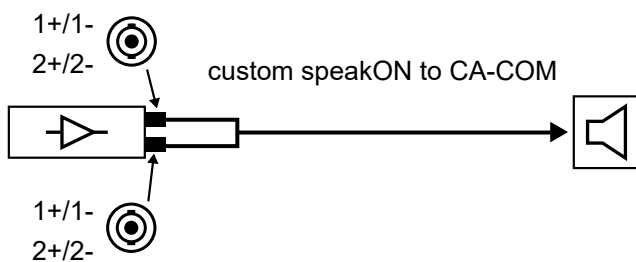

* For passive loudspeakers, the value corresponds to the number of enclosures in parallel on the output. For active loudspeakers, the value corresponds to the number of sections in parallel on the output.

Cabling scheme for Kara II

Four-channel CA-COM output

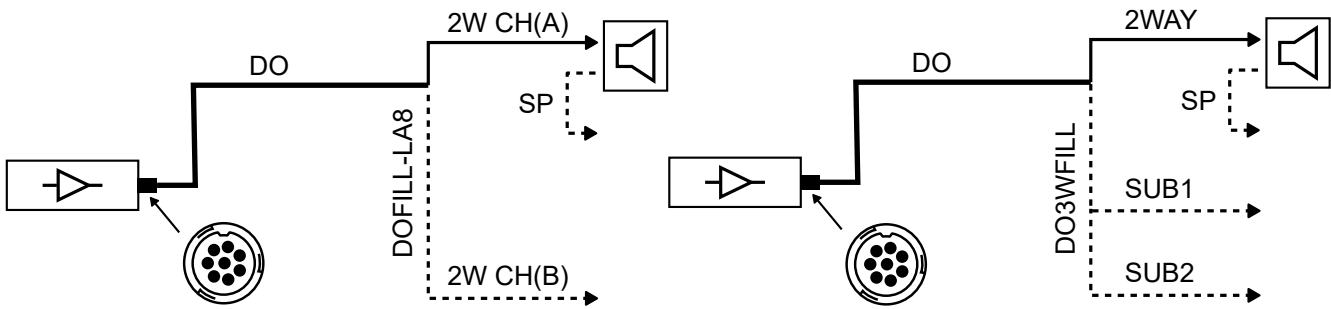

Two-channel speakON output

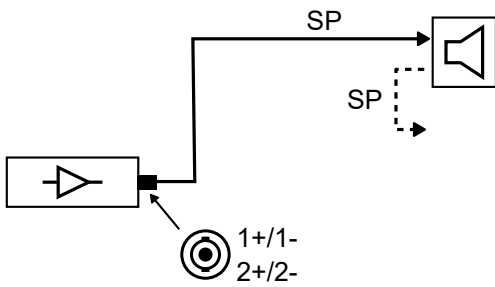

Cabling schemes for subwoofers

Two-channel speakON output

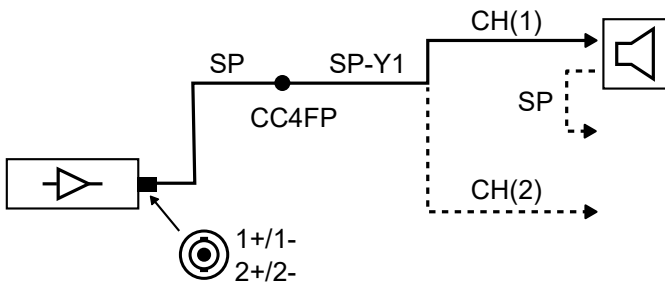

Four-channel CA-COM output

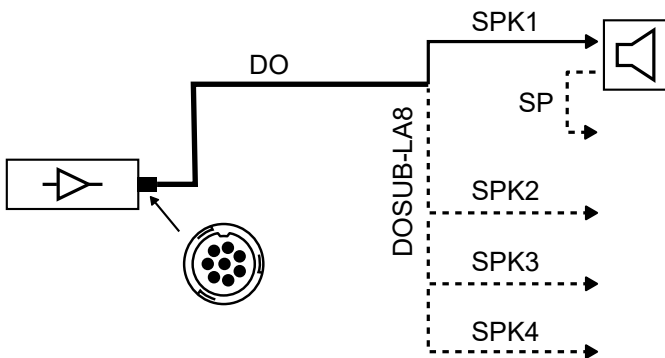

Corrective maintenance



Kara II and KS28

Refer to the **Kara II owner's manual** and the **KS28 user manual** for more information on the corrective maintenance.

K2

Disassembly and Reassembly procedures

In order to operate, follow the order outlined here.

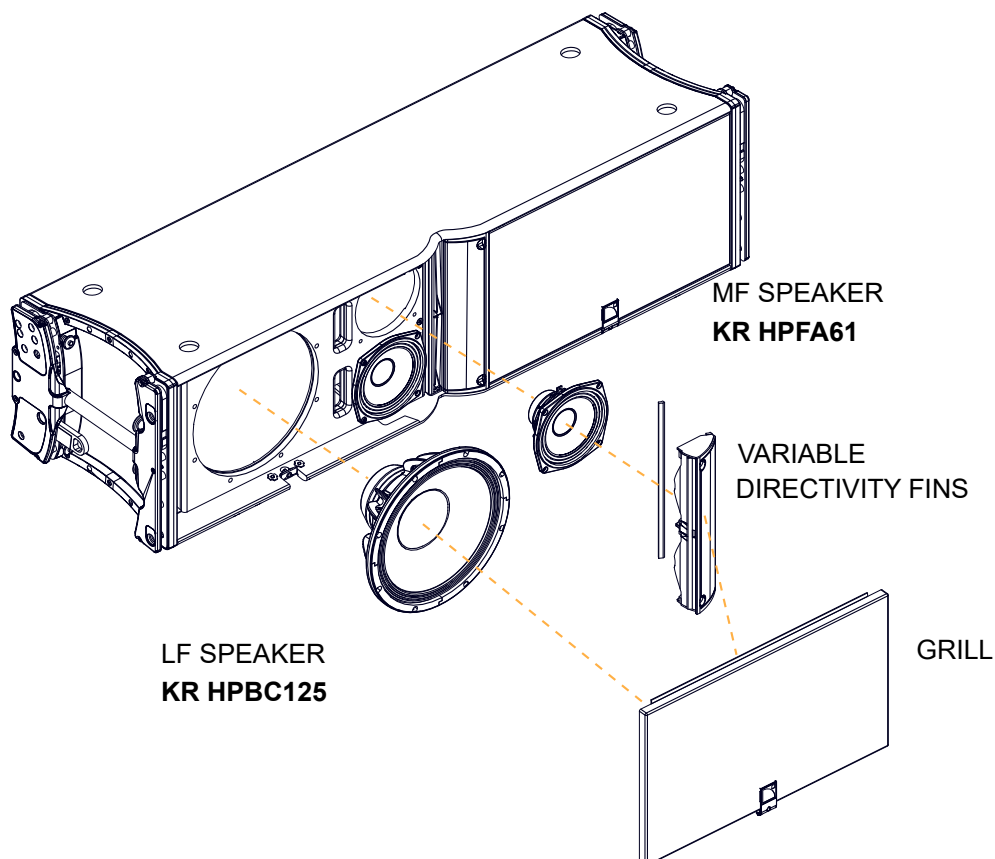

D/R - CONNECTOR PLATE

Tools

- torque screwdriver
- T15 Torx bit

Consumables

- blue threadlocker

Repair kit

KR HPBC34

Kit HP BC34 Driver 3 - 8 ohms

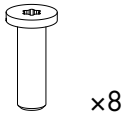

S100035

M5x16 Torx

Disassembly

Procedure

1. Remove the eight screws securing the connector plate.

! Save the screws for reassembly.

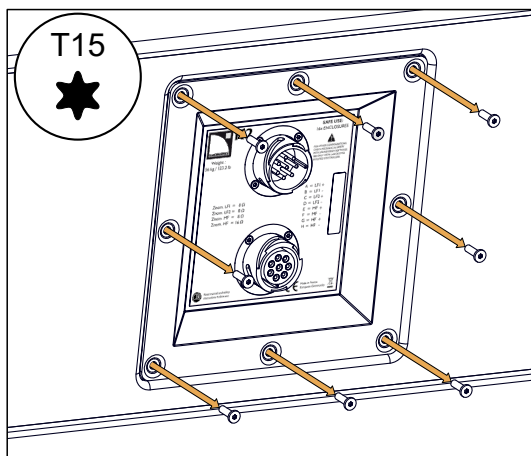

2. Remove the connector plate using a lever.

Avoid straining the speaker cables.

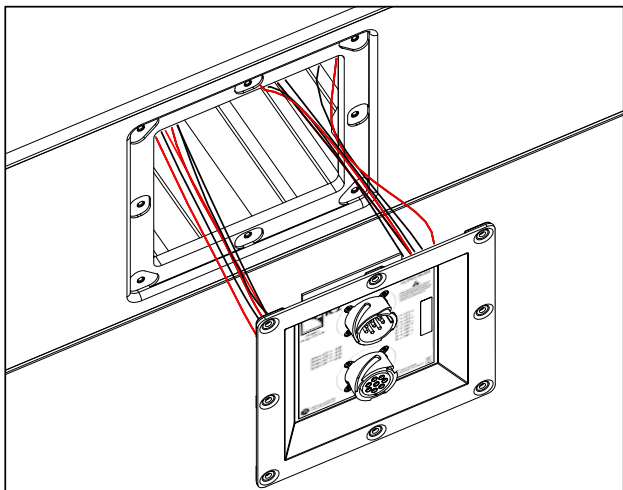

3. Disconnect the cables.

Reassembly

About this task

- ❗ For safety reasons, always use the new screws and spare parts provided in the KR.
If no new screws are available, use blue threadlocker.

Procedure

1. Connect the cables.
2. Position the connector plate using the label as a reference.
 - ❗ Gradually tighten the screws following a star pattern.
 - i** Put blue threadlocker on the screws.
3. Secure the connector plate.

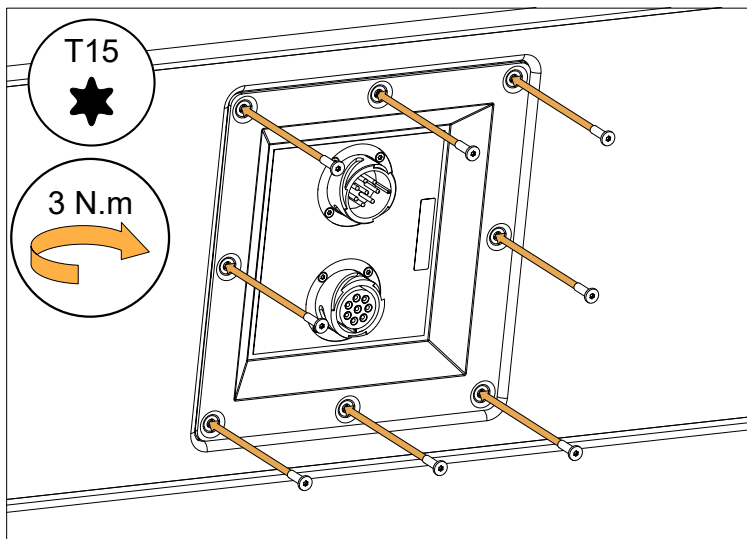

D/R - GRILL**Tools**

- torque screwdriver
- 4 mm hex bit
- 100226 (provided)

Repair kit**KR SECUGRL**

Kit 100 safety O-rings for front grill

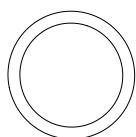

x100

100557

grill safety O-ring

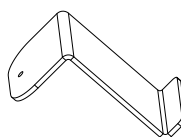

x1

100226

grill safety tool

Prerequisite

The enclosure is placed on its bottom face.

Disassembly**Procedure**

If the grill is secured with an O-ring, pull it down before removing the grill.

1. Loosen the captive screw of the grill mounting bracket.



4 mm

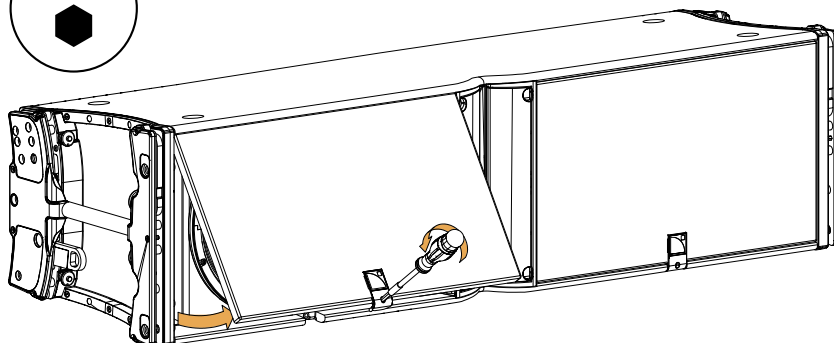

2. Slide down the grill and remove it.

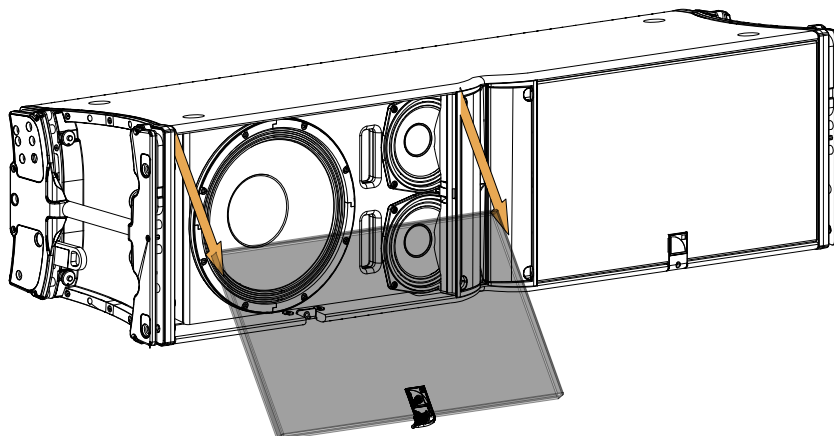

Reassembly

Procedure

1. Slide the O-ring under the captive screw insert.

Use a flat-head screwdriver to push the O-ring under the insert.



2. Apply blue threadlocker on the grill screw.
3. Insert the top of the grill.

Stretch the O-ring with the tool provided in the KR.

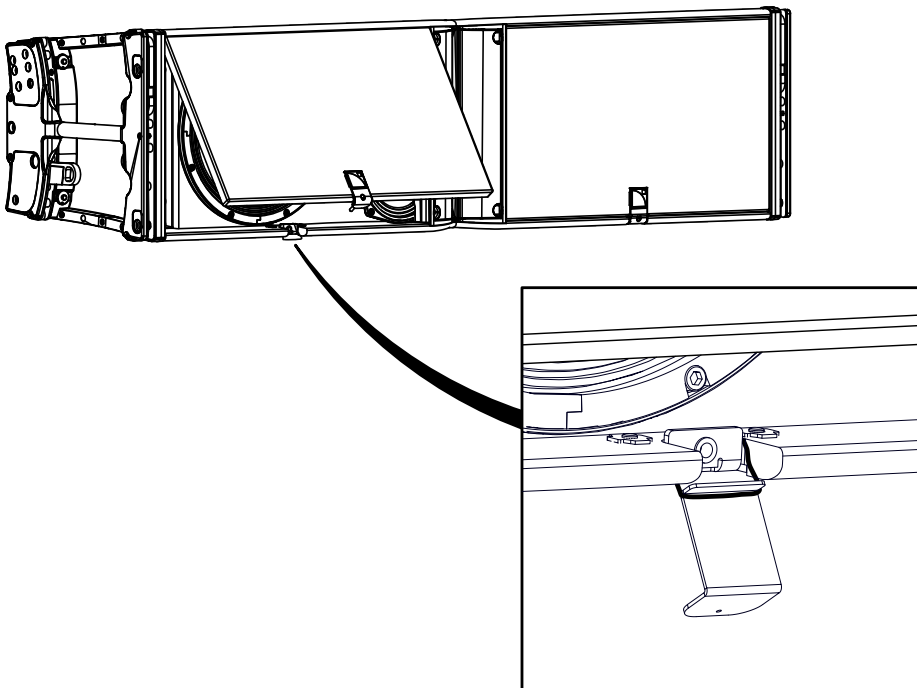

4. Close the grill.

Pull the O-ring so it goes around the grill logo and above the captive screw.

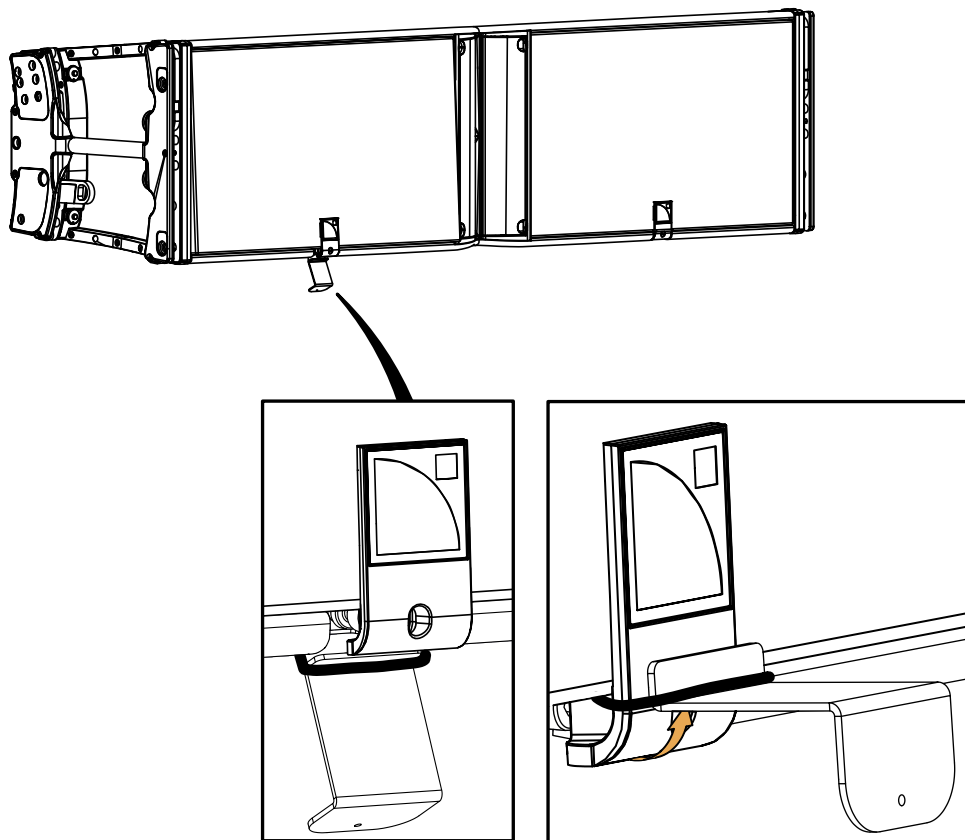
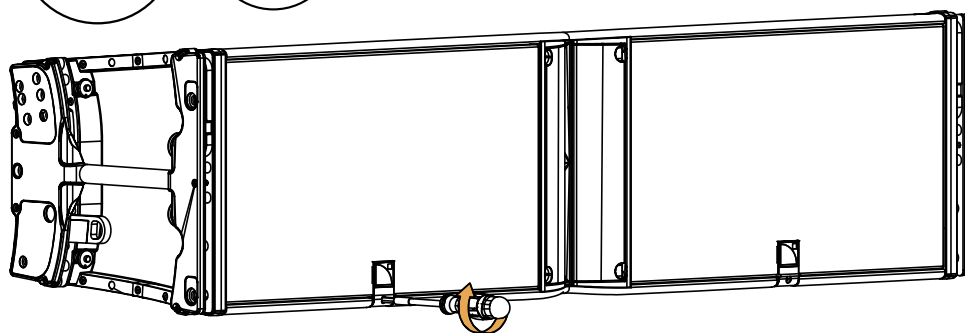
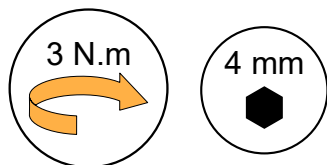
**5.** Secure the grill with the captive screw.

D/R - VARIABLE DIRECTIVITY FINS

Tools

- torque screwdriver
- 4 mm hex bit
- flat tool

Repair kit

KR HPFA61

Kit HP FA61 Driver 6.5" - 8 ohms

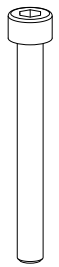

x4

S100108

M5x45 hex



x4

S321

washer with gasket



x1

1396

dust cover gasket

Prerequisite

Grill removed.

See [GRILL](#) (p.133).

Disassembly

Procedure

1. Unhook the fin with a flat tool.

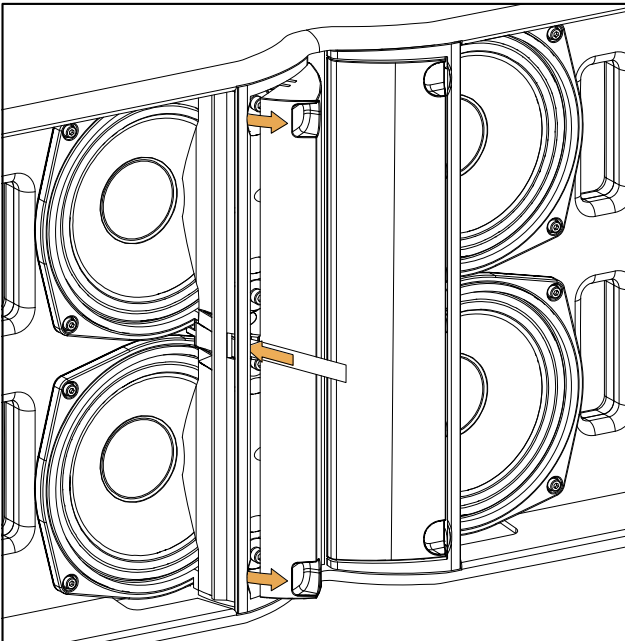

2. Remove the four screws.

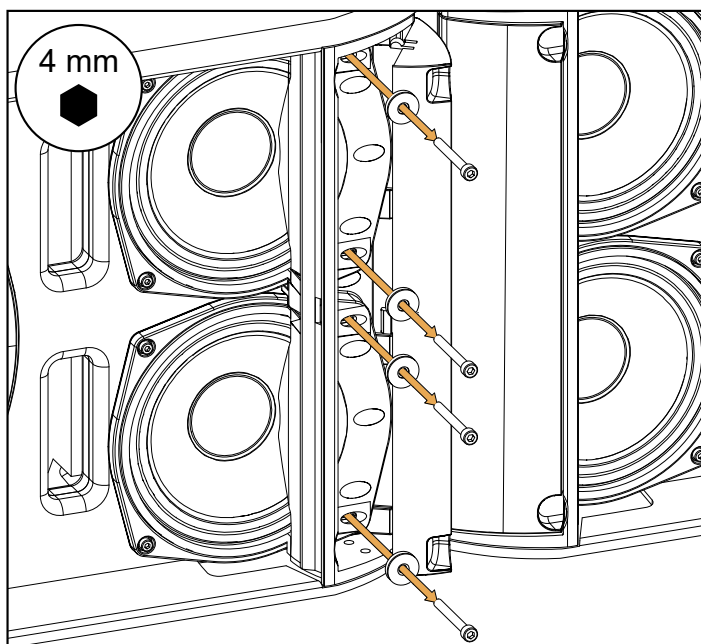

At this point, the medium driver can be accessed without further disassembly of the fin.

Reassembly

About this task



For safety reasons, always use the new screws and spare parts provided in the KR. If no new screws are available, use blue threadlocker.

Procedure

1. Secure the fin with the provided screws and washers.

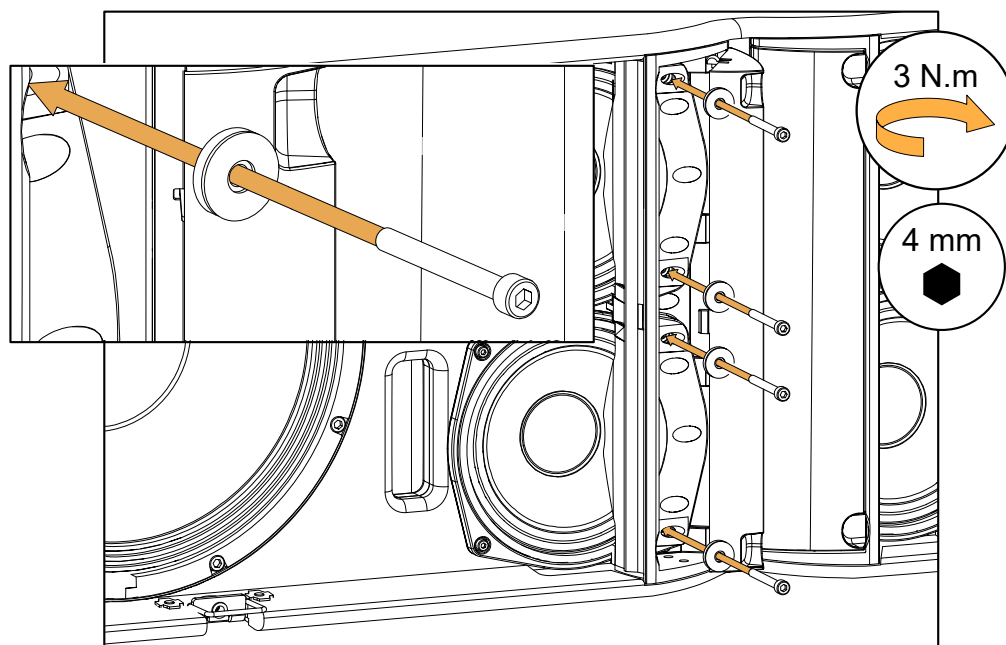

2. Clip the moving part in the frame.

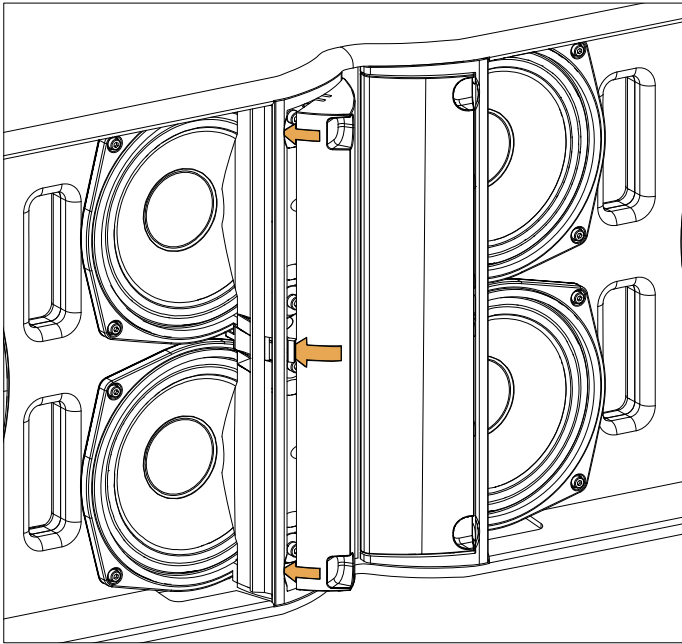

3. Verify the fin mobility.

D/R - LF SPEAKER**Tools**

- torque screwdriver
- 5 mm hex bit

Repair kit**KR HPBC125**

Kit 12" speaker - 8 ohms

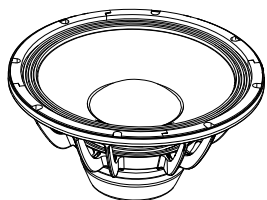

x1

1277

12" LF speaker



x8

S100036

M6x25 hex

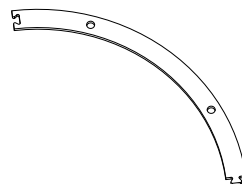

x4

1250

12" speaker gasket

Prerequisite

Grill removed.

See [GRILL](#) (p.133).**Exploded view**

For safety reasons, always use the new screws and spare parts provided in the KR.

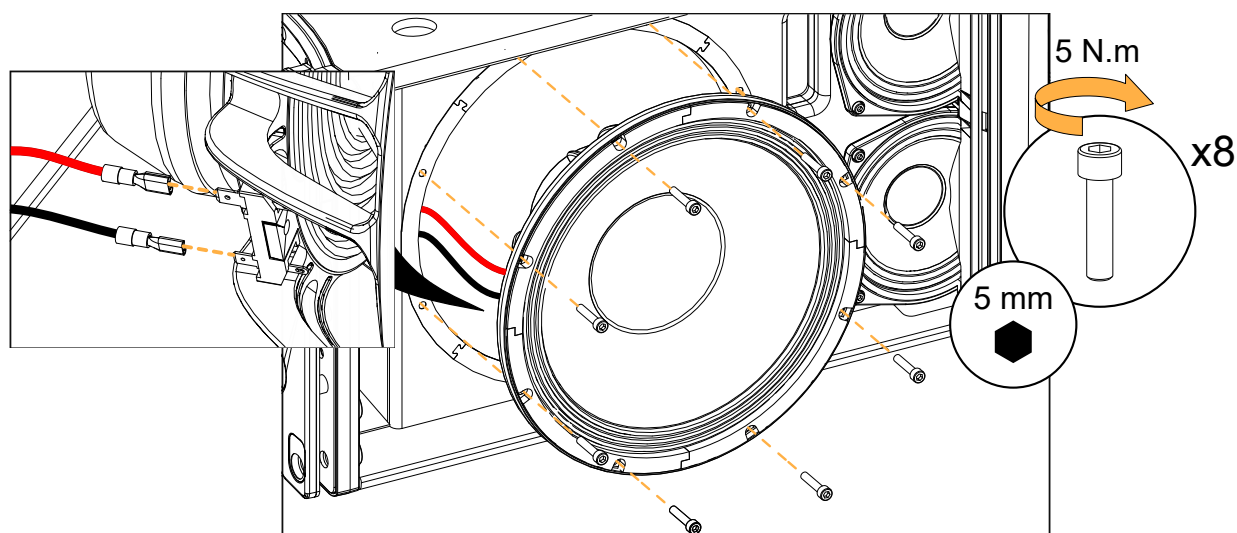

If the speaker gasket is damaged, remove and replace it.

**What to do next**Perform the [Acoustical check](#) (p.57) procedures.

D/R - MF SPEAKER

Tools

- torque screwdriver
- 4 mm hex bit

Repair kit

KR HPFA61

Kit HP FA61 Driver 6.5" - 8 ohms

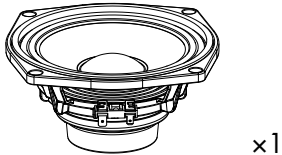

1278

6.5" MF speaker

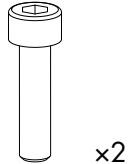

S342

M5x20 hex

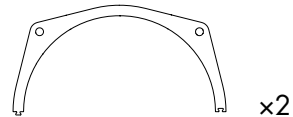

1513

6.5" speaker gasket

Prerequisite

Grill removed.

Fins disassembled.

See [GRILL](#) (p.133).

See [VARIABLE DIRECTIVITY FINS](#) (p.136).

Exploded view



For safety reasons, always use the new screws and spare parts provided in the KR.



Gradually tighten the screws following a star pattern.



If the speaker gasket is damaged, remove and replace it.

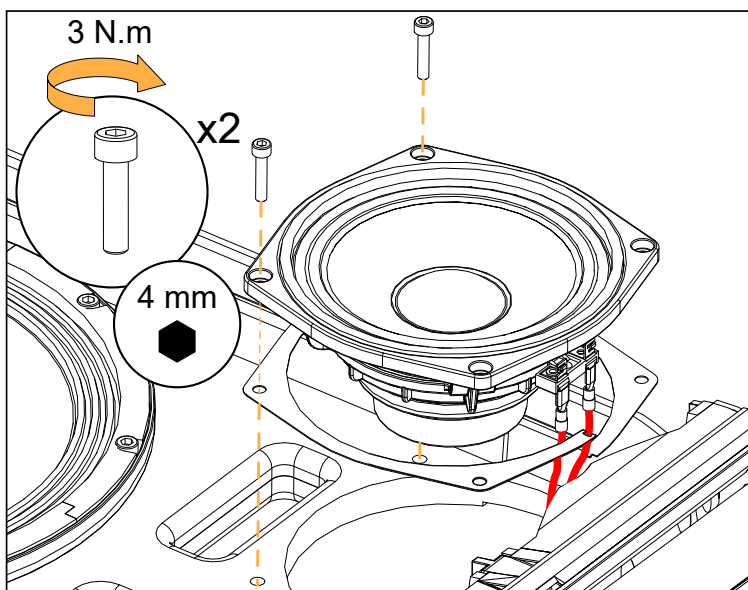

Position the connectors toward the fins.

What to do next

Perform the [Acoustical check](#) (p.57) procedures.

D/R - HF DRIVER**Tools**

- torque screwdriver
- 5 mm hex bit

Repair kit**KR HPBC34**

Kit HP BC34 Driver 3 - 8 ohms

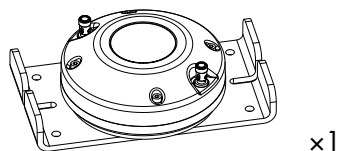

G199

3" HF driver - 8 ohms assembly

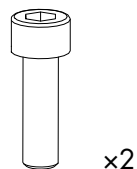

S100105

M6x20 hex

Prerequisite

Connector plate removed.

See [CONNECTOR PLATE](#) (p.130).

Disassembly**Procedure**

1. Remove the HF driver cables.
Free the cables by pressing the driver push-buttons.
2. Remove the two screws securing the assembly.

! Save the screws for reassembly.

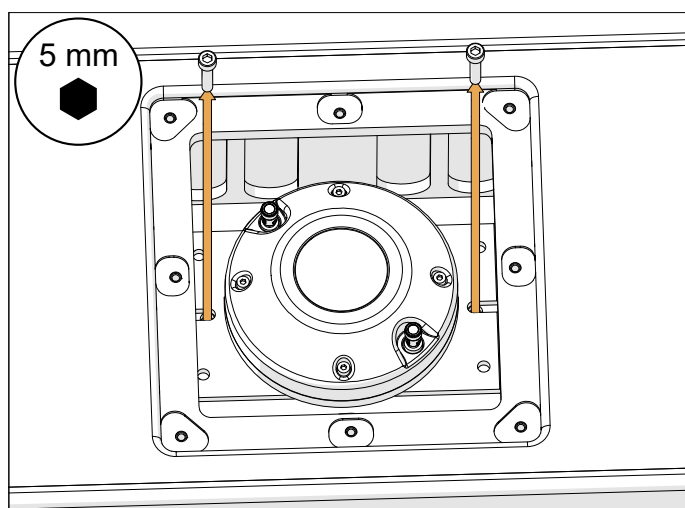

3. Remove the HF driver assembly.

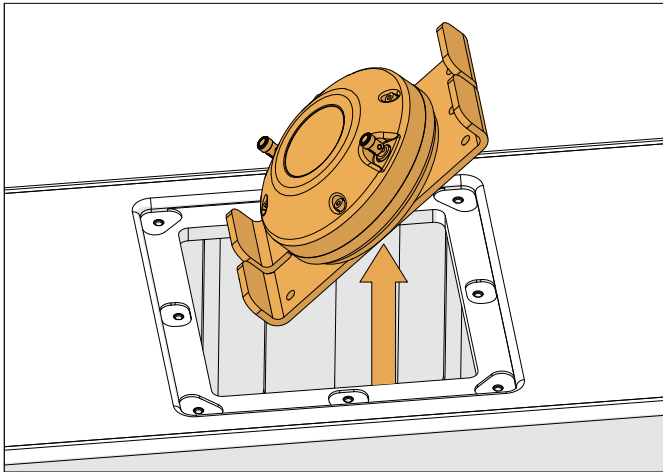

Reassembly

About this task

! For safety reasons, always use the new screws and spare parts provided in the KR.

Procedure

1. Position the HF driver assembly in the cabinet.

Align the plate with the cabinet inserts and position the red connector on the left.

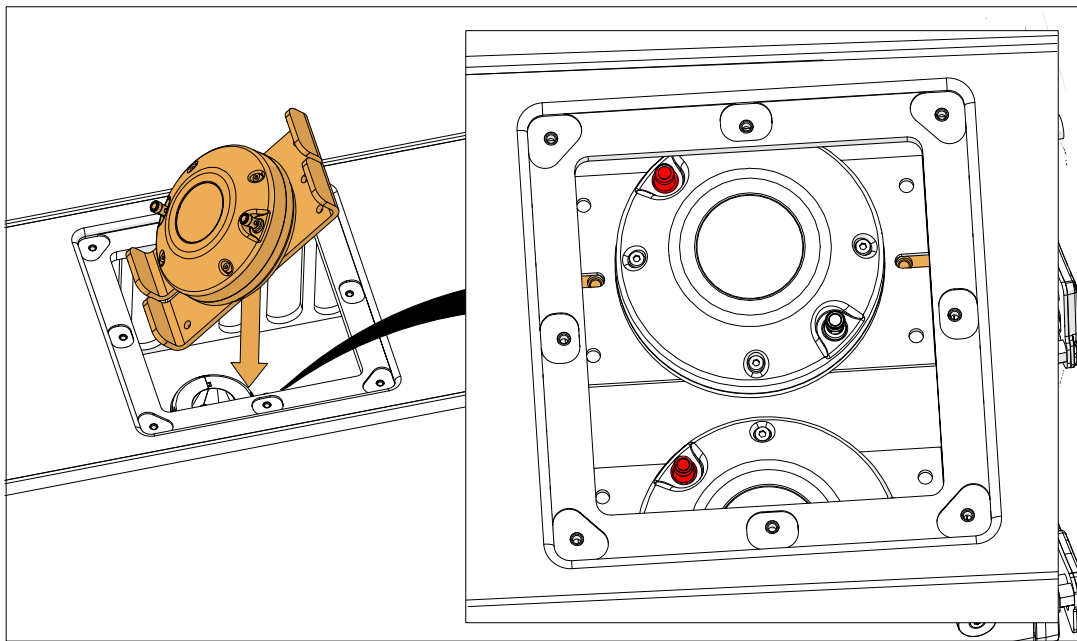

2. Secure the assembly.

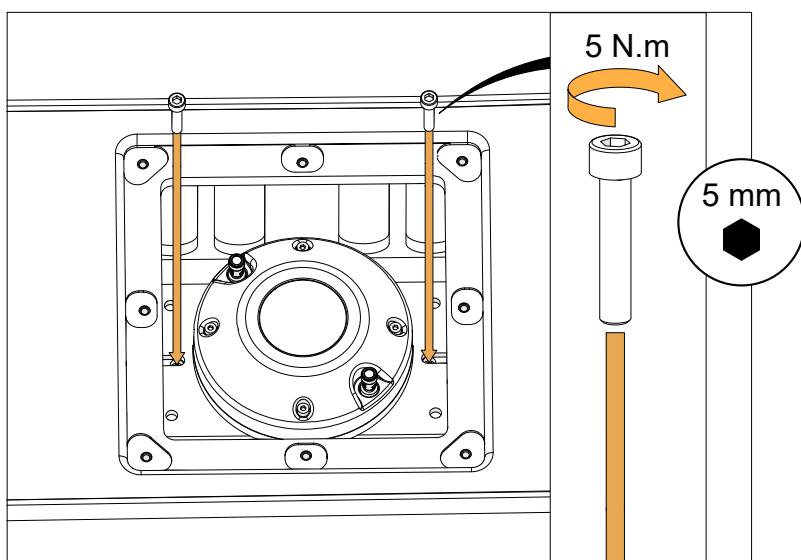

3. Connect the corresponding speaker cables to the high-frequency driver.

D/R - HF DRIVER DIAPHRAGM

Tools

- torque screwdriver
- 3 mm hex bit
- 3 mm hex wrench

Consumables

- double face adhesive tape

Repair kit

KR HSBC34

KitDiaphragm for HP BC34II (3" driver - 8 ohms)

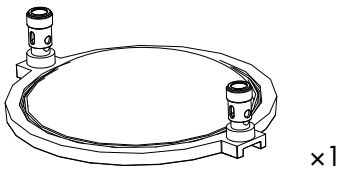

1438
diaphragm kit for 3" driver - 8 ohms (with shims)

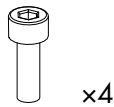

S1438
M4x14 hex

Prerequisite

Connector plate removed.

HF driver removed.

The HF driver assembly is placed on a flat surface in a dust-free environment.

See [CONNECTOR PLATE](#) (p.130).

See [HF DRIVER](#) (p.141).

Exploded view

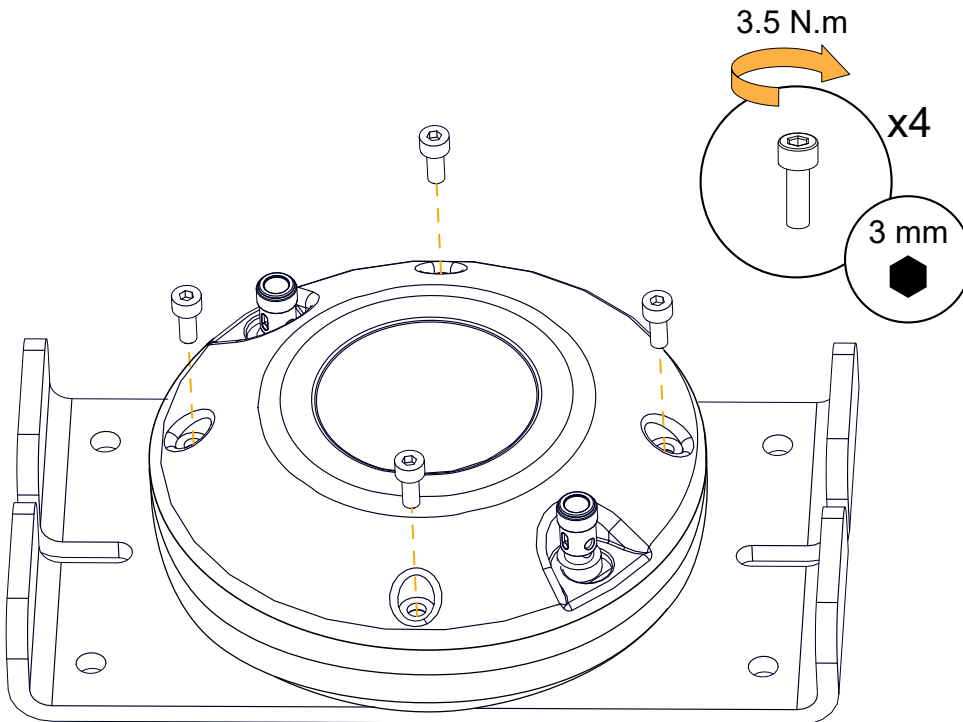

Disassembly

Procedure

1. Remove the four screws securing the cover.
Use the 3 mm hex bit.
2. Remove the cover.
3. Carefully remove the diaphragm.
Note the position of the part.
4. If there are shims on the dome, carefully remove them.
Take note of how many and what kind of shims are present.



Reassembly

About this task



For safety reasons, always use the new screws and spare parts provided in the KR.

Procedure

1. Clean the dome and the air gap.
Use a blower or double face adhesive tape to remove any particle.
 Make sure the air gap is perfectly clean before moving to the next step.
2. Place the same kind and number of shims that were initially present.
3. Carefully place the diaphragm.
Use the cable connectors as reference points.
4. Secure the cover to the speaker with the four screws.
 - a)  Gradually tighten the screws following a star pattern.

Gradually tighten each screw manually with the Allen wrench n°3.
 - b) Tighten the screws in the same order with the torque screwdriver.
Use the 3 mm hex bit and set the torque to 3.5 Nm.

What to do next

Perform the [Acoustical check](#) (p.57) procedures.

TEMPORARY MEASURE FOR K2 REAR AND FRONT RIGGING PINS

Repair kit

KR PIN1394

Kit 2 x pin 1394

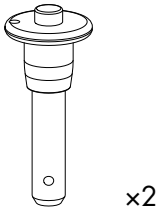

1394

ball-locking pin $\text{\O}3/8''$ with lanyard

KR PIN163

Kit K1 6 ball head pins

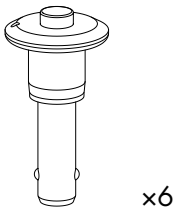

163

ball-locking pin $\text{\O}1/2''$ with lanyard



Contact your Certified Provider to finalize the ball-locking pins installation.

Inspect the ball-locking pins before operation.

Store the ball-locking pins in their storage slots when not in use.

Use the provided ball-locking pins for the rear and front rigging.

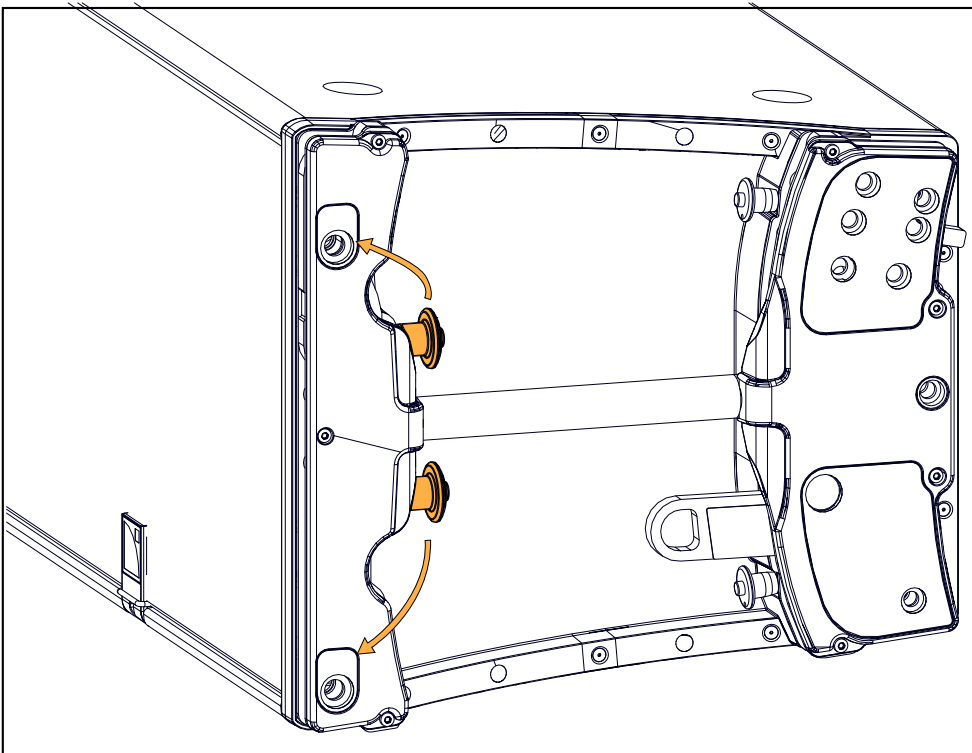

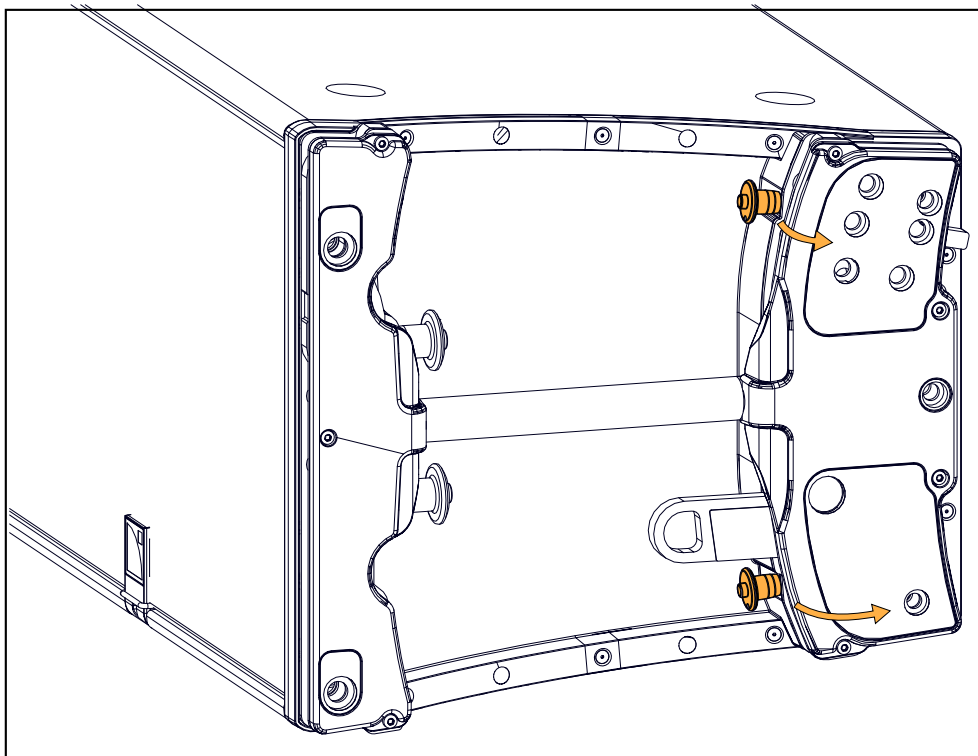

K1-SB

Disassembly and Reassembly procedures

In order to operate, follow the order outlined here.

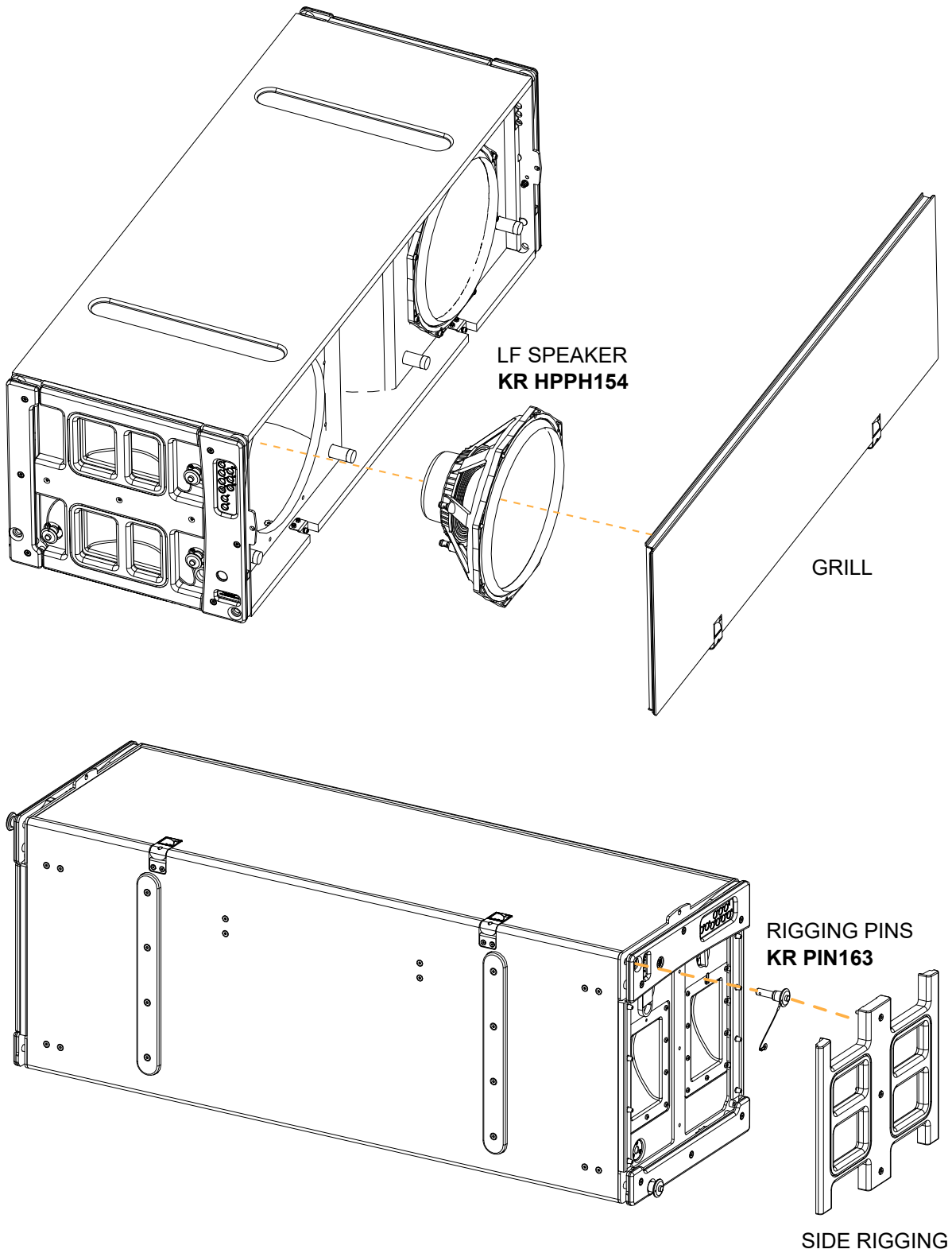

D/R - GRILL**Tools**

- torque screwdriver
- 4 mm hex bit

Repair kit**KR HPPH154**

Kit HP PH154 Speaker 15" - 8 ohms

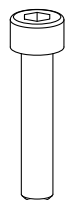

x2

S100155

M5x25 hex



x2

S158

plain washer Ø5 mm

Prerequisite

The enclosure is placed on its top.

Exploded view

For safety reasons, always use the new screws and spare parts provided in the KR.
If no new screws are available, use blue threadlocker.

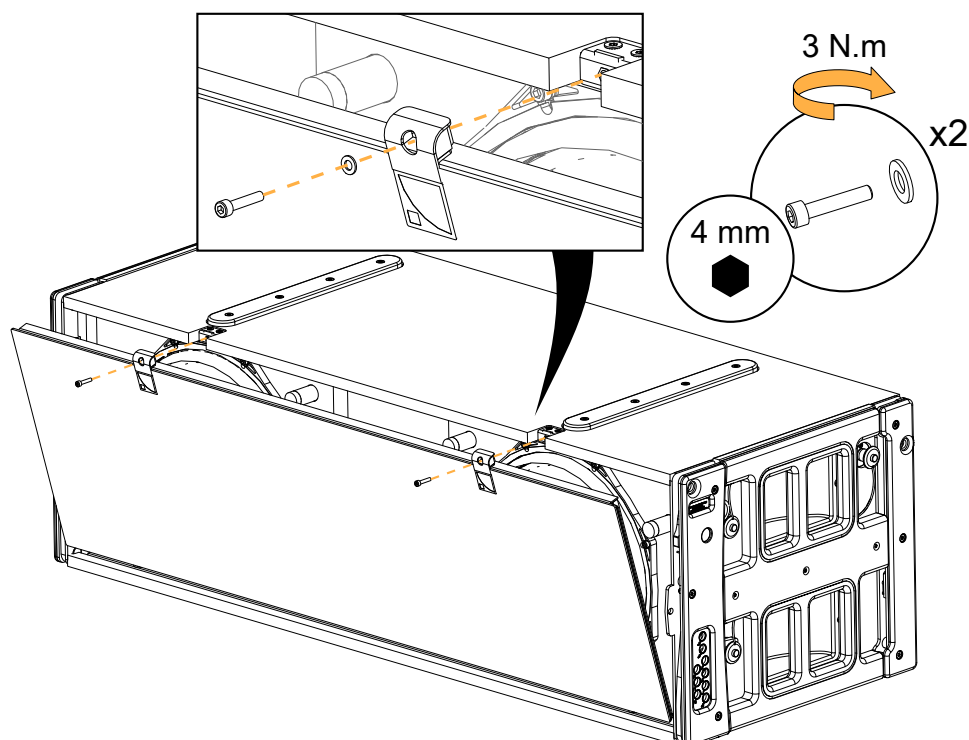

D/R - LF SPEAKER

Tools

- torque screwdriver
- 5 mm hex bit

Repair kit

KR HPPH154

Kit HP PH154 Speaker 15" - 8 ohms

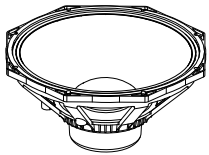

x1

300

15" speaker - 8 ohms



x8

S100054

M6x30 hex



* The screws and fasteners are also provided in the KR HPPH154 (Kit HP PH154 Speaker 15" - 8 ohms).

Prerequisite

Grill disassembled.

See [GRILL](#) (p.149).

Exploded view



For safety reasons, always use the new screws and spare parts provided in the KR.

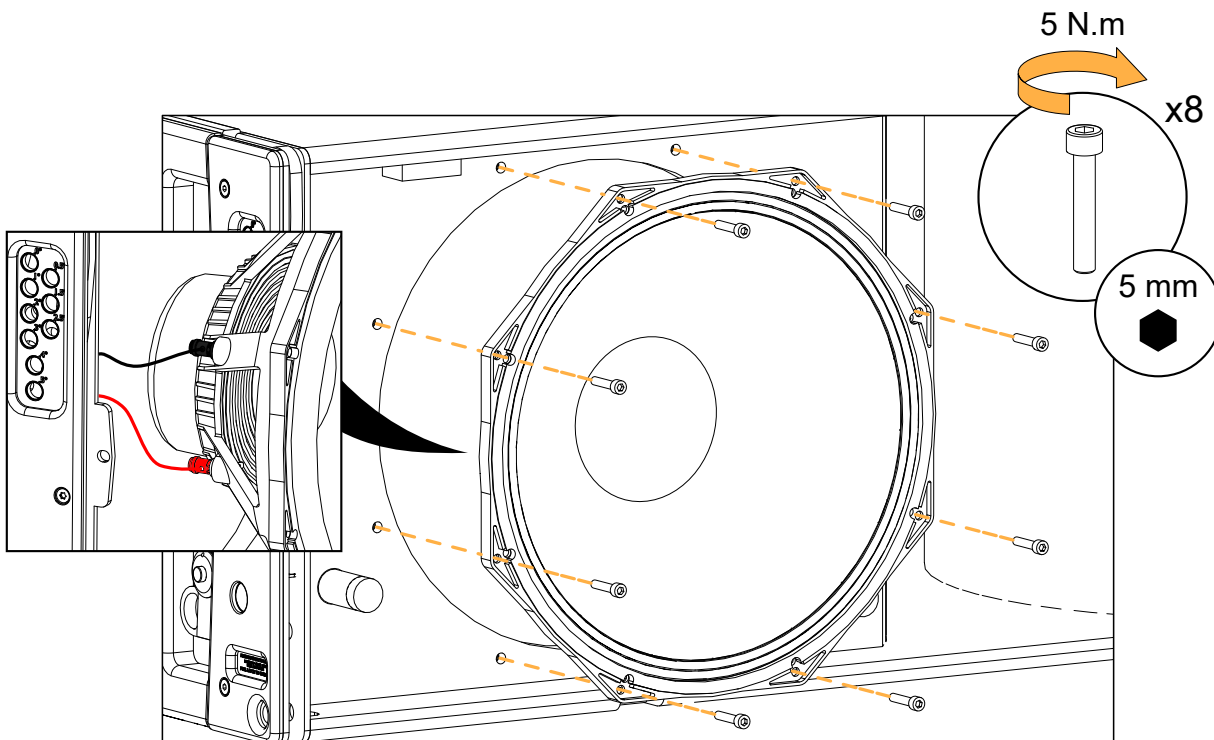

D/R - SIDE RIGGING PROTECTION

Tools

- torque screwdriver
- T30 Torx bit

Consumables

- blue threadlocker

Exploded view

 Save the screws and fasteners for reassembly.

Use blue threadlocker.

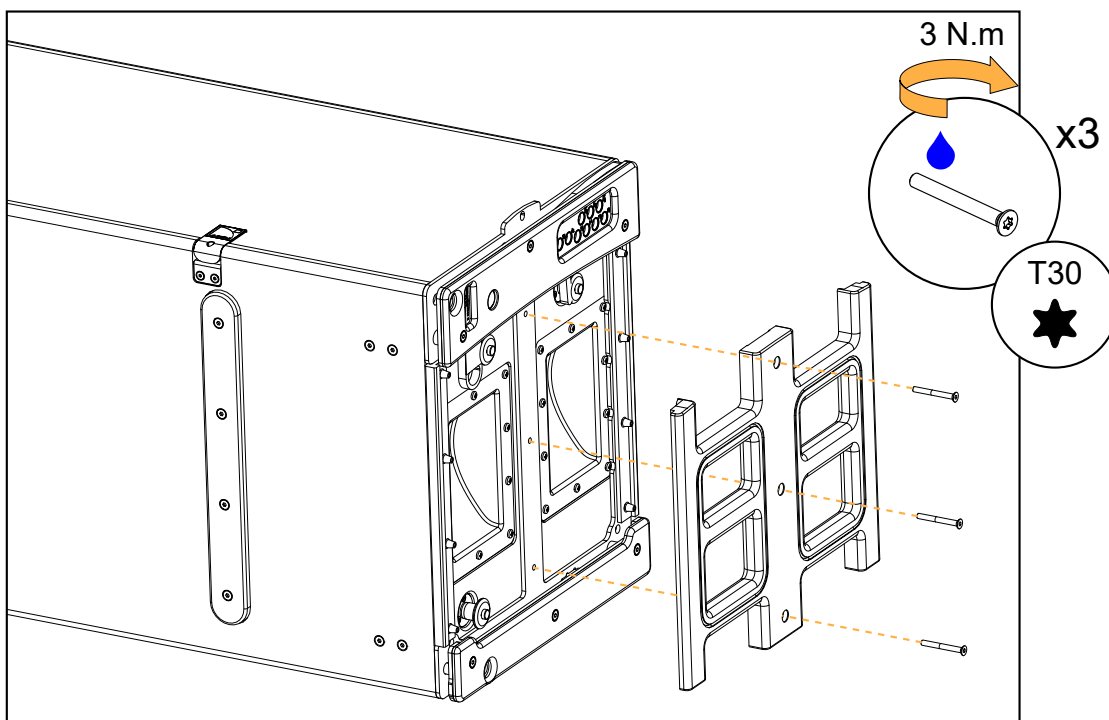

D/R - RIGGING PINS

Tools

- torque screwdriver
- T20 Torx bit

Repair kit

KR PIN163

Kit K1 6 ball head pins

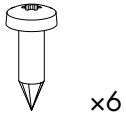

S101

M4.5x16 Torx

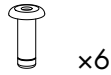

S142

M4x10 rivet

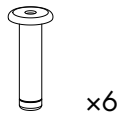

S254

M4.8x18 rivet



S158

plain washer Ø5 mm

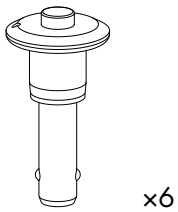

163

ball-locking pin Ø1/2" with lanyard



The S142, S254, and S158 are not used in this procedure.

Prerequisite

Side rigging protection removed.

See [SIDE RIGGING PROTECTION](#) (p.151).

Exploded view

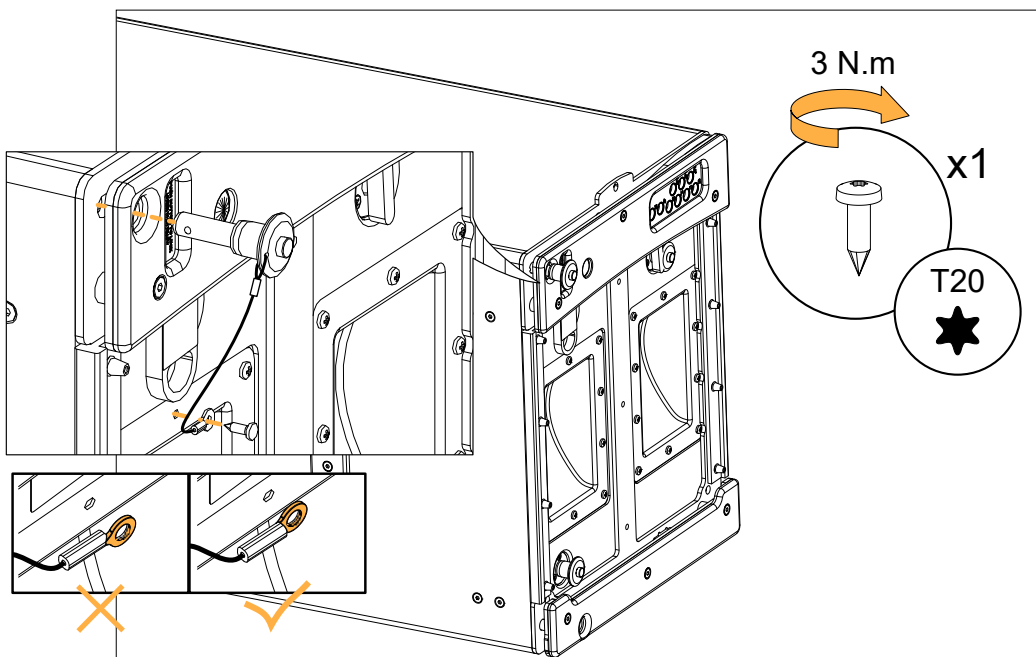

SB28

Disassembly and Reassembly procedures

In order to operate, follow the order outlined here.

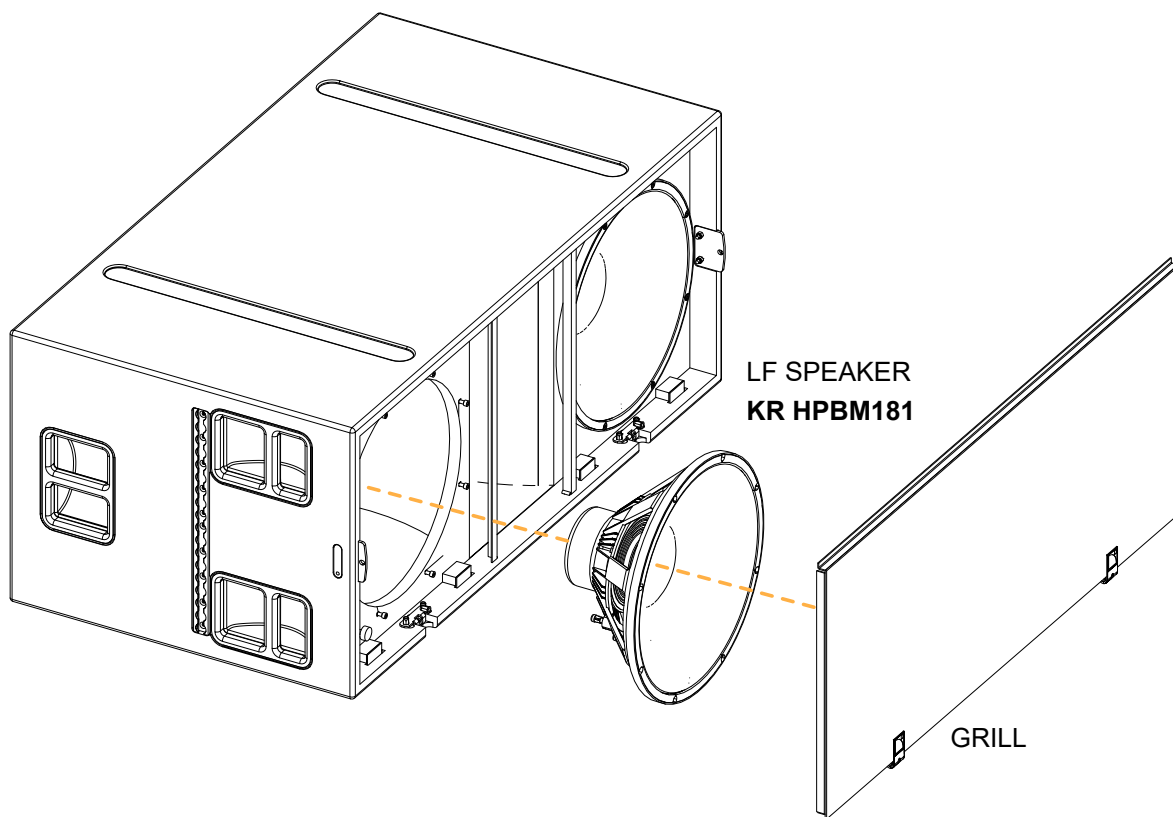

D/R - GRILL

Tools

- torque screwdriver
- 5 mm hex bit

Consumables

- blue threadlocker

Exploded view

 Save the screws and fasteners for reassembly.

Use blue threadlocker.

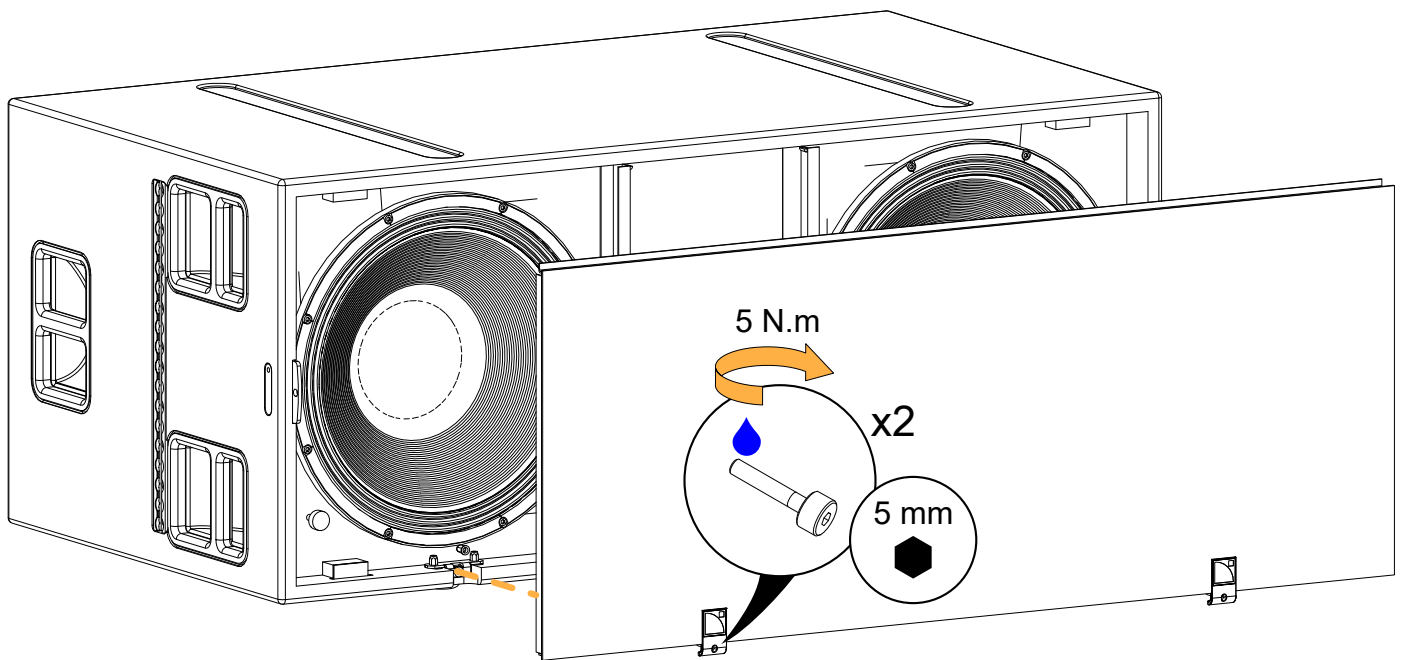

D/R - LF SPEAKER**Tools**

- torque screwdriver
- 5 mm hex bit

Repair kit**KR HPBM181**

Kit HP BM181 Speaker 18"

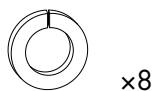

x8

S154

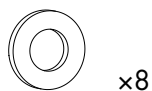
single coil spring washer
Ø6 mm

x8

S160

plain washer Ø6 mm

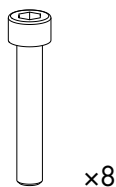

x8

S197

M6x35 hex

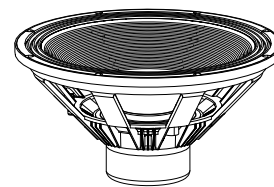

x1

FT807

18" driver - 8 ohms

Prerequisite

Grill disassembled.

See [GRILL](#) (p.154).**Exploded view**

For safety reasons, always use the new screws and spare parts provided in the KR.



Gradually tighten the screws following a star pattern.

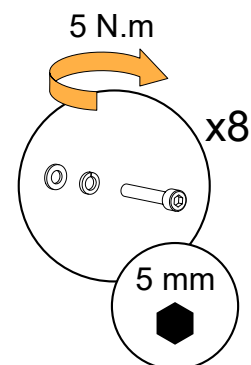
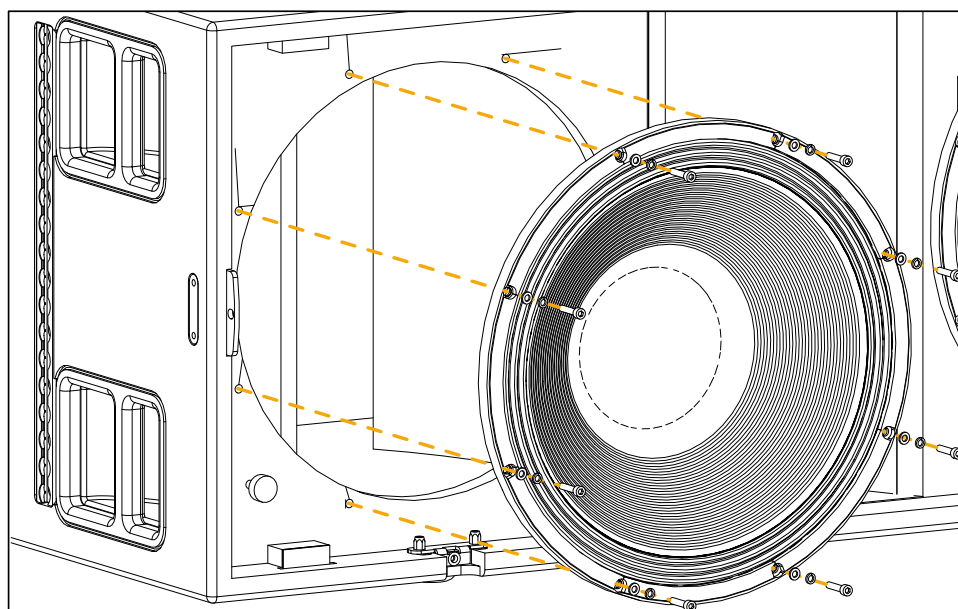

K2-BUMP

Disassembly and Reassembly procedures

In order to operate, follow the order outlined here.

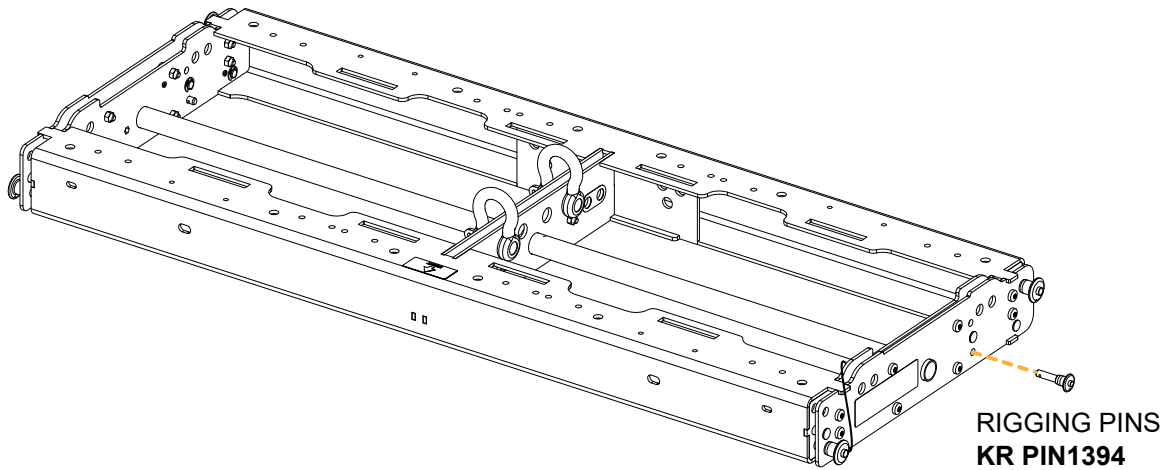
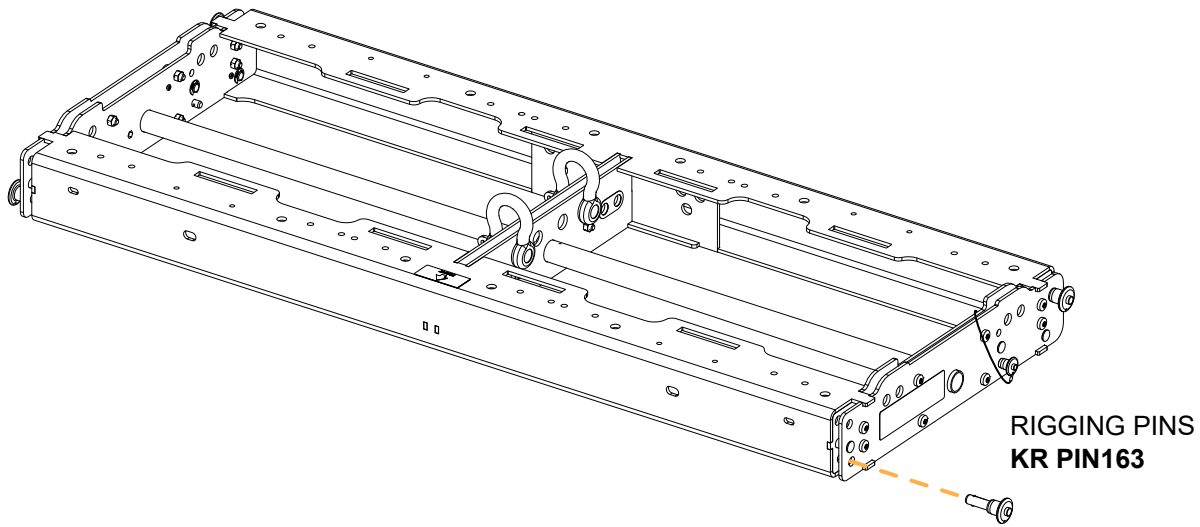

D/R - RIGGING PINS**Tools**

- riveting pliers

Repair kit**KR PIN163**

Kit K1 6 ball head pins

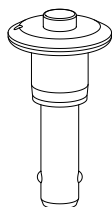

x6

163

ball-locking pin Ø1/2"with lanyard



x6

S142

M4x10 rivet

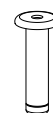

x6

S254

M4.8x18 rivet



The S254 are not used (represented for comparison)

Exploded view

For safety reasons, always use the new screws and spare parts provided in the KR.



Position the flat side of the steel tab toward the rigging element.

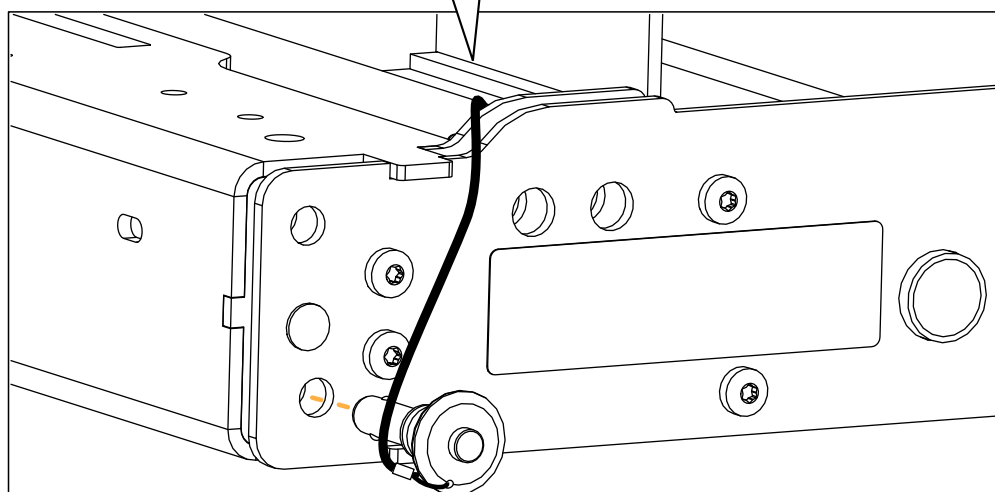
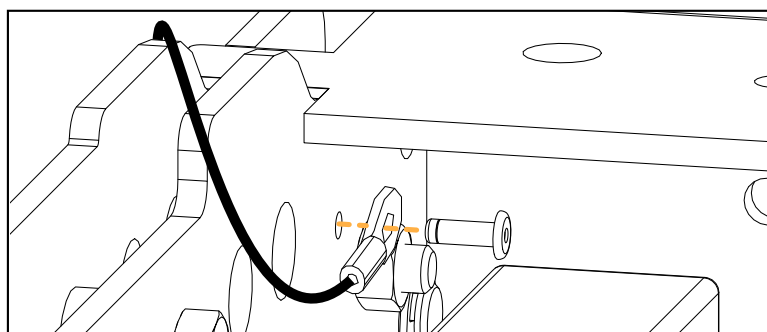

D/R - RIGGING PINS

Tools

- riveting pliers

Repair kit

KR PIN1394

Kit 2 x pin 1394

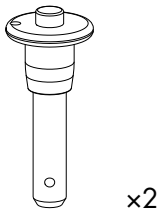

x2

1394

ball-locking pin Ø3/8" with lanyard

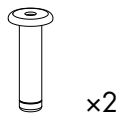

x2

S254

M4.8x18 rivet

Exploded view



For safety reasons, always use the new screws and spare parts provided in the KR.



Position the flat side of the steel tab toward the rigging element.

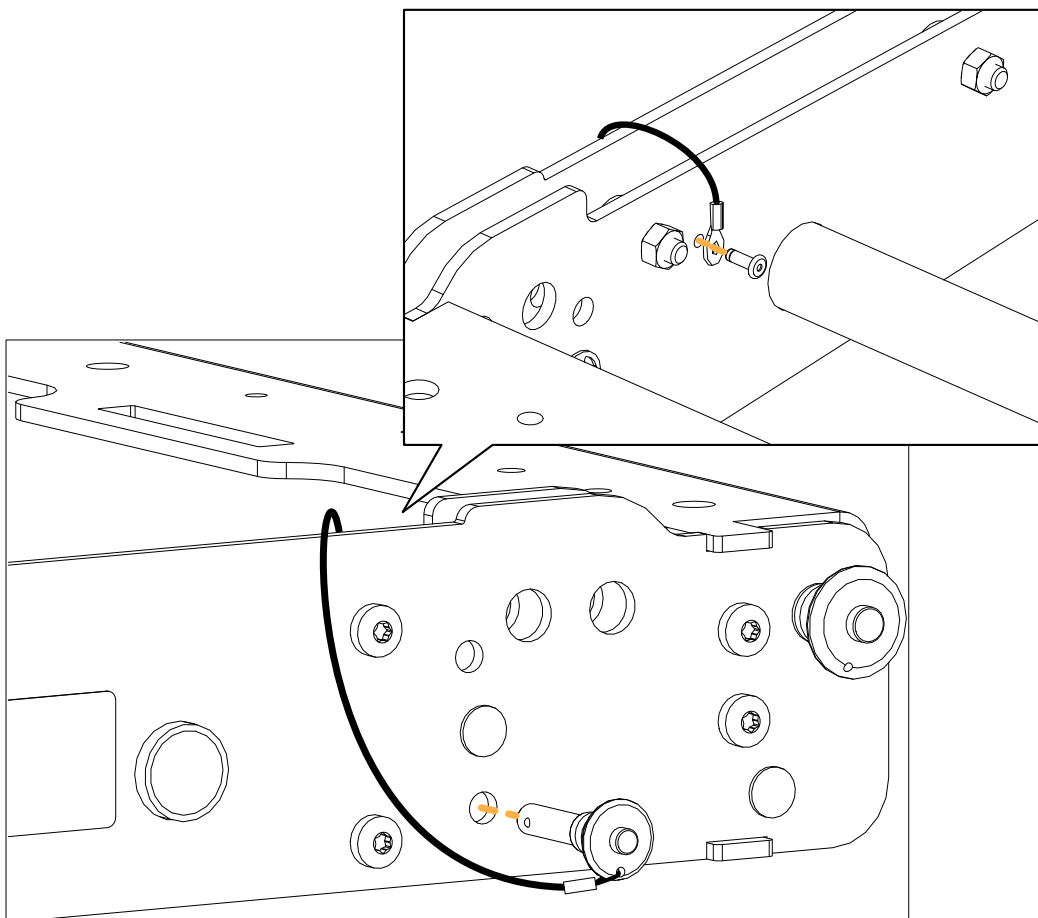

K2-BAR

Disassembly and Reassembly procedures

In order to operate, follow the order outlined here.

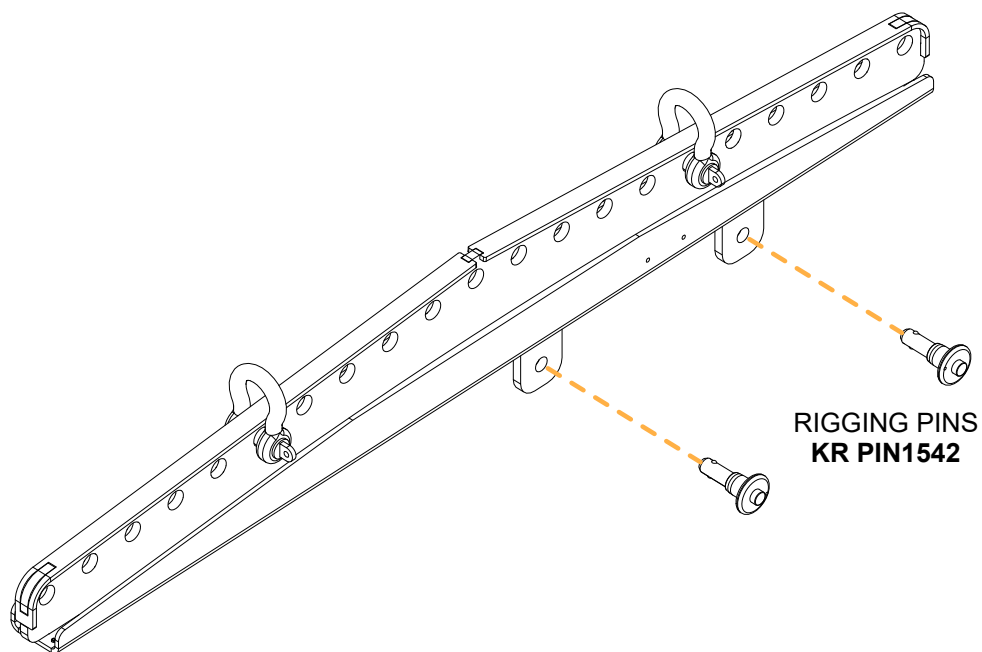

D/R - RIGGING PINS

Tools

- riveting pliers

Repair kit

KR PIN1542

Kit 2 x pin 1542

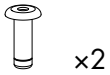

x2

S142

M4x10 rivet

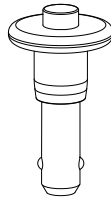

x2

1542

round head ball-locking pin $\text{\O}5/8''$ with lanyard

Exploded view



For safety reasons, always use the new screws and spare parts provided in the KR.

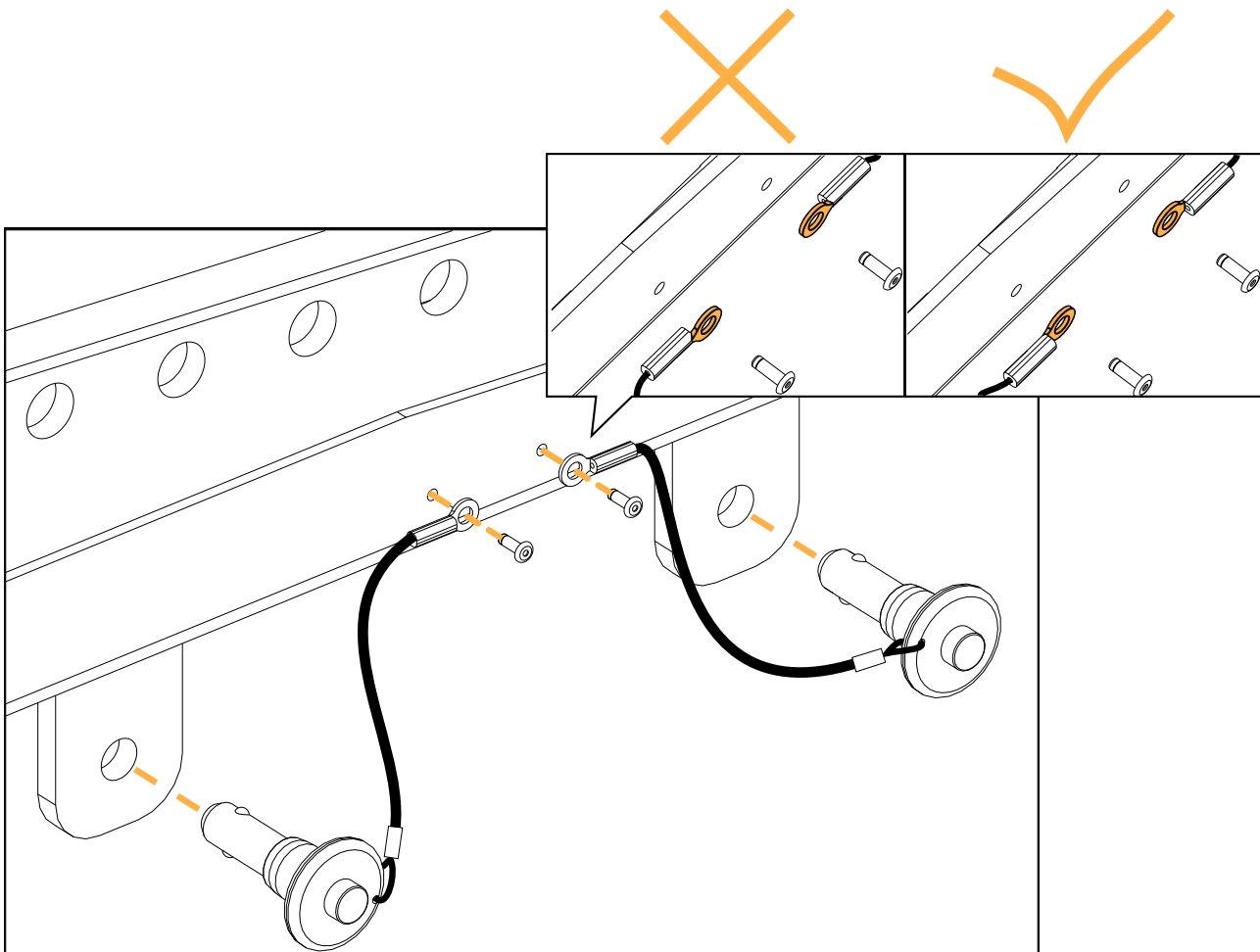

Specifications

K2 specifications

Description	3-way full-range active WST enclosure, quad-amplified by LA4X / LA8 / LA12X
Usable bandwidth (-10 dB)	35 Hz - 20 kHz ([K2 70])
Maximum SPL¹	147 dB ([K2 70])
Nominal directivity (-6 dB)	horizontal: 110°/70° symmetric or 90° asymmetric (35°/55° or 55°/35°) vertical: dependent upon the number of elements and the line source curvature
Transducers	LF: 2 × 12" cone drivers MF: 4 × 6.5" cone drivers HF: 2 × 3" diaphragm compression drivers
Acoustical load	LF: bass-reflex, L-Vents MF: bass-reflex HF: DOSC waveguide
Nominal impedance	LF: 2 × 8 Ω MF: 8 Ω HF: 16 Ω
Connectors	IN: 1 × 8-point PA-COM LINK: 1 × 8-point PA-COM
Rigging and handling	4-point captive rigging system inter-enclosure angles: 0.25°, 1°, 2°, 3°, 4°, 5°, 7.5° or 10°
Weight (net)	56 kg / 123.2 lb
Cabinet	premium grade Baltic birch plywood
Front	coated steel grill acoustically neutral 3D fabric
Rigging components	high grade steel with anti-corrosion coating
Finish	dark grey brown Pantone 426 C
IP	IP55

¹ Peak level measured at 1 m under free field conditions using pink noise with crest factor 4 (preset specified in brackets).

K2 dimensions

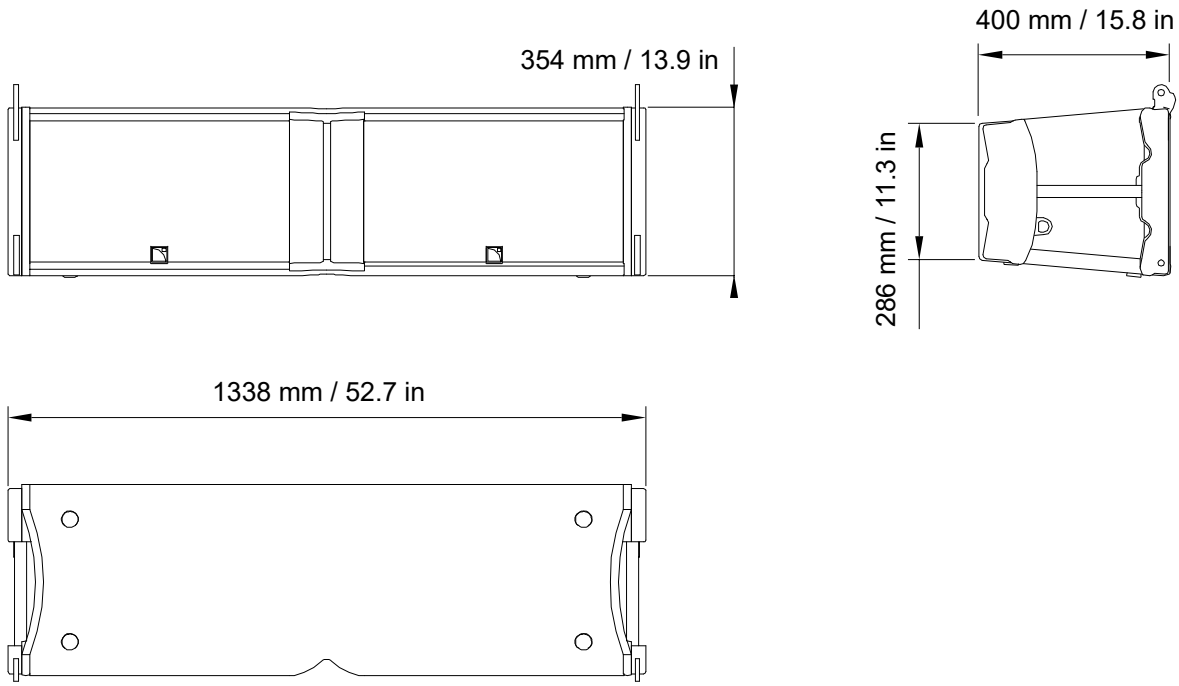

K1-SB specifications

Description	K1 system subwoofer 2×15", amplified by LA8LA12X
Low frequency limit (-10 dB)	30 Hz ([K1SB_60])
Maximum SPL¹	145 dB ([K1SB_X])
Transducers	2 × 15" cone drivers
Acoustical load	bass-reflex, L-Vents
Nominal impedance	4 Ω
Connectors	IN: 1 × 4-point speakON
Rigging and handling	captive rigging system 4-point rigging system inter-enclosure angles: 0°, 0.5°, 1°, 1.5°, 2°, 2.5°, 3°, 4° or 5° 4 handles integrated into the cabinet
Weight (net)	83 kg / 183 lb
Cabinet	premium grade Baltic birch plywood
Front	coated steel grill acoustically neutral 3D fabric
Rigging components	high grade steel with anti-corrosion coating
Finish	dark grey brown Pantone 426 C pure white RAL 9010
IP	IP45

¹ Peak level at 1 m under half space conditions using pink noise with crest factor 4 (preset specified in brackets).

K1-SB dimensions

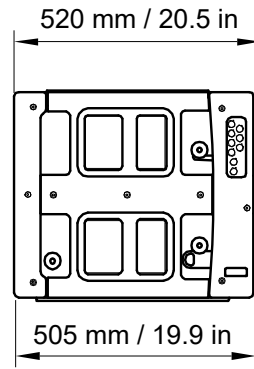
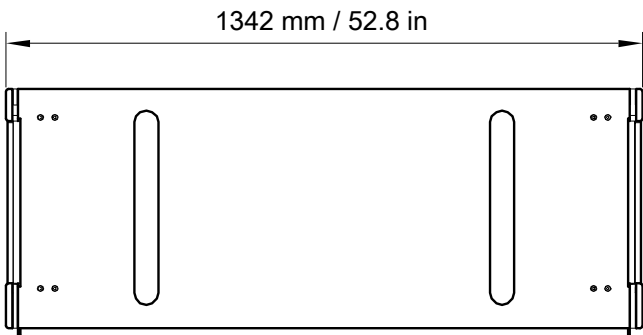
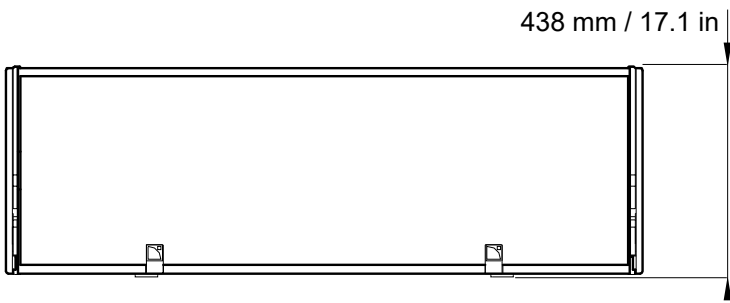
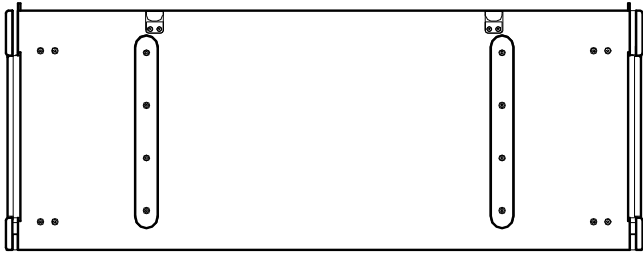

KS28 specifications

Description	Flyable subwoofer 2 x 18" , amplified by LA12X
Low frequency limit (-10 dB)	25 Hz ([KS28_100])
Maximum SPL¹	143 dB ([KS28_100])
Directivity	standard or cardioid
Transducers	2 x 18" neodymium cone drivers
Acoustical load	bass-reflex, L-Vents
Nominal impedance	4 Ω
Connectors	IN: 1 x 4-point speakON
Rigging and handling	flush-fitting 2-point rigging system 6 ergonomic handles 2 ground runners 8 side runners
Weight (net)	79 kg / 174 lb
Cabinet	premium grade Baltic beech and birch plywood
Front	coated steel grill acoustically neutral 3D fabric
Rigging components	high grade steel
Finish	dark grey brown Pantone 426 C

¹ Peak level at 1 m under half space conditions using pink noise with crest factor 4 (preset specified in brackets).

KS28 dimensions

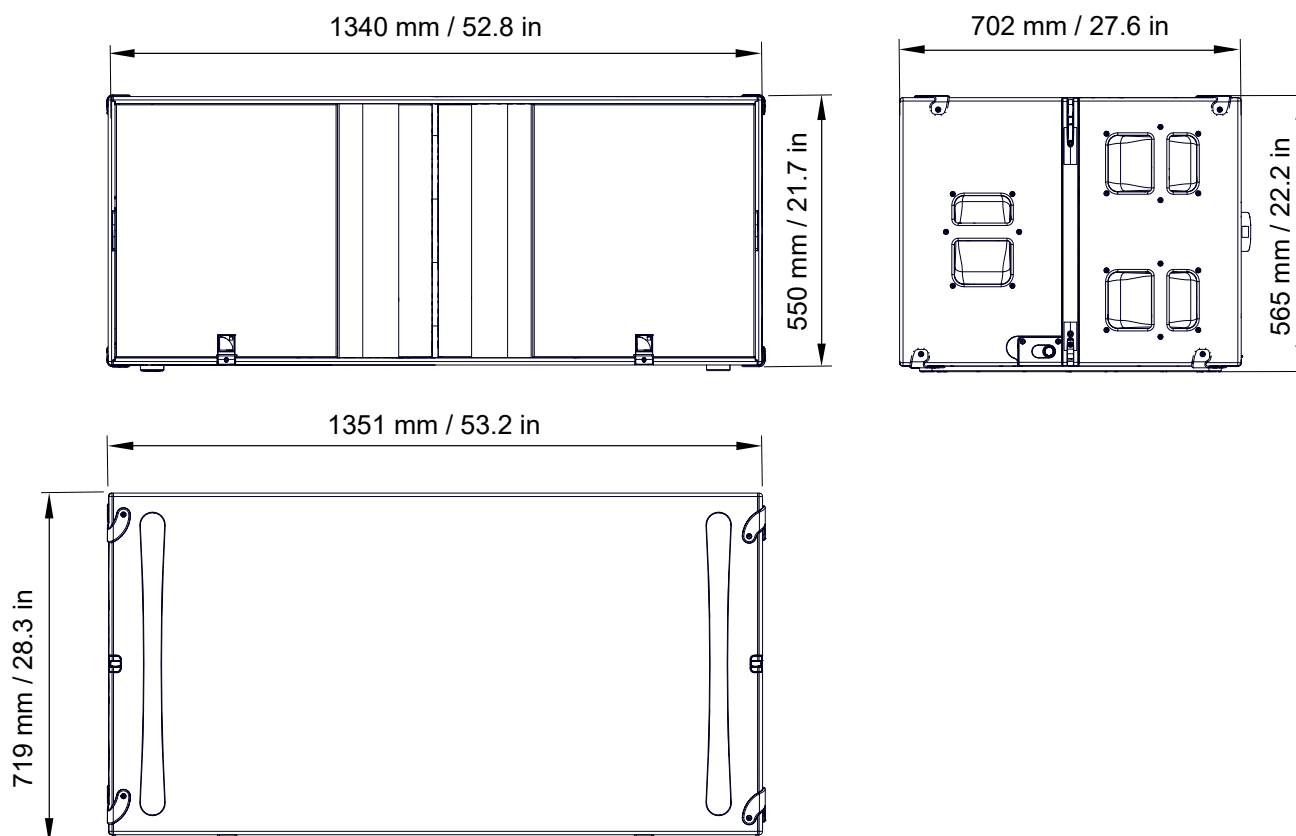

SB28 specifications

Description	High power subwoofer: 2 x 18" , amplified by LA8
Low frequency limit (-10 dB)	25 Hz ([SB28_100])
Maximum SPL¹	142 dB ([SB28_100])
Directivity	standard or cardioid
Transducers	2 x 18" neodymium direct-radiating
Acoustical load	bass-reflex, L-Vents
Nominal impedance	4 Ω
Connectors	IN: 1 x 4-point speakON
Rigging and handling	integrated rigging system handles integrated into the cabinet
Weight (net)	93 kg / 205 lb
Cabinet	premium grade Baltic birch plywood
Front	coated steel grill acoustically neutral 3D fabric
Rigging components	high grade steel with anti-corrosion coating
Finish	dark grey brown Pantone 426 C
IP	55

¹ Peak level at 1 m under half space conditions using pink noise with crest factor 4 (preset specified in brackets).

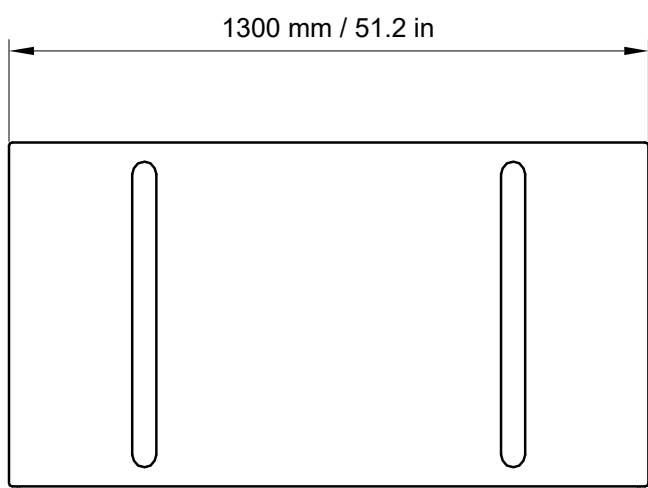
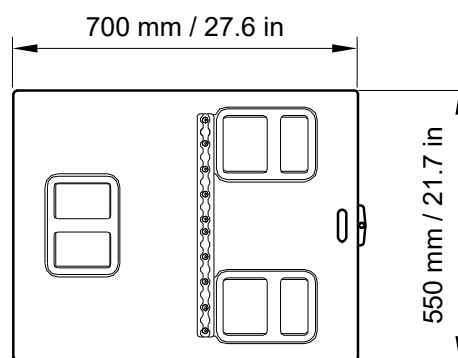
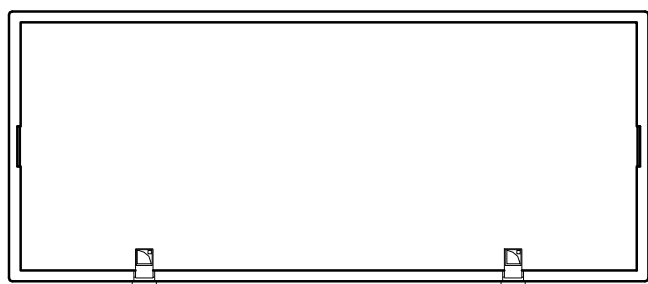
SB28 dimensions

K2-BUMP specifications

Description	Structure for flying K2 arrays (incl. 1 extension sling + 1 laser adapter) 2 x Ø19 mm shackles WLL 3.25 t
Weight (net)	42.3 kg / 93.3 lb
Material	high grade steel with anti-corrosion coating

K2-BUMP dimensions

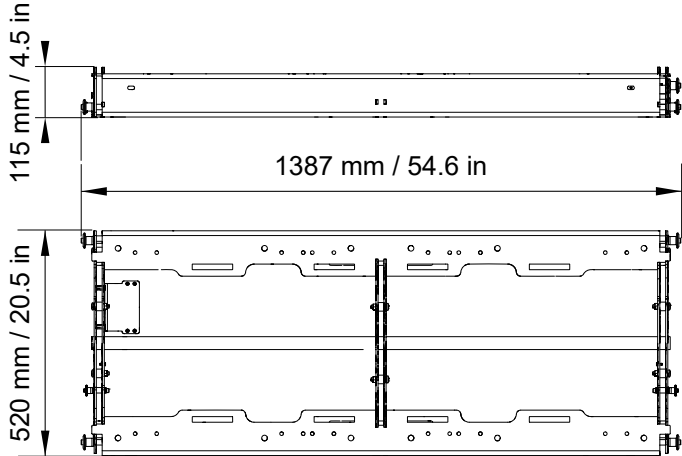

K-BUMPFLIGHT specifications

Description	Modular flight case for 2 K1-BUMP or 2 K2-BUMP 12 pieces of adhesive foam
Weight (net)	105 kg / 231.5 lb

K-BUMPFLIGHT dimensions

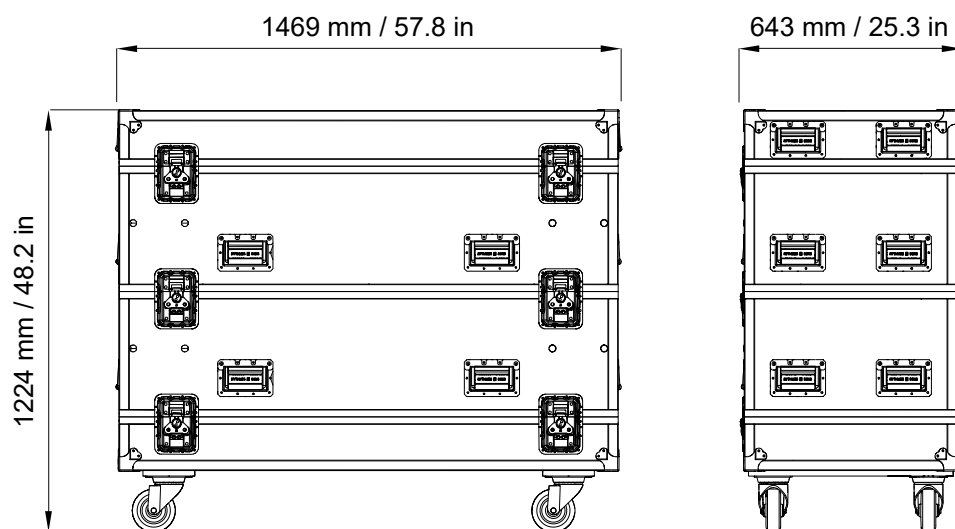

K2-BAR specifications

Description	Extension bar for K2-BUMP 2 × Ø19 mm shackles WLL 3.25 t
Weight (net)	17 kg / 37.5 lb
Material	high grade steel with anti-corrosion coating

K2-BAR dimensions

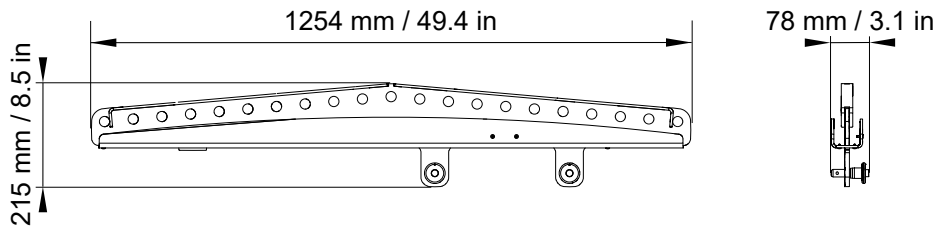

K2-LINK specifications

Description	Rigging accessory for rear attachment of K2 below K1
Weight (net)	1.8 kg / 4 lb
Material	high grade steel with anti-corrosion coating

K2-LINK dimensions

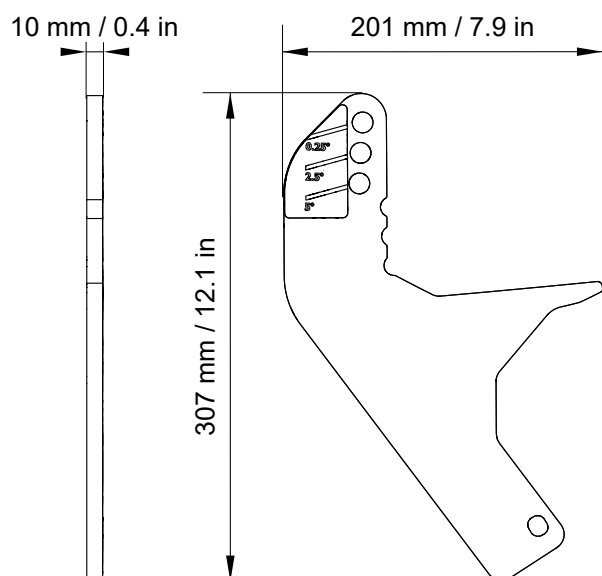

K2-RAKMOUNT specifications

Description	4 mounting cradle for LA-RAK (incl. rack stabilizer)
Weight (net)	3.3 kg / 7.3 lb (cradle) 2.2 kg / 4.9 lb (stabilizer)
Material	high grade steel with anti-corrosion coating

K2-RAKMOUNT dimensions

Rail

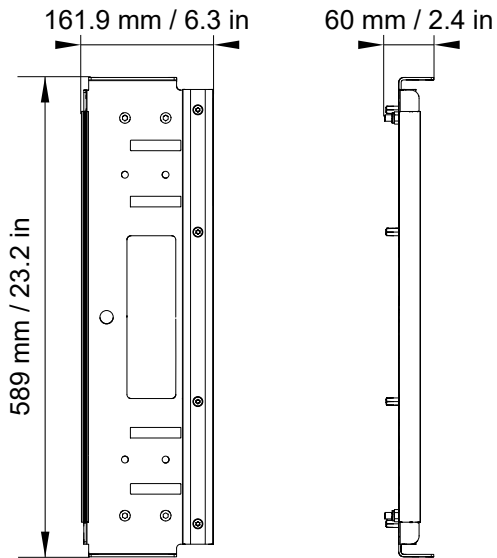

Stabilizer

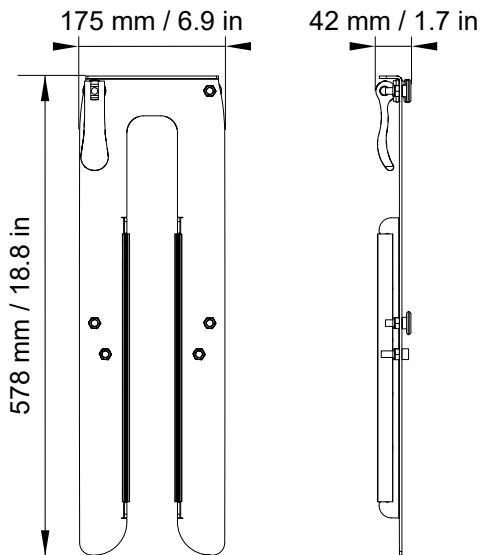

K1-DELTA specifications

Description	Rigging accessory for rear attachment of 2 motors to K1-BUMP
Weight (net)	9.5 kg / 21 lb
Material	high grade steel with anti-corrosion coating

K1-DELTA dimensions

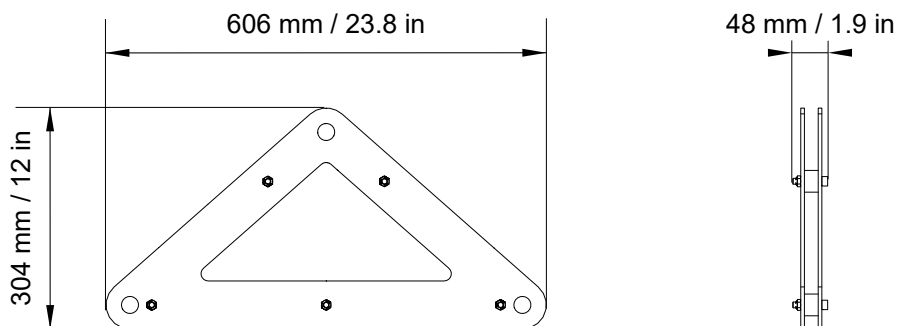

LA-SLING2T specifications

Description	Lifting chain (DIN EN 818-4) 2-leg , 8 mm
Material	high grade steel with anti-corrosion coating
Weight (net)	3.7 kg / 1.2 lb
Lifting chain (DIN EN 818-4)	2-leg, 8 mm
Steel grade	8
Nominal length incl. hooks	3.7 kg / 1.2 lb
Maximum sling angle β_{\max}	60°
Load rating	2.8 t for β : 0° - 45° 2 t for β : 46° - 60°

LA-SLING2T illustration

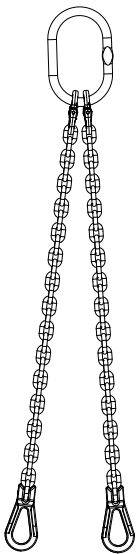

K1-BPCHAIN specifications

Description	Adjustable sling for K1-BUMP or K2-BUMP
Weight (net)	6.3 kg / 13.9 lb
Material	high grade steel with anti-corrosion coating

K1-BPCHAIN dimensions

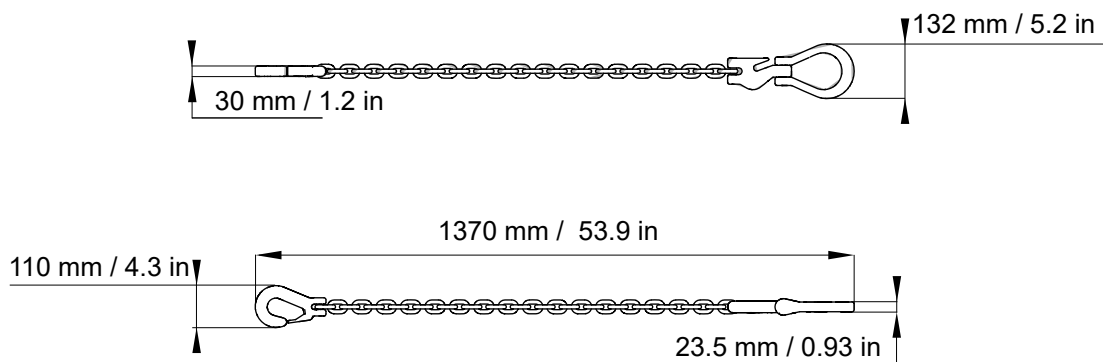

K2-RIGBAR specifications

Description	K2 rigging bar and pullback (Inc. LA-SLING2T)
Weight (net)	15.5 kg / 34.2 lb
Material	high grade steel with anti-corrosion coating

K2-RIGBAR dimensions

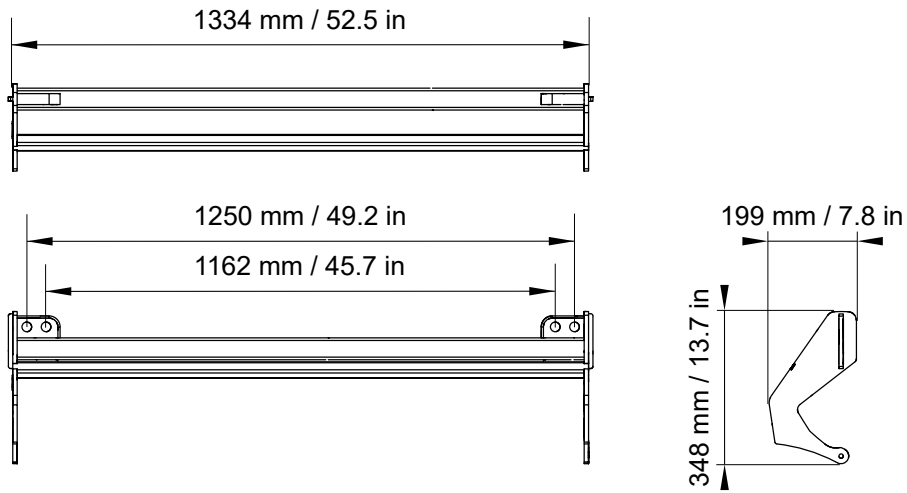

K2-CHARIOT specifications

Description	Chariot for 4 K2
Weight (net)	50 kg / 110.2 lb
Material	high grade steel with anti-corrosion coating

K2-CHARIOT dimensions

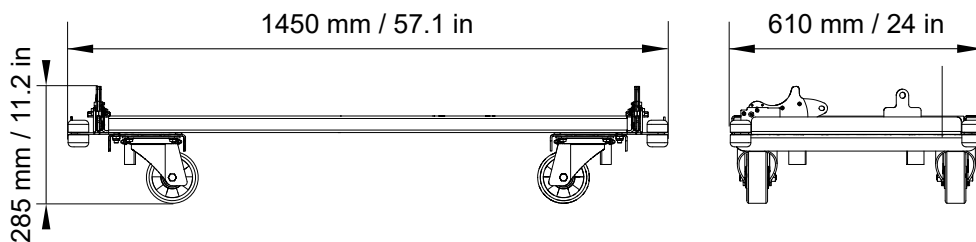

K2-JACK specifications

Description	4 tilt adjustment screw jacks + bar for K2-CHARIOT
Weight (net)	10.1 kg / 22.3 lb (for one stabilizer)
Material	high grade steel with anti-corrosion coating

K2-JACK dimensions

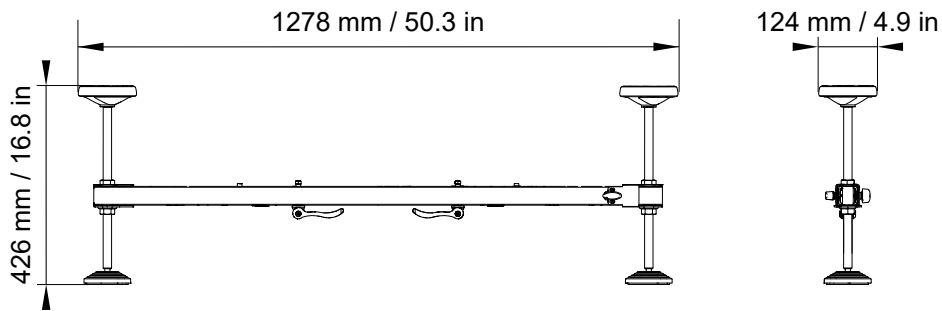

K2-LASERMOUNT specifications

Description	K2 laser support plate (compatible TEQSAS / SSE Prosight / Align Array / KSG)
Weight (net)	0.74 kg / 1.6 lb
Material	high grade steel with anti-corrosion coating

K2-LASERMOUNT dimensions

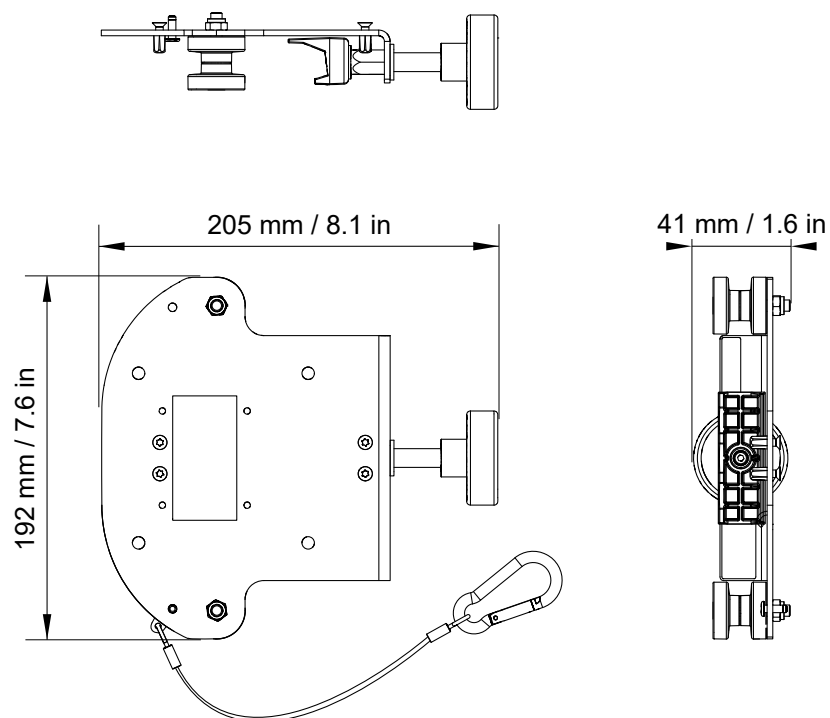

KARADOWNK2 specifications

Description	Flying bumper for rigging Kara under K2
Weight (net)	17 kg / 37 lb
Material	high grade steel with anti-corrosion coating

KARADOWNK2 dimensions

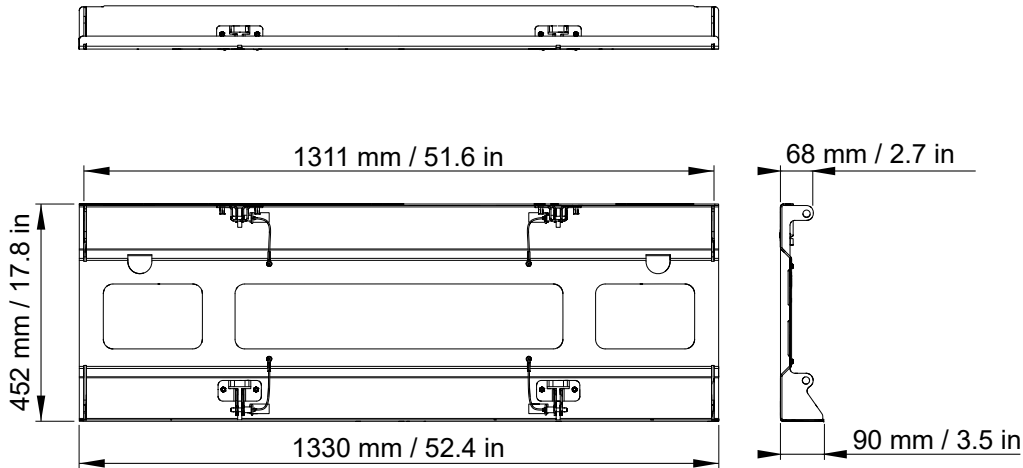

Pickup points guidelines

A K2 system can be lifted using one or two motors:

- One or two motors with K2-BUMP alone.
- Two motors with K2-BUMP and one K2-BAR.
- Two with K2-BUMP and two K2-BAR.

K2-BUMP with LA-RAK/LA-RAK II

With a single LA-RAK/LA-RAK II on top of a K2-BUMP, always implement a bridle suspension using two LA-SLING2T. With two LA-RAK/LA-RAK II on top of a K2-BUMP, always use the K2-RAKMOUNT stabilizer.

OK

Not OK

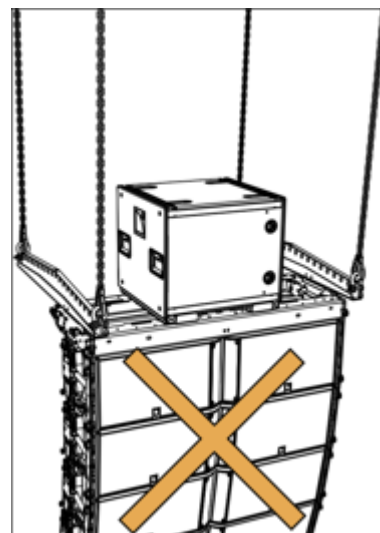
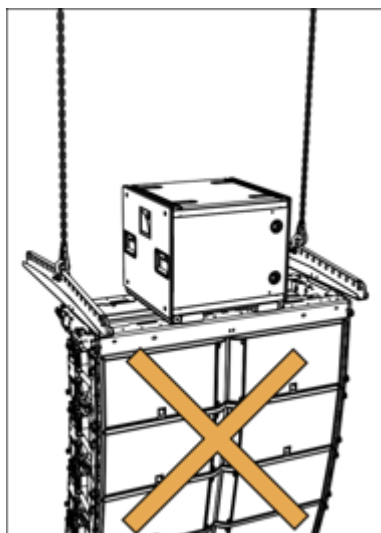
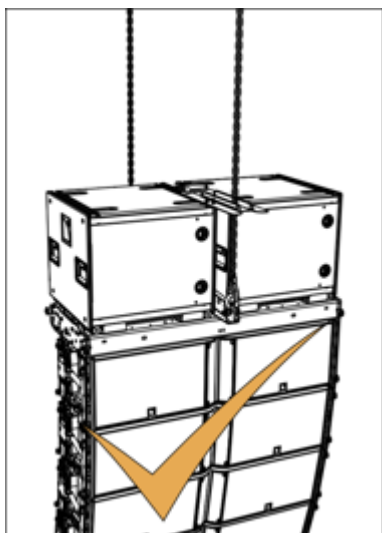
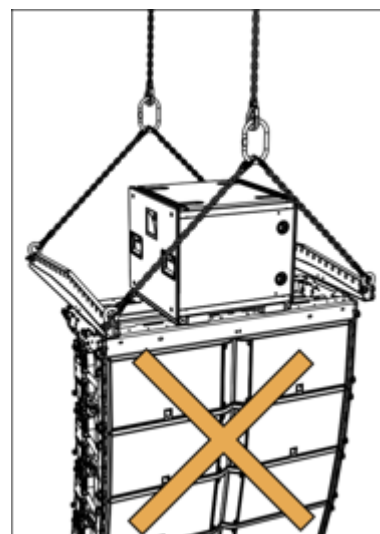
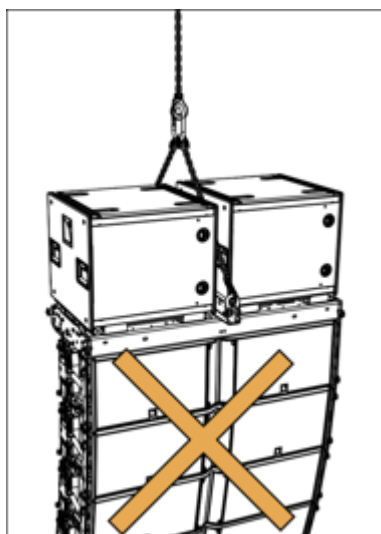
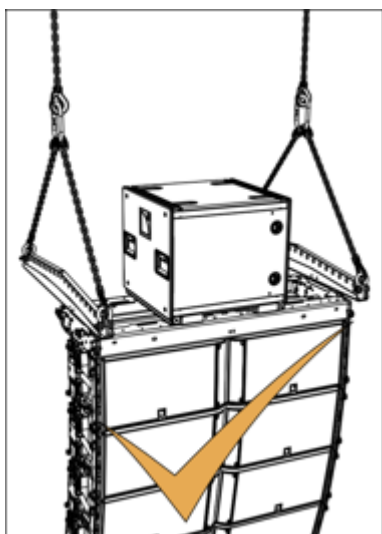

Use two LA-SLING2T to implement bridle hangs.

One leg of the LA-SLING2T must always be connected to the K2-BAR hole no 1 (i.e., the closest to the array). The other leg can be connected to holes no 11 to no 21.

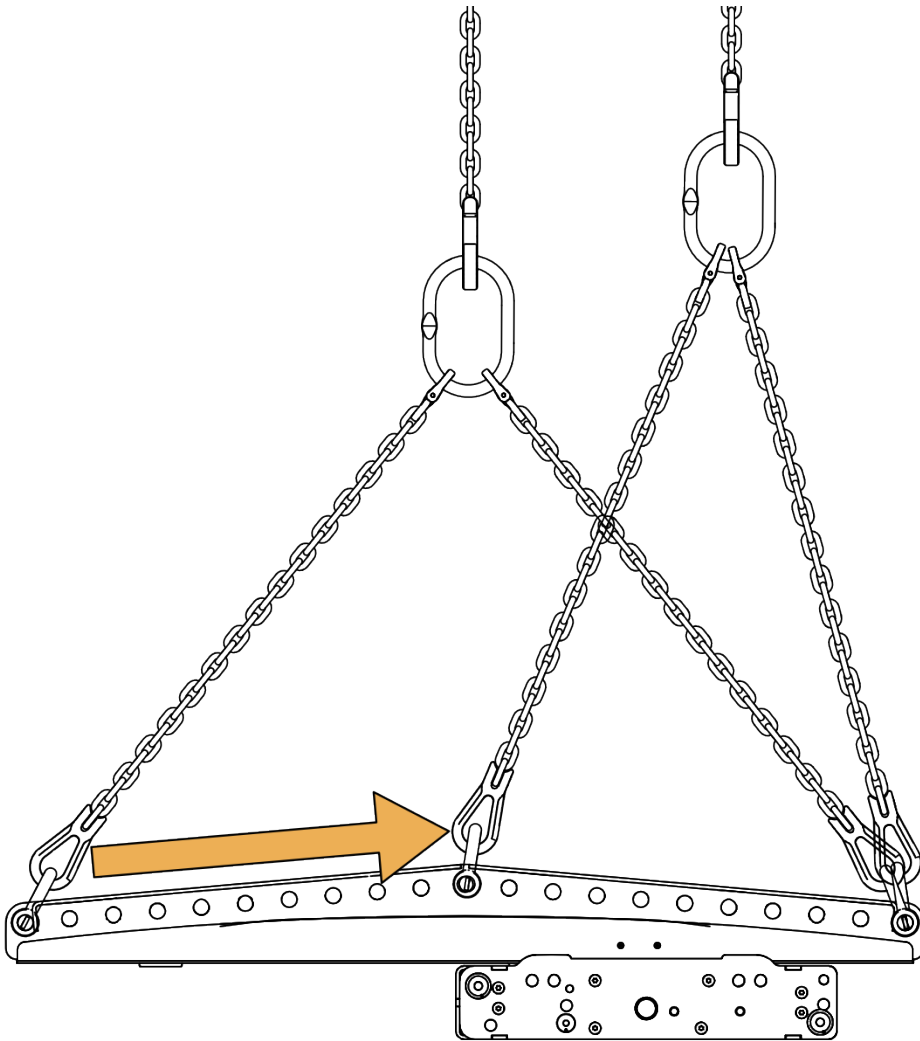

K2-BUMP with no LA-RAK/LA-RAK II

OK

Not OK

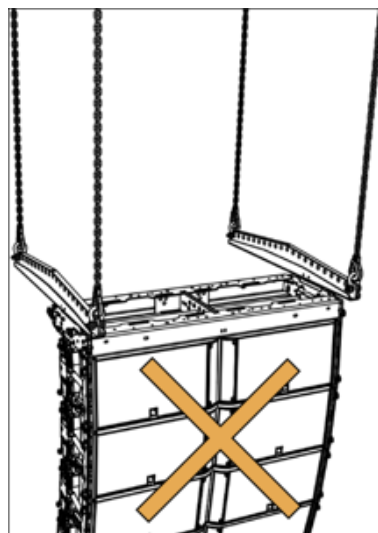
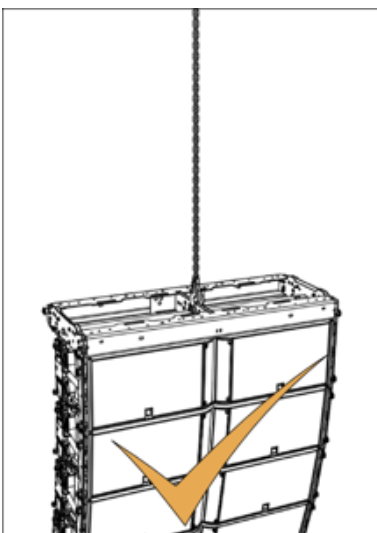
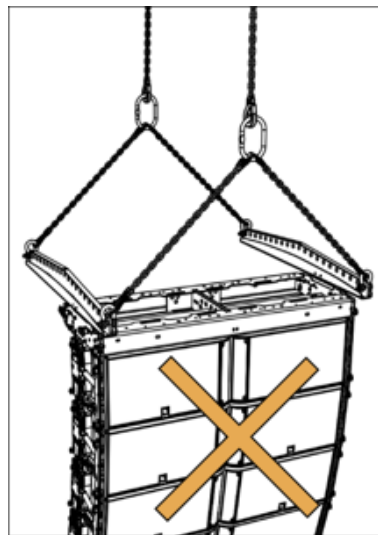
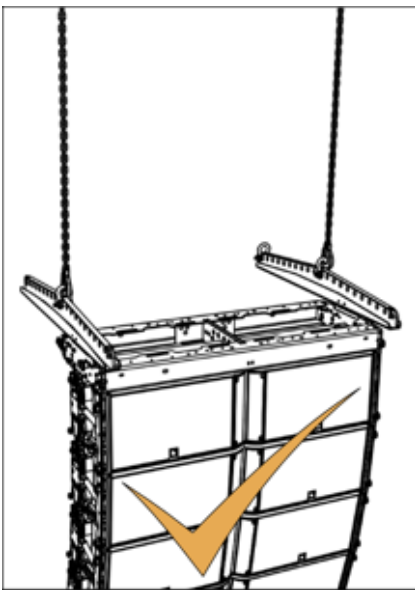
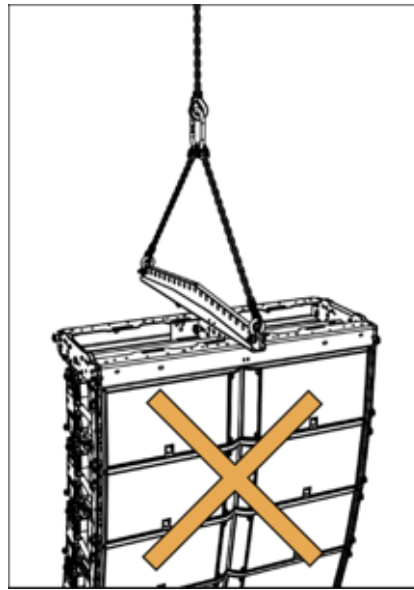
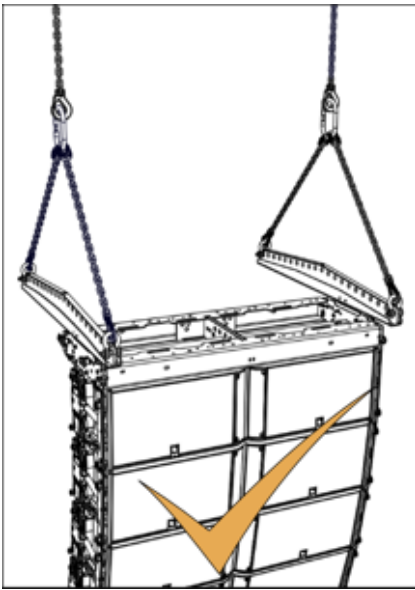

K1-DELTA for azimuth control

To control the azimuth of a flown K2 line, attach the K1-DELTA to the rear pickup point. The recommended space between the two lifting points is 1 m / 33 ft.

By adjusting the height of both pickup points you can adjust the azimuth angle from -10° to $+10^{\circ}$.

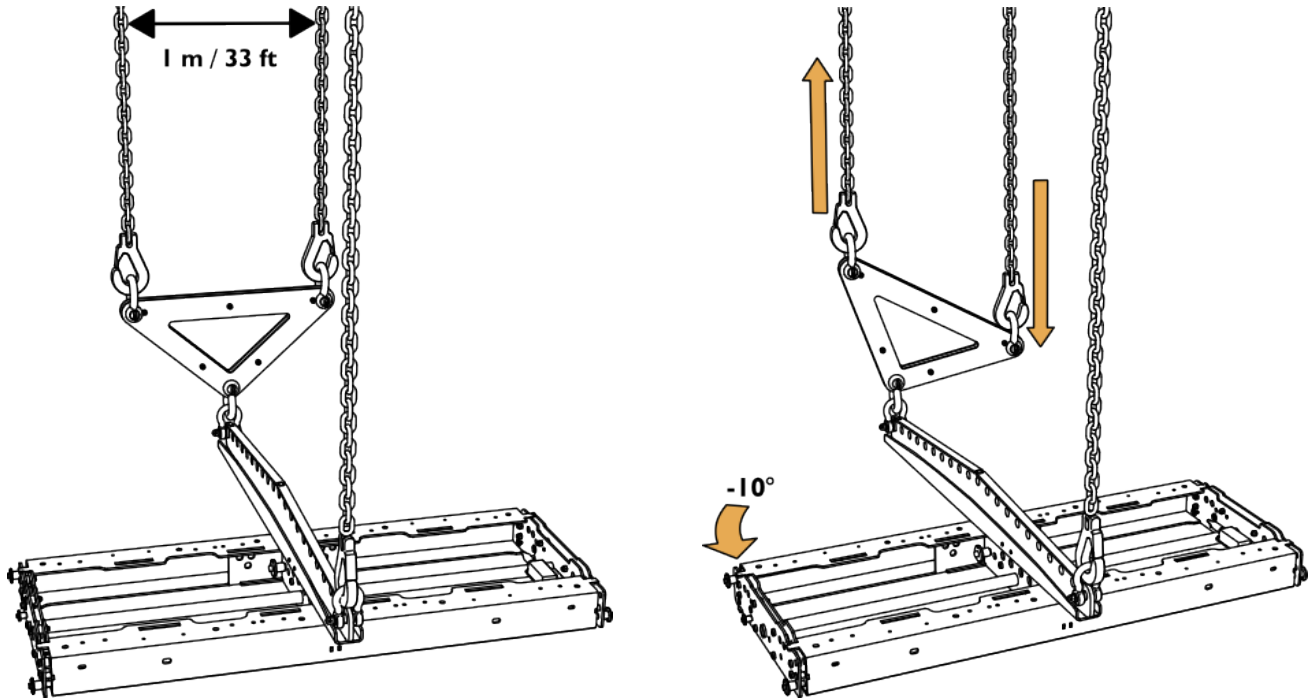

K1-BPCHAIN with a climbing hoist

With a climbing hoist you must use a K1-BPCHAIN adjustable sling to prevent the chain bag from hanging in front of the top enclosures of the array.

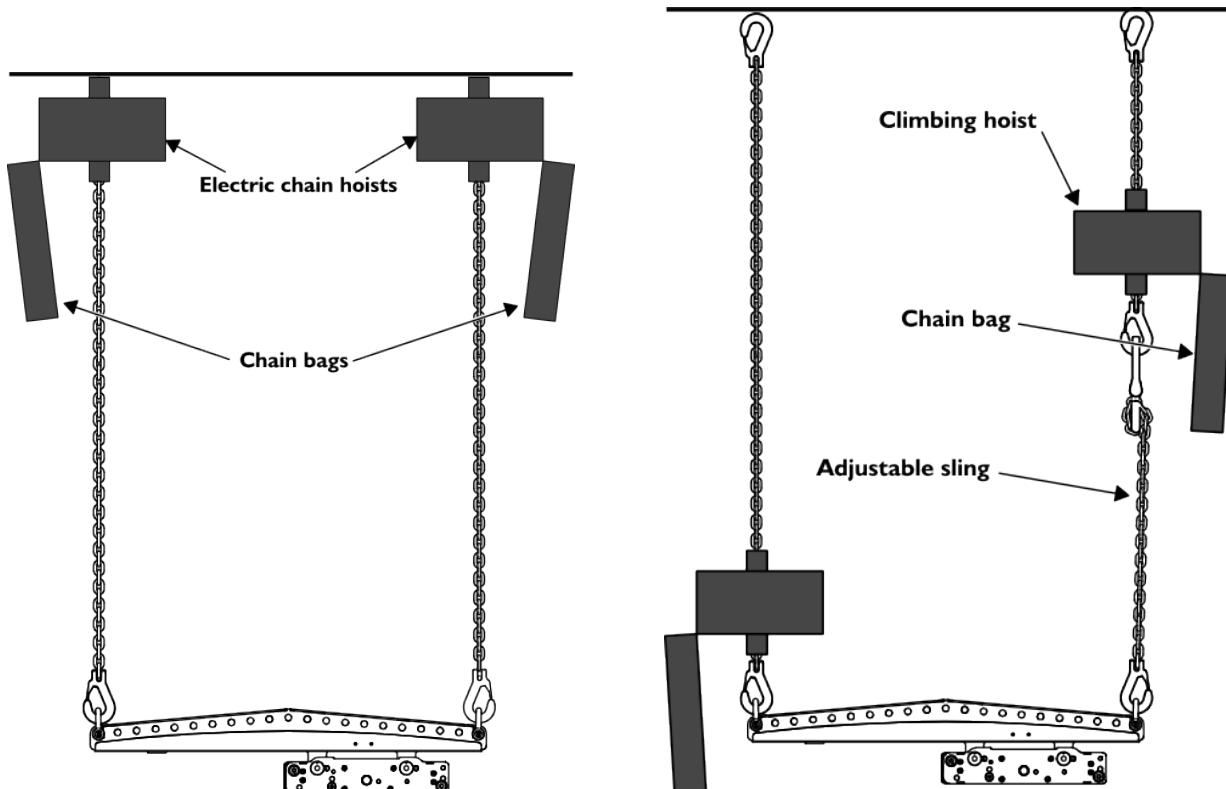

Installing a laser inclinometer

The K2 rigging system is compatible with the following laser inclinometers:

- TEQSAS®
- LAP-TEQ PLUS (part of the L-ACOUSTICS® TECH TOOLCASE)
- TEQSAS® LAP-TEQ (legacy model)
- KSG® RECLINE Compact
- SSE® ProSight

! **LAP-TEQ / LAP-TEQ PLUS sensor and display compatibility**
 The legacy LAP-TEQ sensors are compatible with the new TEQSAS® LAP-TEQ PLUS displays. Conversely, the new sensors are not compatible with the legacy displays.

TEQSAS® LAP-TEQ PLUS / LAP-TEQ / KSG® RECLINE Compact

Procedure

1. Remove the four M4 Torx screws (T20) from the plate.
2. Put thread-locker in the four threaded inserts.
3. Position the sensor so it points toward the front of the K2-BUMP.
4. Secure the sensor with the four screws.
5. Connect the XLR cable to the sensor.
6. Follow the manufacturer instructions to calibrate the inclinometer.

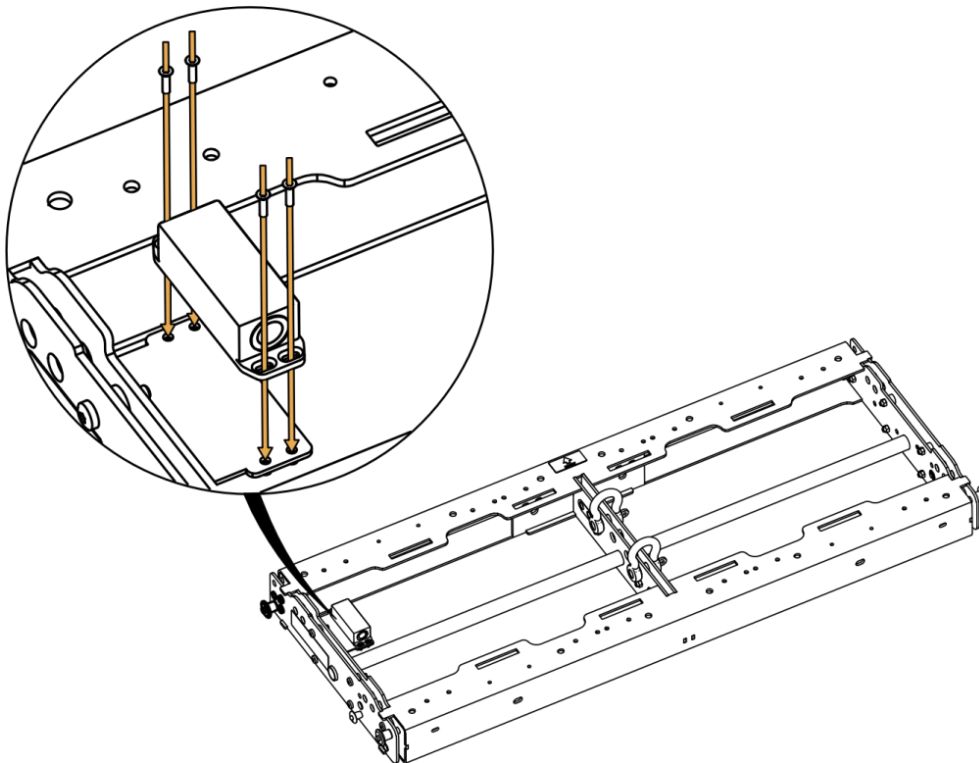

SSE PROSIGHT

Procedure

1. Install the SSE PROSIGHT laser in the SSE K2 BUMP bracket.

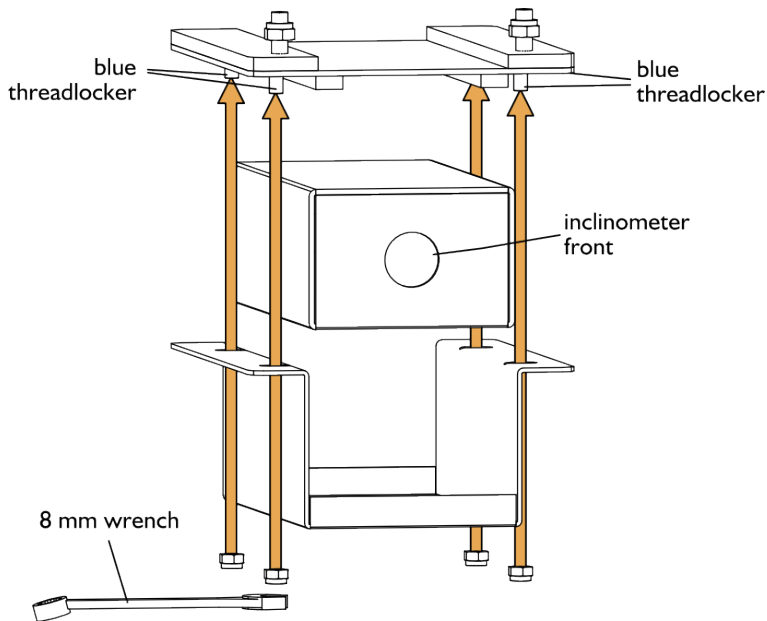

2. Remove the nuts from the top studs.

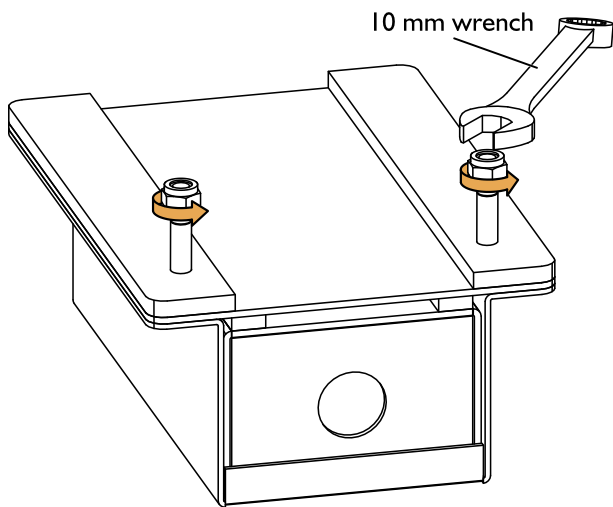

3. Position the assembly inside the K2-BUMP.

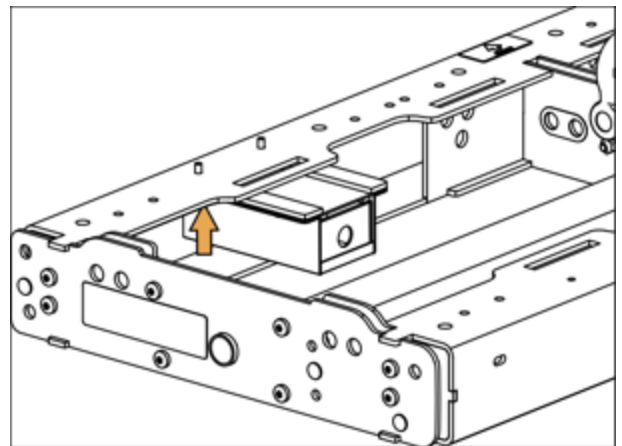
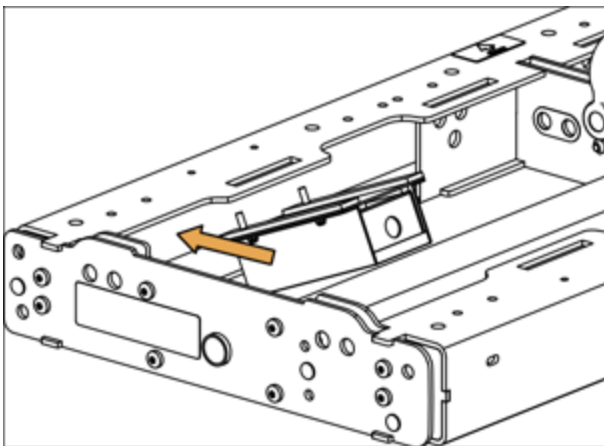

4. Secure the assembly with the two nuts.

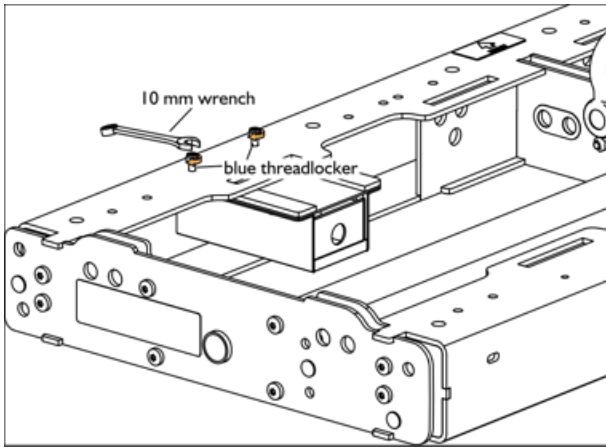

K2-LASERMOUNT

The L-ACOUSTICS® K2-LASERMOUNT is a support plate designed to attach a remote laser inclinometer to the side of a K2 enclosure. It is compatible with five sensor models: TEQSAS® LAP-TEQ PLUS (part of the L-ACOUSTICS® TECH TOOLCASE, refer to spec sheet), TEQSAS® LAP-TEQ (legacy model), KSG® RECLINE Compact, ALIGNARRAY® UVM, and SSE® ProSight.

Procedure

1. Mount the inclinometer on the K2-LASERMOUNT.

Refer to the figure below for the position of the screws on the support plate for each model.

Use thread-locker on each screw.

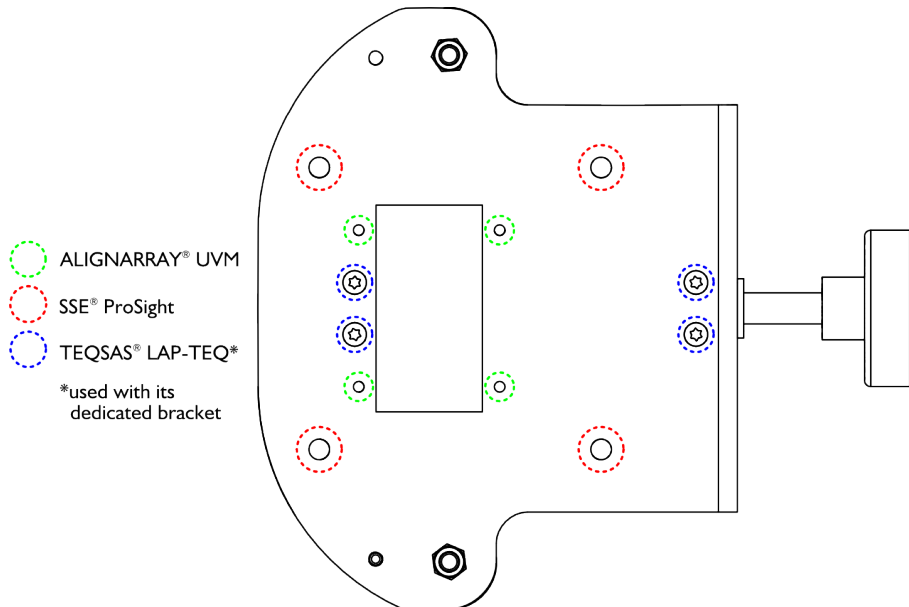

To mount the LAP-TEQ PLUS / LAP-TEQ / RECLINE use the bracket delivered with the inclinometer.

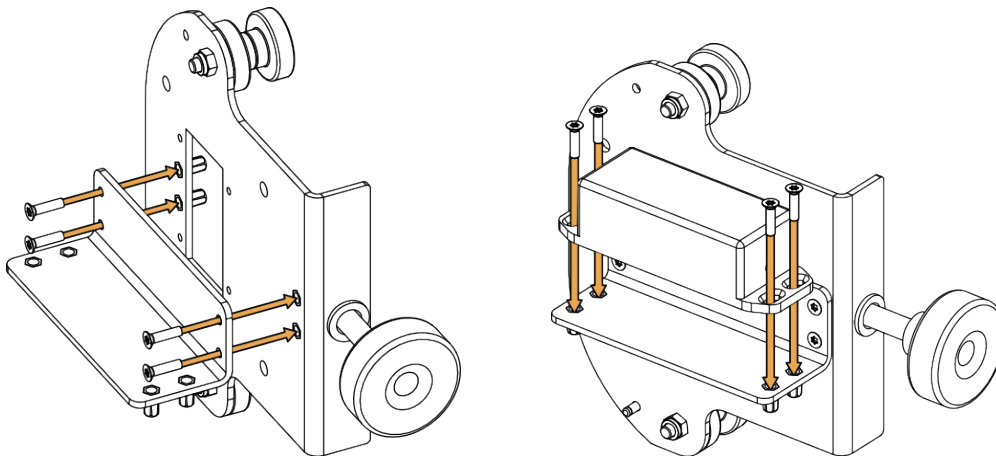

2. Rotate the front arm and secure it with its pin.

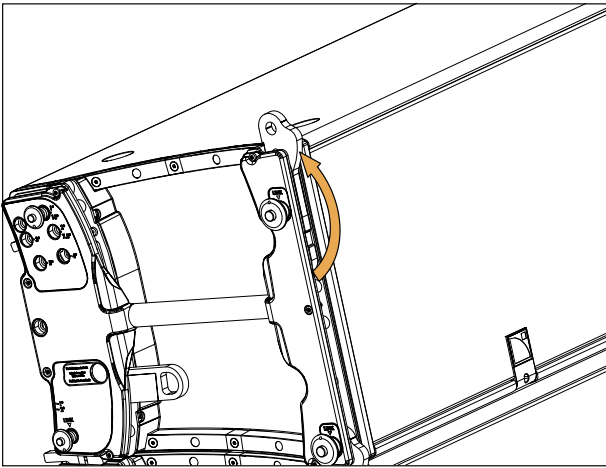

3. Position the K2-LASERMOUNT on the side of the enclosure.

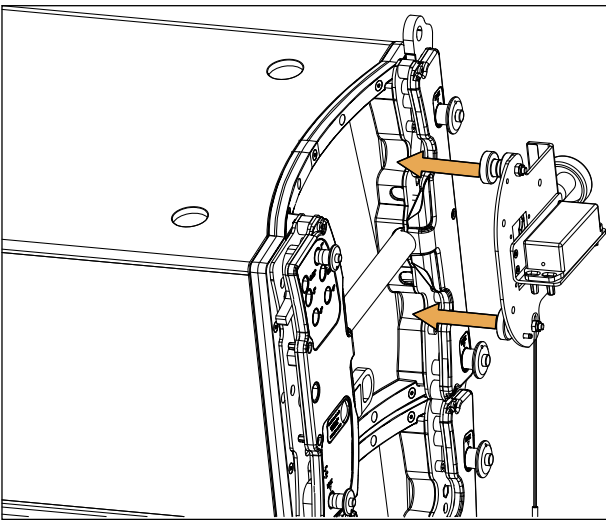

4. Maintain the K2-LASERMOUNT in position by tightening the knob.

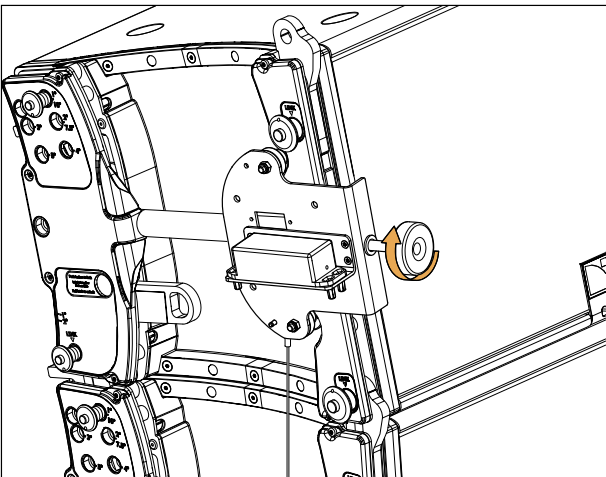

5. Secure the K2-LASERMOUNT by running the sling inside and around the K2 handle and locking it on itself.

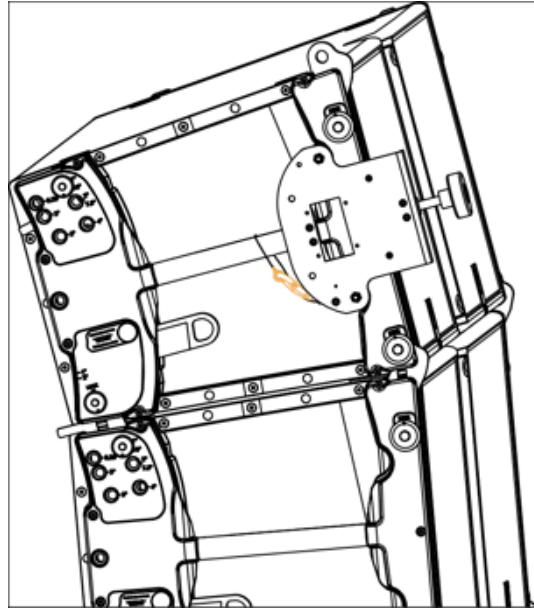
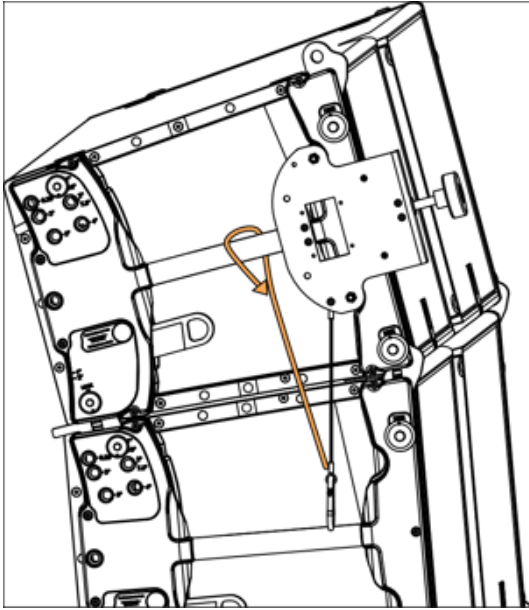

Recommendation for speaker cables

Follow the recommended maximum length for loudspeaker cables to ensure minimal SPL attenuation.



Cable quality and resistance

Only use high-quality fully insulated speaker cables made of stranded copper wire.

Use cables with a gauge offering low resistance per unit length and keep the cables as short as possible.

The table below provides the recommended maximum length for loudspeaker cables depending on the cable gauge and on the impedance load connected to the amplifier.

cable gauge			recommended maximum length					
			8 Ω load		4 Ω load		2.7 Ω load	
mm ²	SWG	AWG	m	ft	m	ft	m	ft
2.5	15	13	30	100	15	50	10	33
4	13	11	50	160	25	80	17	53
6	11	9	74	240	37	120	25	80

Use the more detailed L-Acoustics calculation tool to evaluate cable length and gauge based on the type and number of enclosures connected. The calculation tool is available on our website:

<https://www.l-acoustics.com/en/installation/tools/>



L-Acoustics

13 rue Levacher Cintrat - 91460 Marcoussis - France
+33 1 69 63 69 63 - info@l-acoustics.com
www.l-acoustics.com



 **L-ACOUSTICS**
GROUP