



MXA925

Ceiling Array Microphone

MXA925 ceiling array microphone manual. Learn how to install, use AI-enabled IntelliMix DSP for natural speech and echo cancellation, and adjust coverage

Version: 0.2 (2026-E)

Table of Contents

MXA925 Ceiling Array Microphone	4	VESA Standardized Mounting	27
MXA925 Overview	4	Suspend from the Ceiling	27
Common Questions	4	Install on a Ceiling with the A900-CM	27
Getting Started	4	Hard Ceiling Mounting	28
What Software Do I Need to Set Up This Microphone?	4	Adjust Levels	28
How to Set Up the MXA925	5	Parametric Equalizer	30
How to Turn Automatic Coverage On or Off	8	EQ Contour	32
MXA925 Parts	8	Mute Points in Control Software	32
Power Over Ethernet (PoE)	10	IntelliMix DSP Settings	34
MXA925 Dante Channels	10	DSP Best Practices	35
Model Variations	10	AI Acoustic Echo Cancellation (AEC)	35
Optional Accessories and Replacement Parts	11	Noise Reduction	36
RJ45 Network Ports	11	Automatic Gain Control (AGC)	36
What is the Bimodal Switch Configuration Setting?	12	Delay	37
What's in the Box	13	Compressor	37
Reset Button	13	AI Deverb	37
Reset Modes	14	AI Denoiser	38
MXA925 Control Software	14	Automix Channel	39
Firmware Updates	14	MXA925 Automix Settings	39
Remote Monitoring and Management in ShureCloud	15	Remove Unwanted Sounds with the Virtual Acoustic Boundary	41
Microphone Coverage	15	Speech Gating Threshold	42
Add Coverage Areas	17	Automix Modes	43
Coverage Tips	19	Mute Sync	44
Use Steerable Lobes	20	Use Presets	45
Microphone Placement Best Practices	22	Security	46
How to Install the MXA925	23	Encryption	46
Install in a Ceiling Grid	23	Set Up the 802.1X Protocol for a Device	46
		Networking	49
		Networking Best Practices	49

Switch and Cable Recommendations for Dante Network- ing	49	Use Command Strings	61
Setting Latency	50	Integrate with Camera Control Systems	61
QoS (Quality of Service) Settings	50	Troubleshooting	62
Ports, Protocols, and Firewall Rules	51	Additional Resources	63
Digital Audio Networking	51	MXA925 Specifications	64
AES67	52	MXA925 Frequency Response	65
How to Paint the MXA925	52	Dimensions	66
Paint Square Array Microphones	53	Important Safety Instructions	67
Paint MXA925-R Microphones	54	Additional Safety Warnings on Mounting	68
Monitor and Control with External Systems	60	Important Product Regulatory Information	68
Use the REST API	60		

MXA925

Ceiling Array Microphone

MXA925 Overview

The MXA925 Ceiling Array Microphone delivers top-tier audio capture for conferencing and sound reinforcement, featuring advanced AI-enabled onboard IntelliMix[®] DSP for natural speech and echo cancellation. With dual RJ45 network connectivity, ShureCloud remote management, and certifications for Microsoft Teams and Zoom Rooms, it ensures flexible, seamless integration and enterprise-ready performance for any collaboration space.

Common Questions

- [How MXA925 coverage works](#)
- [How to turn automatic coverage on or off](#)
- [Where to place the MXA925 in a room](#)
- [How to install the MXA925](#)
- [Details about IntelliMix DSP settings](#)
- [Troubleshooting common issues](#)
- [MXA925 command strings](#) for third-party control systems and camera tracking
- [AI in Our Audio and Video Products whitepaper](#)

Getting Started

What Software Do I Need to Set Up This Microphone?

Install this software on a computer that connects to the same network as the microphone:

- Control software to adjust microphone settings. This microphone has 2 options:

Option 1: [Shure Designer](#)

- Use for managing lots of Shure devices in 1 place
- Control Shure devices and route audio between them
- Create rooms to manage devices and design coverage

Option 2: Web application (open using [Shure Update Utility](#))

- Use to manage each Shure device separately
- Control each device individually with the browser-based web application
- Route audio using [Dante Controller](#)
- **Dante Controller** to send audio signals to other Dante devices. Not necessary if you're only routing audio to Shure devices in Designer.
- **Shure Update Utility** to update firmware on Shure devices and open device web applications (download at shure.com/suu)

You can also use [ShureCloud](#) for remote, real-time device monitoring and firmware updates. ShureCloud runs in the browser and does not require any software installation.

How to Set Up the MXA925

This example shows how to set up a room with an MXA925, a P300 audio conferencing processor, and 2 MXN-6 loudspeakers. The process is similar when using other combinations of devices, so use these steps as a starting point.

After completing this basic setup process, you should be able to:

- Access MXA925 control software
- Add coverage areas
- Adjust DSP settings and route audio

This example uses:

- Cat5e (or better) Ethernet cable (shielded cable recommended)
- [Network switch](#) that provides Power over Ethernet (PoE) and PoE+
- Computer with [Shure Designer](#) or [Shure Update Utility](#) software
- Compute device with videoconferencing software
- [P300 audio conferencing processor](#)
- 2 [MXN-6 loudspeakers](#)

Step 1: Install and Connect

The MXA925's default setting is a 30 x 30-foot dynamic coverage area (9 x 9 meters). For more details about mic placement and coverage, see [Microphone Coverage](#).

1. [Install the MXA925](#) and other devices. Connect devices to the switch with Ethernet cable:
 - Connect the MXA925's port 1 to PoE
 - Connect the MXN-6s to PoE or PoE+
 - Connect the P300 to PoE+

Note: See [RJ45 Network Ports](#) to learn more about available port traffic settings.

2. Connect the compute device with videoconferencing software to the P300 using USB cable.
3. Connect your computer running Designer or Shure Update Utility to the same network as the devices.
4. Open your preferred control software:
 - **Designer:** Controls all Shure Microflex[®] Ecosystem devices. Create and manage rooms, routing, and coverage.
 - **Browser-based web application:** Controls 1 device at a time (no routing). Open for each Shure device using Shure Update Utility, and route audio with Dante Controller.

Check that you're connected to the correct network to discover devices.

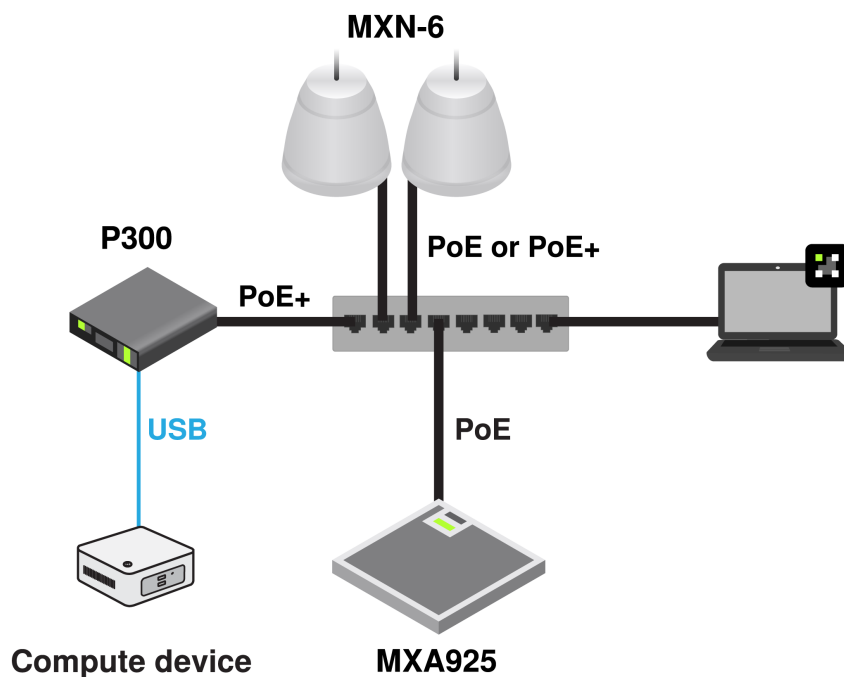

Step 2: Route Audio and Apply DSP

Route audio with Designer or Dante Controller.

Tip: For either method, always route an AEC reference signal to the MXA925's AEC reference input (even if you aren't using the mic's AEC processing). The reference signal helps improve mic coverage.

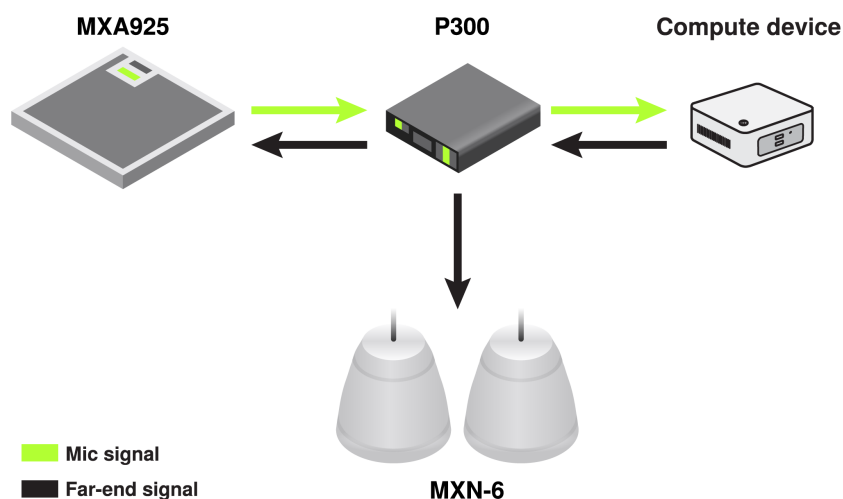

Designer: Use the auto route feature. This feature routes audio, applies DSP, turns on mute synchronization, and enables LED control for connected devices. To auto route:

1. Put all devices in the same online room. Select Auto route. Designer makes the following routes:
 - MXA925 automix output to P300
 - P300 USB input/output to compute device with videoconferencing software
 - P300 Dante output to MXA925 AEC reference input and MXN-6 loudspeakers

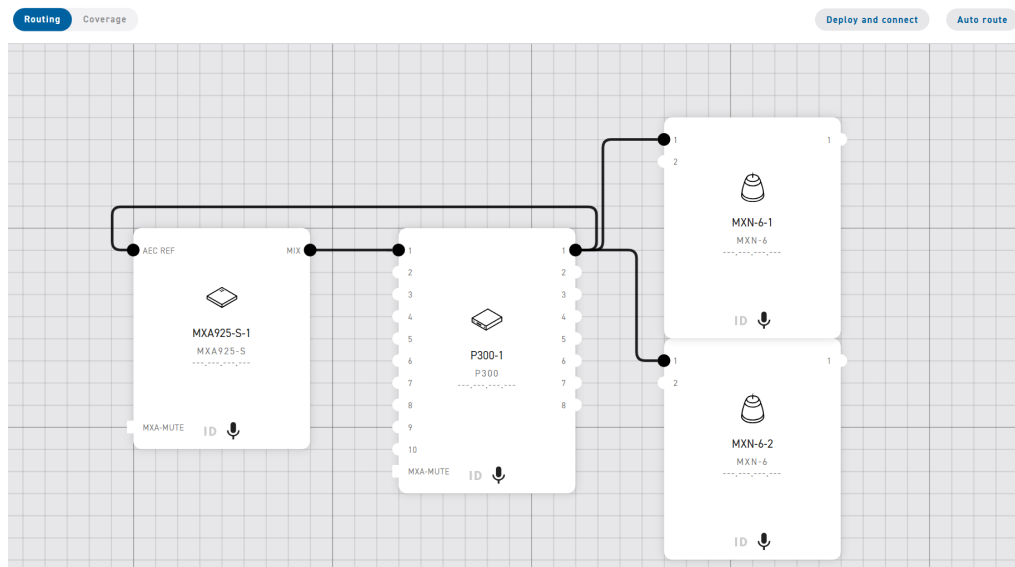

Routing view of MXA925, P300, and MXN-6s in Designer

2. Check the audio routes, matrix mixer routes, and other settings to make sure they fit your needs. You might need to:
 - Delete unnecessary routes.
 - Verify that AEC reference signals are correctly routed.
 - Fine-tune DSP blocks as needed.
 - Check P300 matrix mixer routes.

Tip: Use 1 device in your signal chain for DSP. For example, if a mic is handling noise reduction, don't use noise reduction on a downstream processor too. Learn more about [IntelliMix DSP settings](#).

Web application: Route audio using Dante Controller. For detailed instructions, see [Dante's documentation](#).

Step 3: Listen and Adjust Coverage

Make a test call and have the far-end talker tell you how the MXA925 sounds:

1. Open the videoconferencing software on the compute device connected to the P300. In the settings, choose the P300 as the speaker and microphone.
2. Place a test call with the entire system. Use Designer or the web application to make gain, EQ, or DSP adjustments in the MXA925's IntelliMix tab.

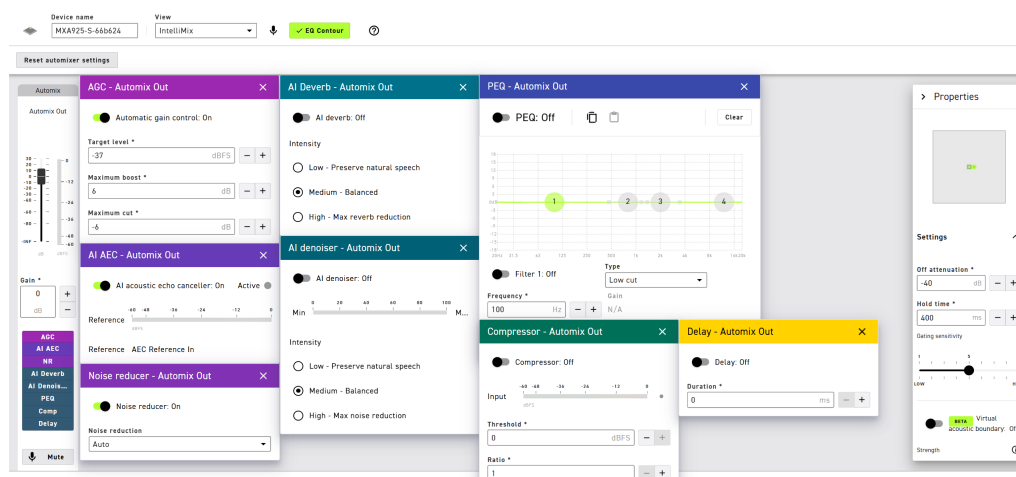

MXA925 IntelliMix DSP controls in Designer

3. To adjust mic coverage, go to Coverage. Click and drag to move the coverage area and resize as needed.
4. Use the Add coverage button to add dynamic or dedicated coverage areas. You can add any combination of up to 8 coverage areas per microphone.
 - **Designer:** Properties > Coverage > Add coverage
 - **Web application:** Coverage > Add coverage

You can also turn off automatic coverage in the device Settings menu to manually position up to 8 lobes. See [Use Steerable Lobes](#) for details.

How to Turn Automatic Coverage On or Off

The mic's automatic coverage setting determines if you use coverage areas or lobes to set up microphone coverage. By default, automatic coverage is on.

To turn automatic coverage on or off, go to:

- **Designer:**
 - [Your room] > Coverage > Select MXA925 > Properties > Coverage
 - [Your room] > Open MXA925 > Settings
- **Web application:**
 - Coverage > Select MXA925 > Properties > Coverage
 - Settings

Learn more about the automatic coverage setting in [Microphone Coverage](#).

MXA925 Parts

MXA925-S

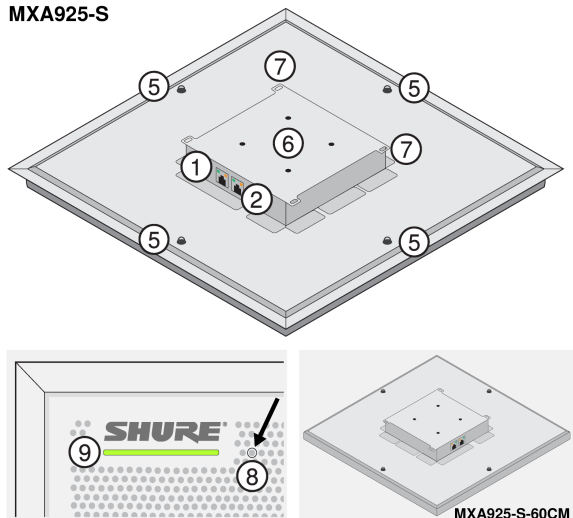

MXA925-R

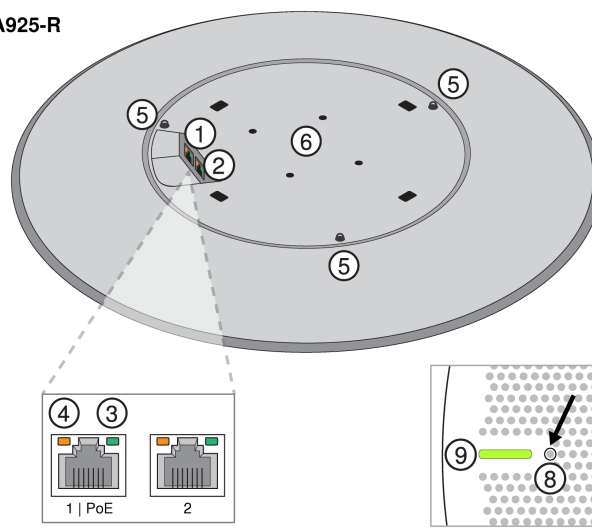

1. Primary RJ-45 network port for PoE
2. Secondary RJ-45 network port (no PoE)
3. Network status LED (green)
 - Off = No network link
 - On = Network link established
 - Flashing = Network link active
4. Network speed LED (amber)
 - Off = 10/100 Mbps
 - On = 1 Gbps
5. Eyelet screws for suspension mounting (12 mm diameter)
6. VESA MIS-D mounting holes (100 mm square)
7. Safety tether attachment points
8. Reset button
9. Mute status LED

Customize LED color and behavior in the control software: Settings > Lights.

MXA925 LED Default Settings

Microphone Status	LED Color/Behavior
Active	Green (solid)
Muted	Red (solid)
Hardware identification	Green (flashing)
Firmware update in progress	Green (progresses along bar)
Reset	Network reset: Red (progresses along bar) Factory reset: Triggers device power-up
Error	Red (split, alternate flashing)

Microphone Status	LED Color/Behavior
Device power-up	Blue (moves quickly back and forth across bar)

Note: If LEDs are off, they will still turn on when the device powers up or when an error state occurs.

Power Over Ethernet (PoE)

This device requires PoE to operate. It is compatible with **Class 0** PoE sources. Connect a cable carrying PoE to the primary port.

Power over Ethernet is delivered in one of the following ways:

- A network switch that provides PoE
- A PoE injector device

Default port traffic settings:

- Port 1: Primary Shure control and Dante audio
- Port 2: Secondary Shure control

Change port traffic settings in the control software. See [RJ45 Network Ports](#) for details.

MXA925 Dante Channels

The automatic coverage setting changes the number of Dante outputs on the MXA925.

Dante Channels (Automatic Coverage On)

- 1 automix output with IntelliMix DSP for all coverage areas
- 1 AEC reference input

Note: The automix output is the only channel that sends audio with automatic coverage on. Dante Controller shows 8 transmit channels and the automix output.

Dante Channels (Automatic Coverage Off)

- Up to 8 separate Dante outputs without IntelliMix DSP (1 for each lobe)
- 1 automix output with IntelliMix DSP
- 1 AEC reference input

Model Variations

MXA925 Model Variations

SKU	Description
MXA925W-S	White square microphone
MXA925W-S-60CM	White square microphone (60 cm)
MXA925B-S	Black square microphone
MXA925B-S-60CM	Black square microphone (60 cm)
MXA925W-R	White round microphone

SKU	Description
MXA925B-R	Black round microphone

Optional Accessories and Replacement Parts

- [A900-S-GM Gripple Mount Kit, Square](#)
- [A900W-R-GM Gripple Mount Kit, Round, White Cover](#)
- [A900B-R-GM Gripple Mount Kit, Round, Black Cover](#)
- [A900-S-PM Pole Mount Kit, Square](#)
- [A900W-R-PM Pole Mount Kit, Round, White Cover](#)
- [A900B-R-PM Pole Mount Kit, Round, Black Cover](#)
- [A900-PM-3/8IN Threaded Rod Adapter Mounting Kit](#)
- [A910-JB Junction Box Accessory](#)
- [A900-CM Ceiling Mount](#)
- [A910-HCM Hard Ceiling Mount](#)
- [RPM904 frame and grille assembly for MXA920W-S-60CM or MXA910W-60CM](#)
- [RPM901W-US frame and grille assembly for MXA920W-S or MXA910W-US](#)

RJ45 Network Ports

This device has 2 RJ45 network ports to accommodate different network configurations. The primary port is the only one that carries PoE to the device.

Bimodal is the default switch configuration setting.

Note: Two Ethernet cable runs are not required to use this device, but you can use 2 if your setup calls for it.

Follow these steps to change the device's switch configuration setting:

1. If the secondary port is connected to a network, unplug the Ethernet cable before changing the switch configuration setting. This prevents a network loop that could make the network unstable.
2. On a computer connected to the same network as the device, open Designer or the device web application. Go to **Settings > IP configuration > Switch configuration**.
3. Choose a new switch configuration setting. The device will reboot to apply the change.
4. If needed, reconnect the secondary port's Ethernet cable.

Device Switch Configuration Options

Switch Configuration Setting	Primary Port (1 PoE)	Secondary Port (2)
Bimodal (default)	Primary Shure control (Designer, web application, and ShureCloud) Primary Dante audio	Secondary Shure control (ShureCloud)
Switched	Primary Shure control Primary Dante audio	Primary Shure control Primary Dante audio

Switch Configuration Setting	Primary Port (1 PoE)	Secondary Port (2)
Redundant	Primary Shure control Primary Dante audio	Secondary Dante audio
Split	Primary Shure control	Primary Dante audio

What is the Bimodal Switch Configuration Setting?

The bimodal switch configuration setting provides a new way to split up Dante audio and Shure control data on your networks. When using the bimodal setting, the 2 RJ45 ports carry the following data:

Primary Port (1 PoE)	Secondary Port (2)
Primary Shure control: Designer, web application, and ShureCloud (if connected to network with internet access) Primary Dante audio	Secondary Shure control: ShureCloud (if connected to network with internet access) and web application

The bimodal setting is designed for installations that require:

- Dante audio separated from the enterprise network
- Access to some control and monitoring information about the device on the enterprise network

Bimodal is the default switch configuration setting for this device. To change the switch configuration setting, follow the steps in [RJ45 Network Ports](#).

Bimodal Example Diagram

In this example, the primary port is connected to an isolated device network for the room. The secondary port is connected to an enterprise network with internet access for monitoring and management in ShureCloud.

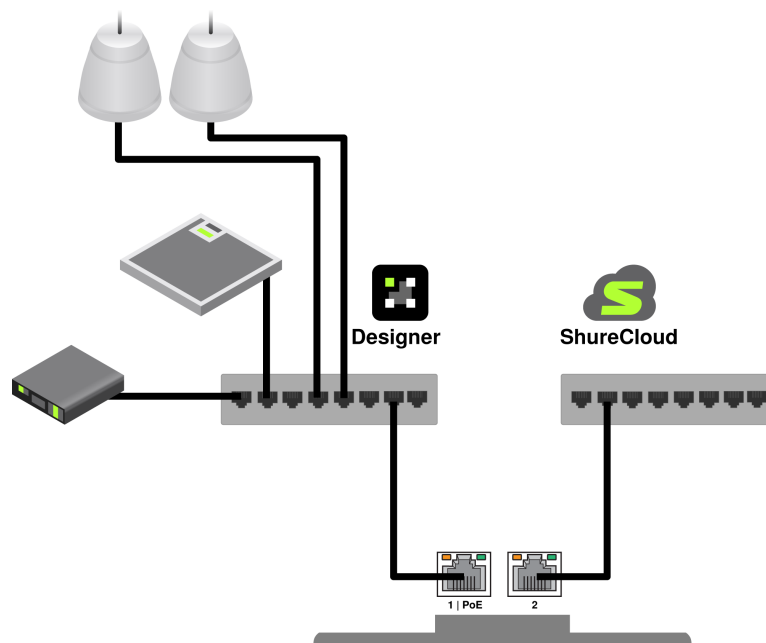

Bimodal Setting Tips

- Use the network connected to primary port 1 to discover the device in Designer or open the device's web application. The network connected to secondary port 2 won't show the device in Designer.
- If you aren't using secondary port 2, turn off the unused port in Settings > IP configuration.
- The device prioritizes a gateway with internet access on the secondary port 2 before checking primary port 1.

What's in the Box

Square or round array microphone	MXA925-S or MXA925-R
Square or round hardware kit	
Square:	
Cable ties (8)	
Strain relief tabs (3)	Square: 90A49117
Rubber pad set	Round: 90A49116
Round:	
Cable ties (8)	
Strain relief tabs (3)	

Reset Button



The reset button is behind the grille. To push it, use a paper clip or other tool.

Button locations:

- **Square array microphones:** Behind the grille hole with a silkscreened circle around it.
- **Round array microphones:** Behind the first grille hole to the right of the mute status LED.

Reset Modes

- **Network reset** (press for 4-8 seconds): Resets all Shure control and audio network IP settings to factory defaults. Red LED along bar.
- **Full factory reset** (press for more than 8 seconds): Resets all network and configuration settings to the factory defaults. LED turns off, then blue along bar.

MXA925 Control Software

There are 2 ways to control the MXA925:

- **Option 1:** Use [Shure Designer](#) software
 - Designer gives you access to all Shure Microflex Ecosystem device settings.
 - Create and manage rooms, routing, and coverage for Shure devices.
 - Route audio to and from Shure devices.
- **Option 2:** Open the device's browser-based web application using [Shure Update Utility](#)
 - Browser-based web application lets you control 1 microphone's settings.
 - No access to room-level information.
 - To route audio, use [Dante Controller software](#).

For Designer or the web application, use the primary Shure control network on port 1 to discover the device.

Use Shure Update Utility or ShureCloud to update firmware.

Firmware Updates

Firmware is embedded software in each component that controls functionality. Periodically, new versions of firmware are developed to incorporate additional features and enhancements. You can update firmware using Shure Update Utility or ShureCloud.

Download Shure Update Utility at shure.com/suu.

For release notes and more details about releases, visit the [Software and Firmware Archive](#).

Remote Monitoring and Management in ShureCloud

Use [ShureCloud](#) to remotely view information about supported devices.

Refer to the ShureCloud user guide to learn [how to add devices to your ShureCloud account](#).

Microphone Coverage

The MXA925 has 2 main mic coverage settings: automatic coverage on and automatic coverage off.

The default setting is automatic coverage on with a 30 x 30-foot dynamic coverage area (9 x 9 meters).

Automatic Coverage On

- Create up to 8 larger square or rectangular coverage areas. Choose from dynamic or dedicated coverage areas.
- Mic captures all talkers inside coverage area boundaries, even if they move
- 1 automix output with IntelliMix DSP

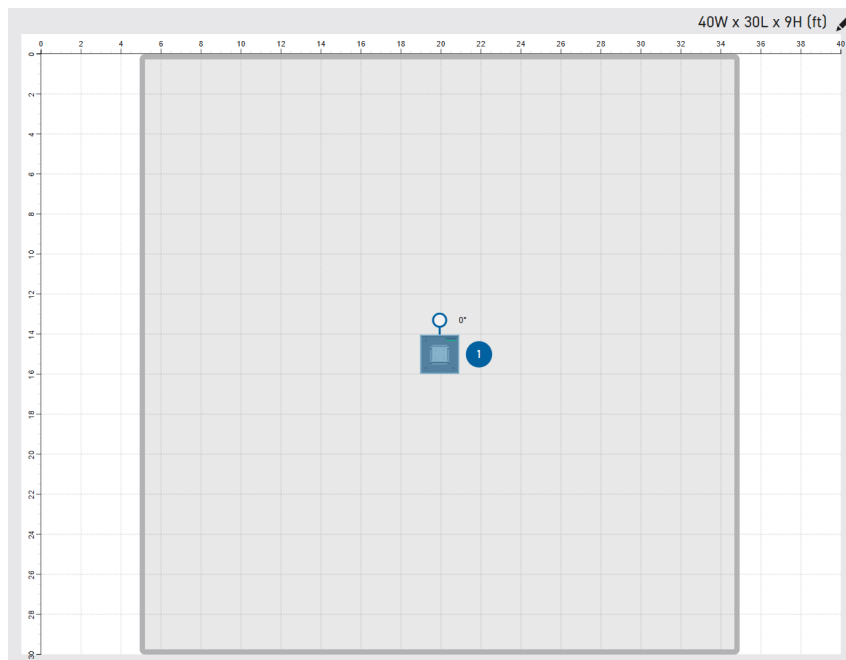

Automatic Coverage Off

- Move up to 8 steerable lobes with direct outputs (required for voice lift applications)
- Mic captures all talkers inside lobe boundaries, similar to legacy MXA910
- 8 direct outputs and 1 automix output with IntelliMix DSP

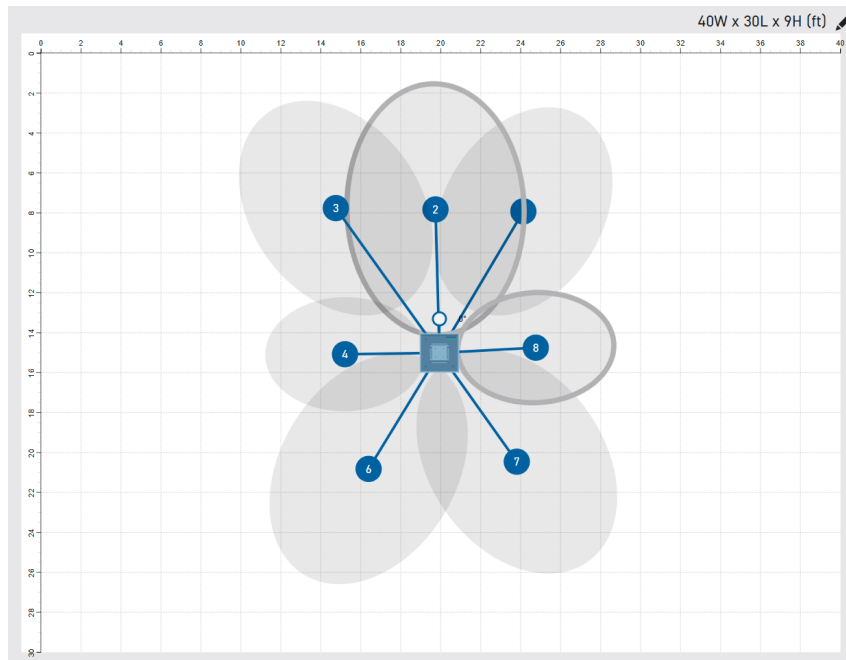

To turn automatic coverage on or off:

- **Designer:**
 - [Your room] > Coverage > Select MXA925 > Properties > Coverage
 - [Your room] > MXA925 > Settings > Automatic coverage
- **Web application:**
 - Coverage > Select MXA925 > Properties > Coverage
 - Settings

To place mic coverage:

- **Designer:** Add the microphone to a design or online room and go to Coverage.
- **Web application:** Coverage.

How Much Space Does the MXA925 Cover?

For most rooms, Shure recommends:

- Distance from talker to microphone: Up to 16 feet (4.9 meters)
- Mounting height: Up to 12 feet (3.7 meters)

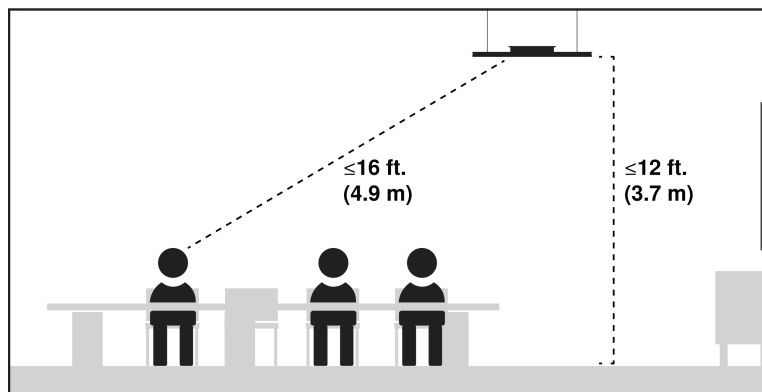

These numbers depend on your room's acoustics, construction, and materials.

In rooms with well-controlled acoustics, you can mount the MXA925 higher than 12 feet and achieve great results. Refer to [Microphone Placement Best Practices](#) for details.

Tip: After installation, enter the device's mounting height in the control software to help improve beamforming coverage: Coverage > Properties > Position.

Add Coverage Areas

Automatic coverage = On

The default coverage area is a 30 x 30-foot dynamic coverage area (9 x 9 meters). Any talker inside has coverage, even if they stand up or walk around.

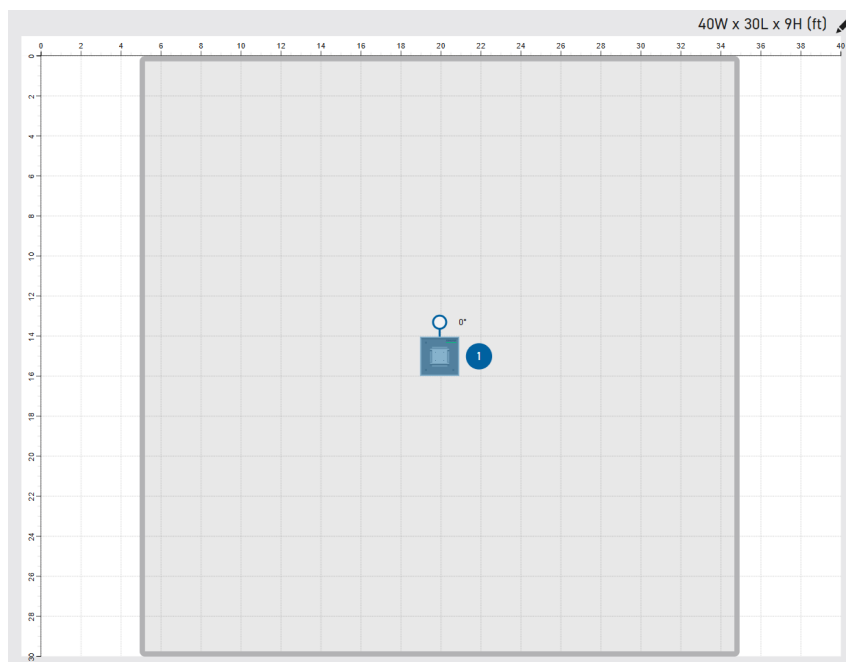

MXA925 default coverage area

To add coverage areas, go to the Coverage view, select the MXA925, and go to Properties > Coverage > Add coverage. Add up to 8 coverage areas per microphone and mix both types as needed. Drag and drop to move coverage areas.

Dynamic Coverage Areas

Dynamic coverage areas have flexible coverage. The microphone intelligently adapts to cover all talkers in the coverage area. Change the size to fit your space, and any talker within the boundaries of the coverage area will have microphone coverage (even as they move).

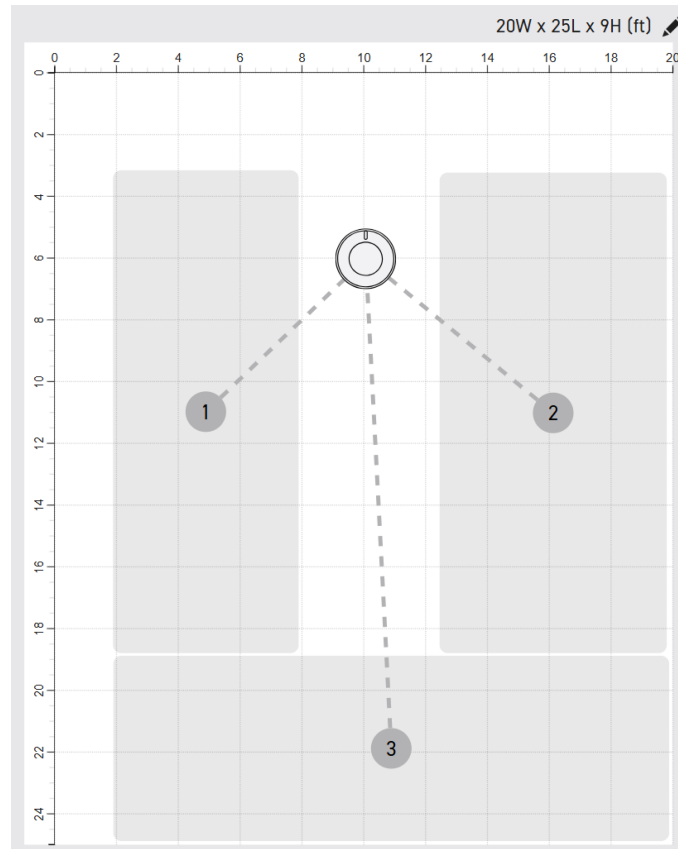

MXA925-R with 3 dynamic coverage areas

Dedicated Coverage Areas

Dedicated coverage areas (yellow border) always have microphone coverage, which means that a lobe never leaves this area. They have a set size of 6 x 6 feet (1.8 x 1.8 meters). Dedicated coverage works best for talkers that are in one position most of the time, like at a podium or a whiteboard.

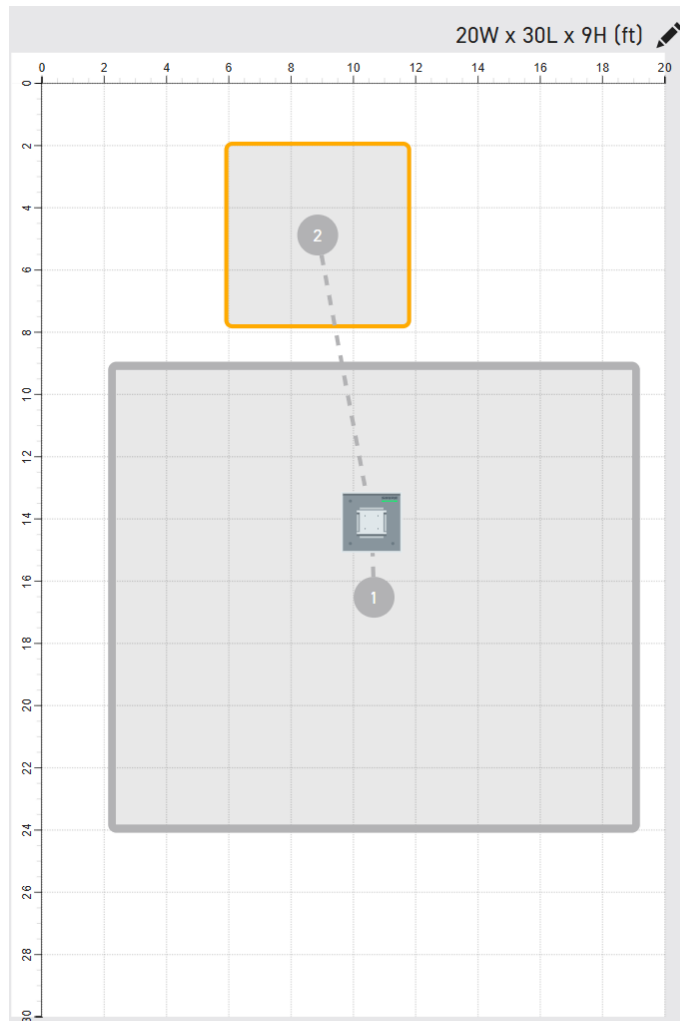

MXA925-S with 1 dedicated coverage area and 1 dynamic coverage area

Coverage Tips

Follow these best practices as you place mic coverage for MXA925s:

- Move the coverage areas or lobes to match where people will talk.
- Rotate the MXA925 in Designer to match your installation. Use the mic LED as a reference point.

Note: In the Coverage view, MXA925-R mics show the LED at the 12 o'clock position by default, which is a change compared to MXA920-R mics.

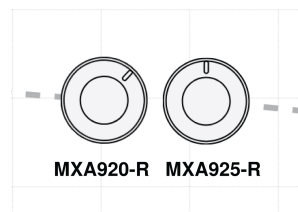

- After installation, enter the device's mounting height in the control software to help improve beamforming coverage: Coverage > Properties > Position.

Tips for Rooms with Multiple MXA925s

- Use Designer so that you can see the coverage area for each microphone on the same coverage map.
- Set up coverage areas or lobes so that they don't overlap.
- Route microphone signals to a processor with an automixer. The automixer mixes the signals from each MXA925 based on who is talking.
 - Shure options: P300 or a PC with IntelliMix Room[®] software
 - The ANIUSB-MATRIX works best with 1 microphone because it doesn't have an automixer.
- Always route an AEC reference signal to each microphone (even if you aren't using the mic's AEC processing). The reference signal helps improve mic coverage.

Use Steerable Lobes

Automatic coverage = Off

To use steerable lobes, [turn off automatic coverage](#).

With automatic coverage off, you can manually position up to 8 microphone lobes. This mode is best for when you need direct outputs, like for a multi-zone voice lift system. The microphone doesn't use coverage areas when automatic coverage is off.

Each lobe has its own channel controls when automatic coverage is off.

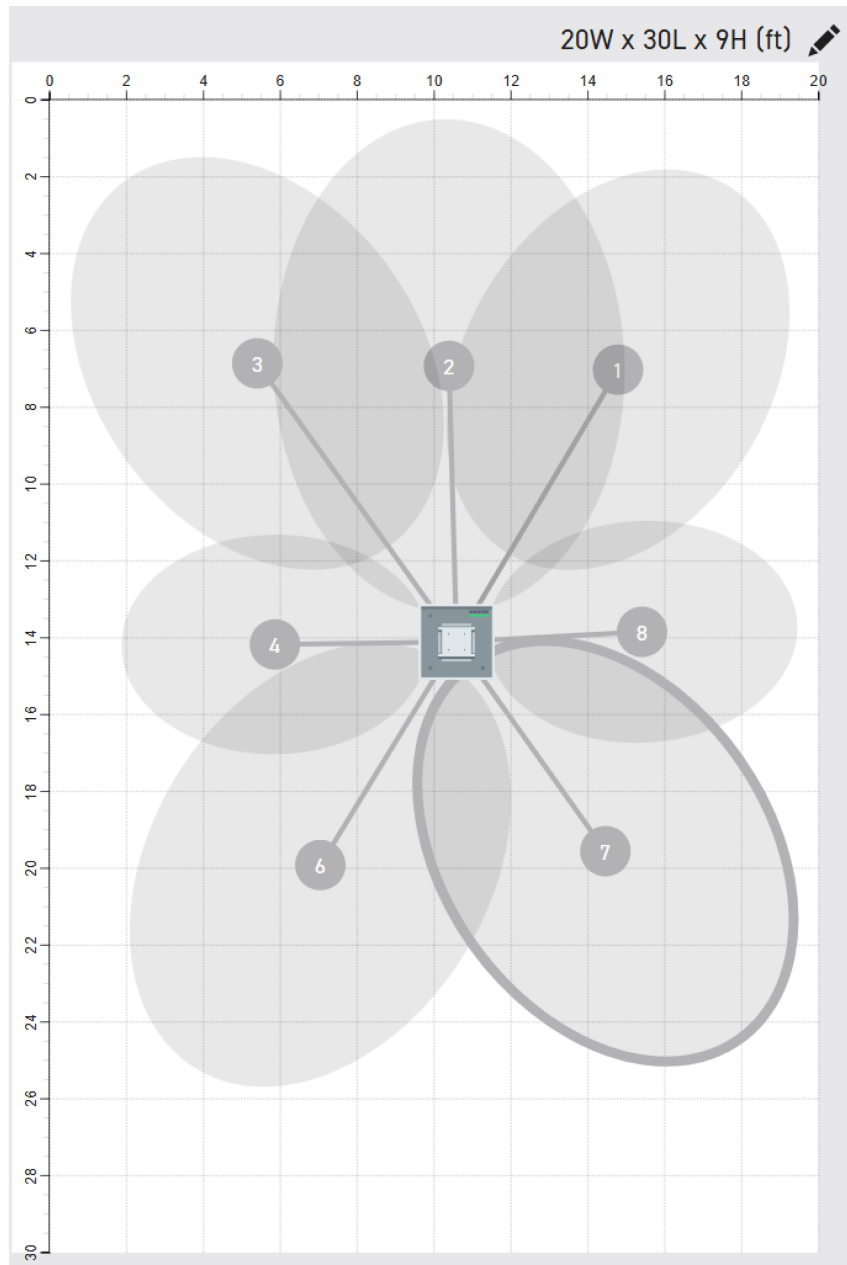

Follow these steps to position microphone lobes:

Step 1: Adjust Mic Settings

1. Open the control software and enter a device mounting height value in Coverage > Properties > Position. If needed, also adjust the room height value in Designer. You should always set the mounting height to improve beam-forming coverage.
2. Move and rotate the mic to match how it is installed in the space.

Step 2: Position Lobes and Test

1. There are 8 lobes by default. Delete lobes as needed with the delete key.

2. Click and drag to move the lobes to cover any area where someone will talk:
 - The properties panel shows precise X/Y position measurements in relation to the mic.
 - Use the grid to measure the precise placement.
3. Adjust the lobe width in Coverage > Properties > Lobe control.

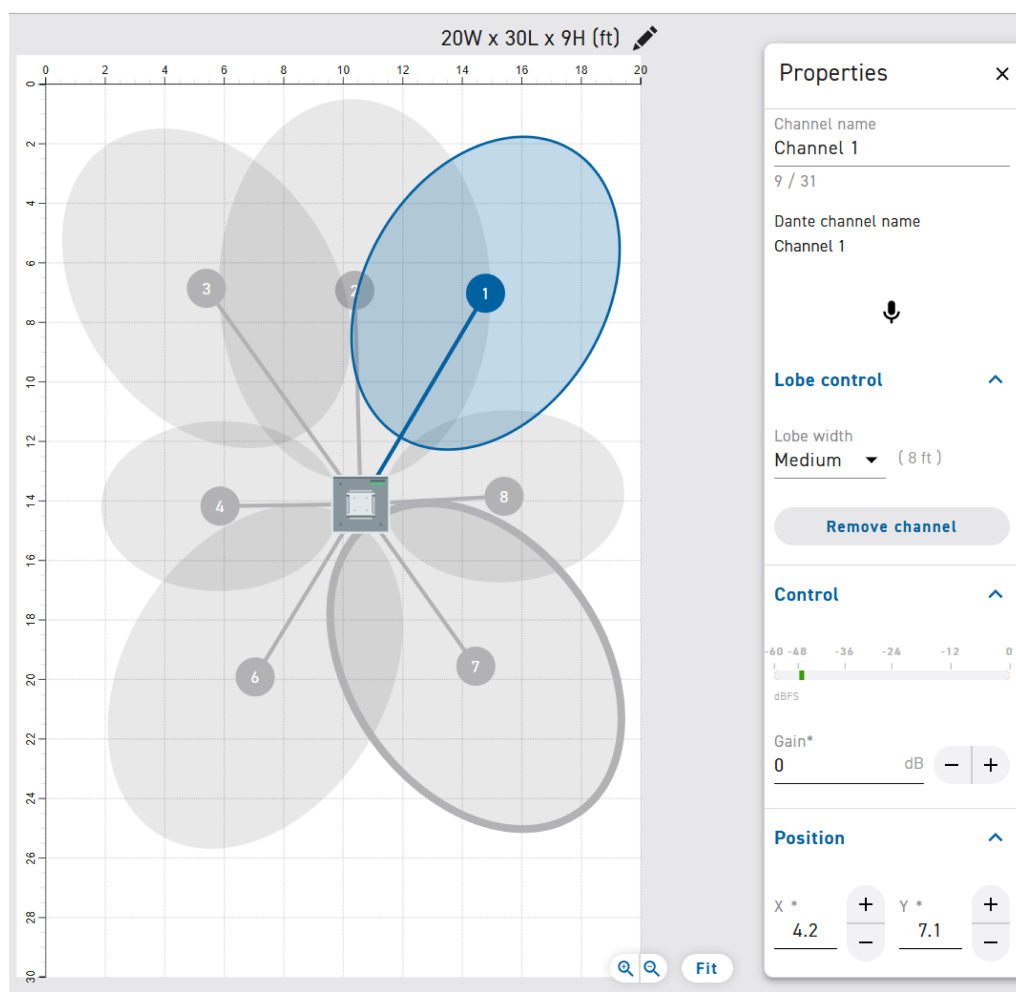

4. Make a test call with the mic and have someone in the room talk from each lobe position. Listen and adjust lobes accordingly to get the best position.

Microphone Placement Best Practices

Room Variables

Decide where to install the microphone by looking at the room's seating arrangements and infrastructure. Follow these guidelines for best results:

- Don't install the microphone behind obstructions.
- Install the microphone at least 4 feet (1.2 meters) from noise sources. These include air vents, projectors, or loudspeakers that have high dB levels.
 - Loudspeakers tend to have higher dB levels when installed above 10 feet (3 meters).
- In rooms where talkers turn to face a screen, install the microphone toward the screen so talkers naturally talk toward the microphone.

- In rooms with flexible seating arrangements or multiple microphones, use Designer to ensure that the coverage is adequate for all seating scenarios.
 - If installing multiple microphones, set up coverage areas so they don't overlap.
- Install acoustic treatment to improve speech intelligibility in rooms that are too reverberant.
- If you're planning to use [X/Y/Z coordinates for camera tracking](#), install the MXA925 so that it's level and not angled. Coordinates will not be reported accurately if the device is tilted.

Mounting Height

For most rooms, Shure recommends a mounting height of up to 12 feet (3.7 meters). In rooms with controlled acoustics, you can install the MXA925 higher than 12 feet and get great results.

Tip: After installing, enter the device's height in the control software to help improve beamforming coverage: Coverage > Properties > Position.

Consider the following when choosing a mounting height:

- The pickup pattern of the ceiling array is narrower than a shotgun microphone, so it can be placed farther from sound sources. There is no specific barrier at which the audio degrades or gates off.
- Like all microphones, tonality changes as the distance from the source increases.
- The pickup area of the microphone increases slightly as it is mounted higher.

How to Install the MXA925

There are many ways to install MXA925 microphones. Before installation, refer to the [Microphone Placement Best Practices](#) to help choose the best location for your ceiling array microphone.

Square Installation Options

- [Ceiling grid](#)
- [VESA mounting device](#)
- [NPT pole](#)
- [Suspend from ceiling with A900-GM](#)
- [Suspend from ceiling with your own hardware](#)
- [3/8-inch threaded rod](#)
- [Attach to ceiling with A900-CM](#)
- [Hard ceilings](#)

Round Installation Options

- [VESA mounting device](#)
- [NPT pole](#)
- [Suspend from ceiling with A900-GM](#)
- [Suspend from ceiling with your own hardware](#)
- [3/8-inch threaded rod](#)
- [Attach to ceiling with A900-CM](#)

Install in a Ceiling Grid

MXA925-S microphones can be installed in standard 2-foot and 60 cm ceiling tile grids.

Before you begin:

- Remove the plastic cover from the microphone.
- If using, install the rubber pads on the corners of the microphone to prevent scratches.

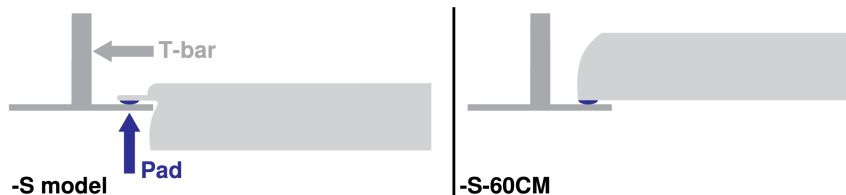

- Verify that your ceiling grid size matches your model variation.
- If using the A910-JB junction box, install it before ceiling installation.

Important: Do not install the 60 cm model in a 2-foot (609.6 mm) ceiling grid.

1. Make space in the ceiling grid for the array microphone to be installed.
2. Route all Ethernet cables above the ceiling grid and through the opening in the ceiling.
3. Connect the cable carrying PoE to the primary port 1.

Default port traffic settings:

- Port 1: Primary Shure control and Dante audio
- Port 2: Secondary Shure control

Change port traffic settings in the control software. See [RJ45 Network Ports](#) for details.

4. Attach braided metal cable or other high-strength wire (not included) between the building structure and a safety tether attachment point on the back of the microphone. This safety measure prevents the microphone from falling in an emergency situation. Make sure there is no tension on the safety tether. Follow any local regulations.
5. Install the microphone in the ceiling grid.

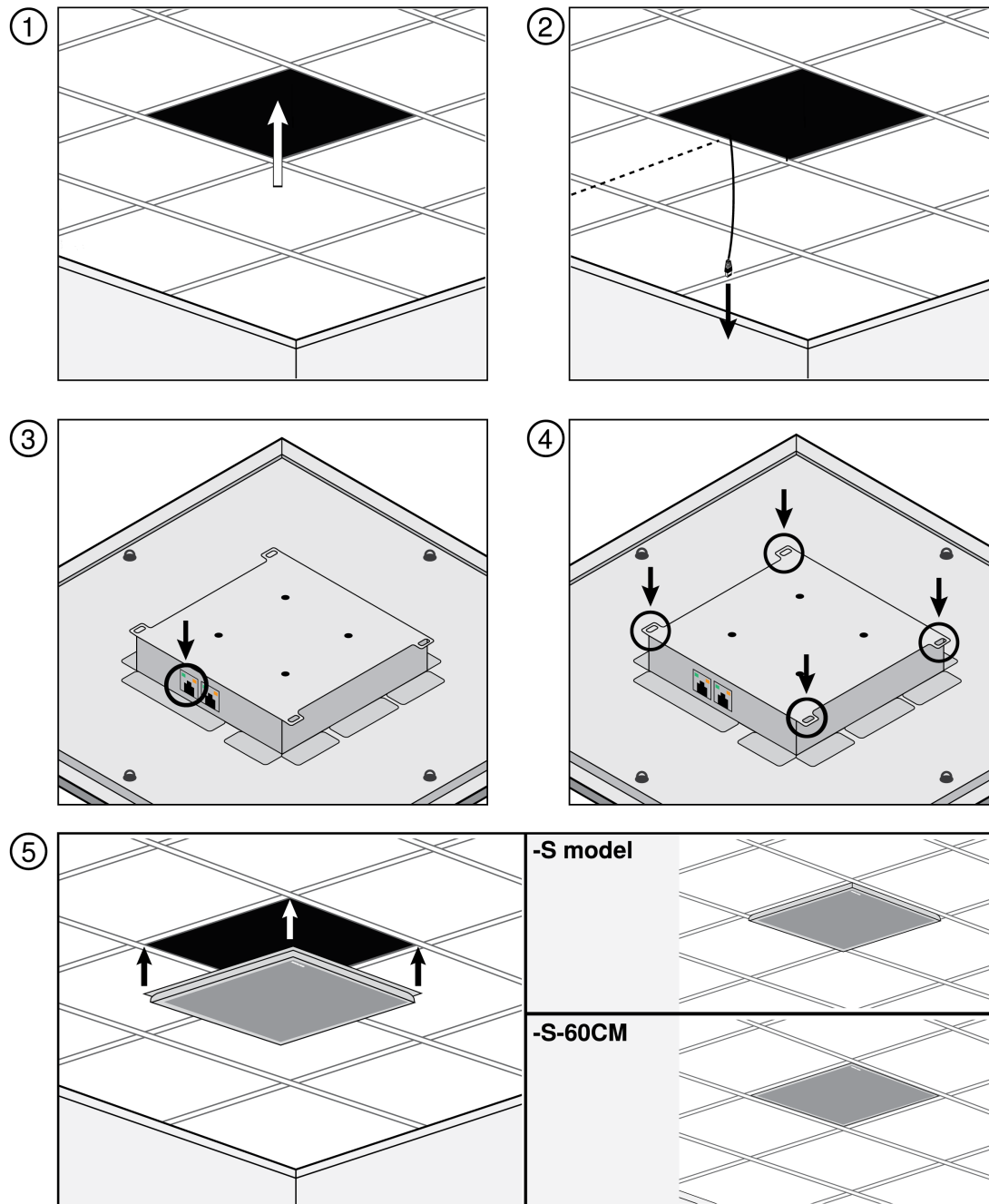

Installing the Junction Box Accessory

The A910-JB junction box mounts on square ceiling array microphones to connect conduit. There are 3 knockouts on the junction box for attaching conduit. See local regulations to determine if the junction box is necessary.

Note: Install the junction box on the microphone before installing the microphone in the ceiling.

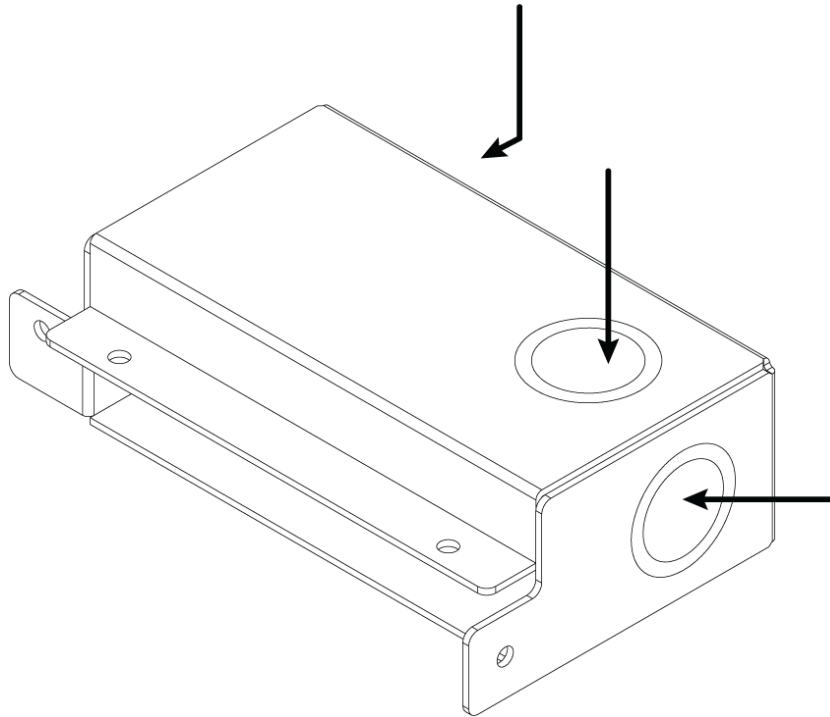
**To install:**

1. Remove the knockout you plan to use on the junction box.
2. Remove the 4 screws from the microphone as shown.

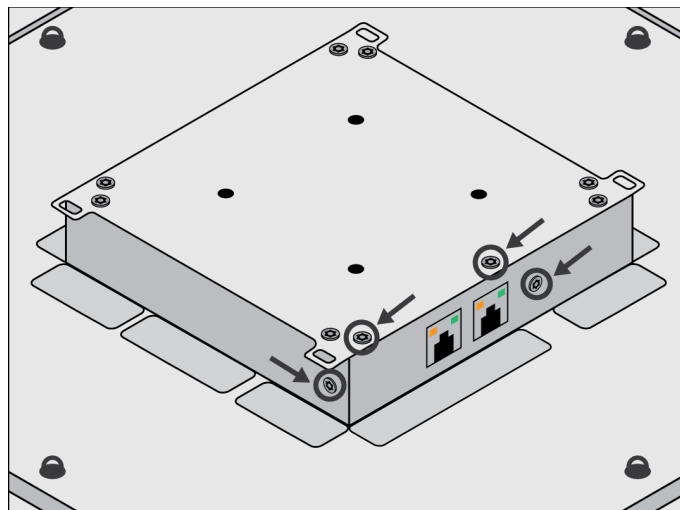

3. Align the junction box with the screw holes. If possible, plug the network cable into the microphone before securing the junction box.
4. Reinstall the 4 screws to secure the junction box to the microphone.

VESA Standardized Mounting

The rear plate has 4 threaded holes for attaching the microphone to a VESA mounting device. The mounting holes follow the VESA MIS-D standard:

- Screw specification: M4 thread (hole depth = 9.15 mm)
- Hole spacing: 100 mm square

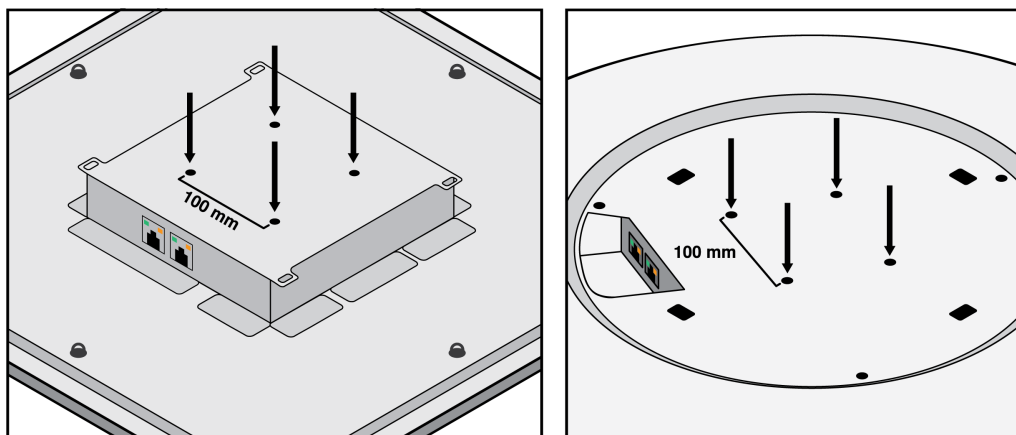

The VESA mounting holes work with Shure's [A900-PM](#) and [A900-PM-3/8IN](#) accessories to mount the microphone on a pole.

Suspend from the Ceiling

Suspend the microphone using your own equipment or with Shure's [A900-GM kit](#) (includes mounting cables and hooks).

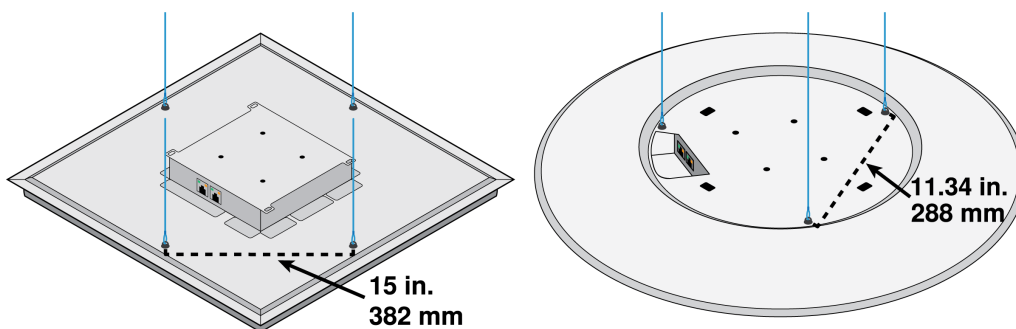

To mount using your own equipment, you will need:

- Braided metal cable or high-strength wire
 - Hardware to attach cable to ceiling
1. Attach the mounting cables to the 12 mm diameter eyelet screws on the microphone.
 2. Attach the cables to the ceiling using the appropriate hardware. Follow any local regulations.

Install on a Ceiling with the A900-CM

Attach array microphones to the ceiling with the A900-CM mounting kit.

Refer to the [A900-CM user guide](#) to learn how to install on other ceiling materials.

Hard Ceiling Mounting

You can mount square ceiling array microphones in hard ceilings without a tile grid using the A910-HCM accessory.

Learn more at www.shure.com.

Adjust Levels

Before adjusting levels, set up a way to listen to the microphone directly. A common option is to make a test call with your videoconferencing software and have the other person tell you how the mic sounds. Two other options are:

- Use a Dante® headphone amp or
- Use Dante Virtual Soundcard

To adjust levels, open the MXA925 in Designer or use the device web application. There are different gain faders available depending on if automatic coverage is on or off.

Gain Fader (Automatic Coverage On)

There is 1 gain fader with automatic coverage on. The automix gain (post-gate) changes the automix output's overall gain.

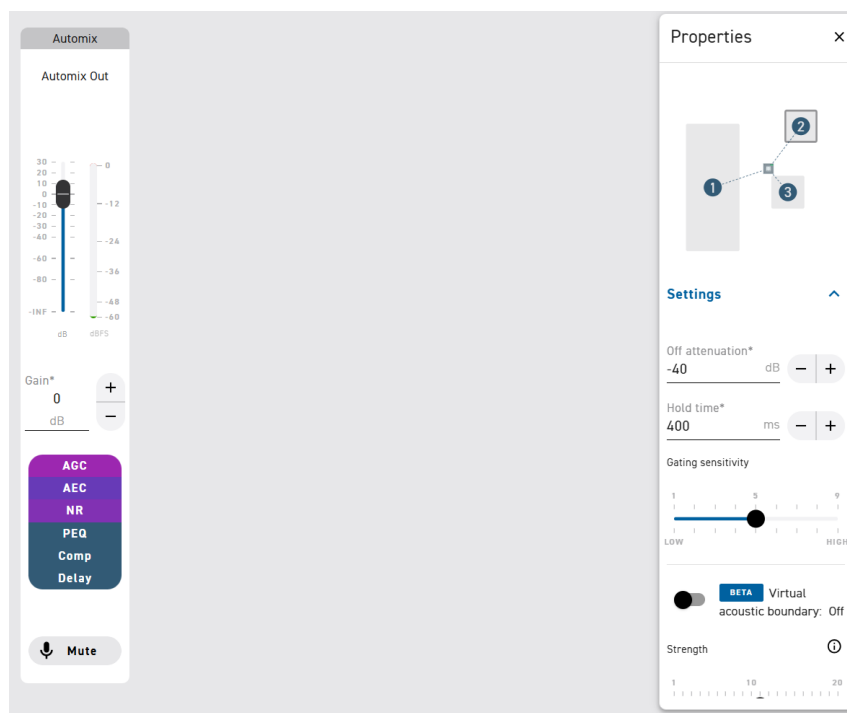

MXA925 post-gate automix gain fader

Gain Faders (Automatic Coverage Off)

There are 2 sets of gain faders with automatic coverage off:

Input gain (pre-gate): Channels view

- Affects a channel's gain before it reaches the automixer and affects the automixer's gating decision
- Boosting input gain makes the lobe more sensitive to sound sources and more likely to gate on when you use the automix output.

- Lowering input gain makes the lobe less sensitive and less likely to gate on.
- If you're only using direct outputs for each channel without the automixer, you only need to use these faders.

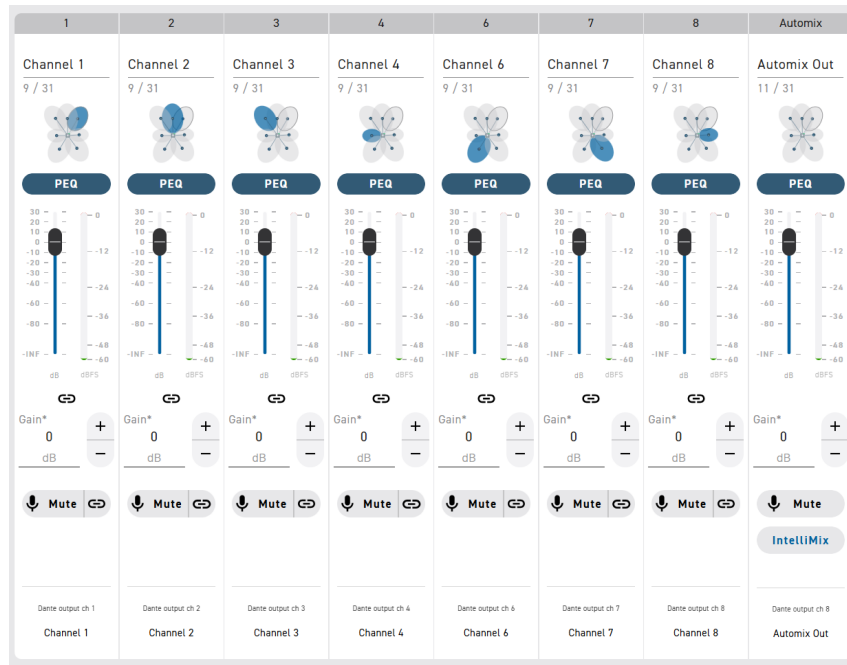

MXA925 pre-gate channel gain faders

Automix gain (post-gate): IntelliMix view

- Adjusts a channel's gain after the lobe has gated on
- Use these faders to adjust the level of each channel in the mix.
 - Does not affect the automixer's gating decision

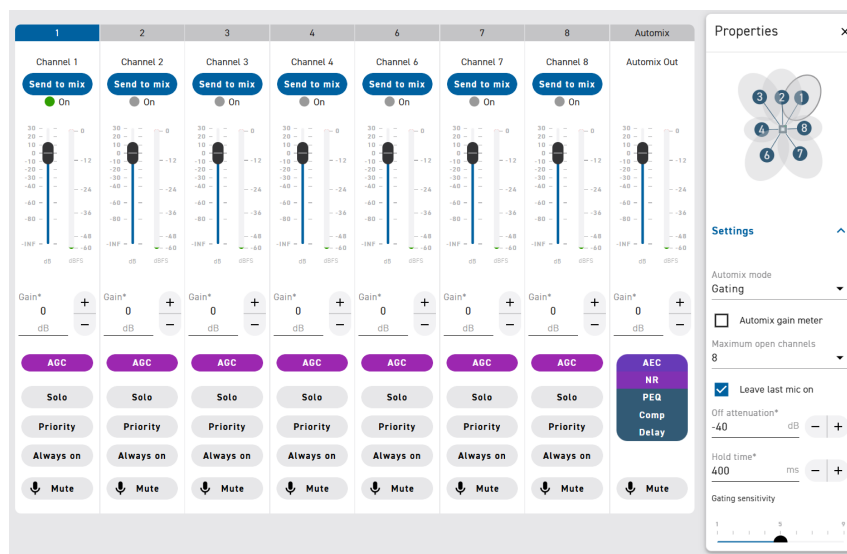

MXA925 post-gate automix gain faders

You can adjust the automix output's overall gain using the automix output fader in the Channels or IntelliMix views.

Parametric Equalizer

Maximize audio quality by adjusting the frequency response with the parametric equalizer.

Common equalizer applications:

- Improve speech intelligibility
- Reduce noise from HVAC systems or video projectors
- Reduce room irregularities
- Adjust frequency response for reinforcement systems

Setting Filter Parameters

Adjust filter settings by manipulating the icons in the frequency response graph, or by entering numeric values. Disable a filter using the checkbox next to the filter.

PEQ Filter Settings

Setting	Function
Filter Type	<p>Only the first and last band have selectable filter types.</p> <p>Parametric: Attenuates or boosts the signal within a customizable frequency range</p> <p>Low Cut: Rolls off the audio signal below the selected frequency</p> <p>Low Shelf: Attenuates or boosts the audio signal below the selected frequency</p> <p>High Cut: Rolls off the audio signal above the selected frequency</p> <p>High Shelf: Attenuates or boosts the audio signal above the selected frequency</p>
Frequency	Select the center frequency of the filter to cut or boost
Gain	Adjusts the level for a specific filter (+/- 18 dB)
Q	Adjusts the range of frequencies affected by the filter. As this value increases, the bandwidth becomes thinner.
Width	<p>Adjusts the range of frequencies affected by the filter. The value is represented in octaves.</p> <p>Note: The Q and width parameters affect the equalization curve in the same way. The only difference is the way the values are represented.</p>

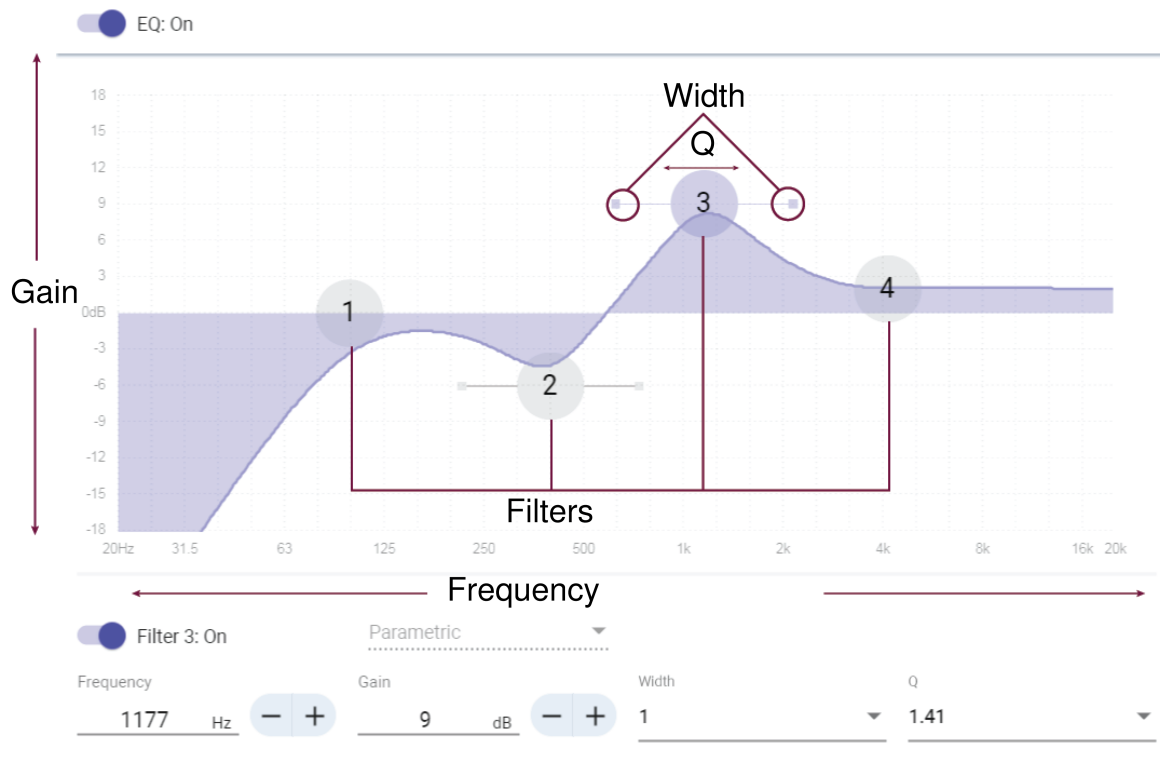

Copy and Paste Equalizer Channel Settings

Use to quickly apply the same PEQ setting across multiple channels.

1. Select the PEQ of the desired channel.
2. Click copy.
3. Select the channel to apply the PEQ setting to and click paste.

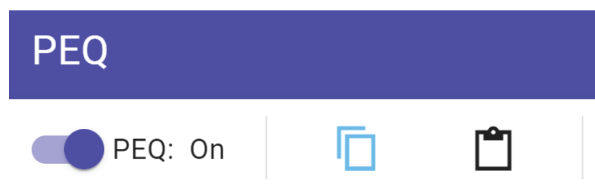

Equalizer Applications

Conferencing room acoustics vary based on room size, shape, and construction materials. Use the guidelines in following table.

Uses for EQ

EQ Application	Suggested Settings
Treble boost for improved speech intelligibility	Add a high shelf filter to boost frequencies greater than 1 kHz by 3-6 dB
HVAC noise reduction	Add a low cut filter to attenuate frequencies below 200 Hz

EQ Application	Suggested Settings
<p>Reduce flutter echoes and sibilance</p>	<p>Identify the specific frequency range that "excites" the room:</p> <ol style="list-style-type: none"> 1. Set a narrow Q value. 2. Increase the gain to between +10 and +15 dB, and then experiment with frequencies between 1 kHz and 6 kHz to pinpoint the range of flutter echoes or sibilance. 3. Reduce the gain at the identified frequency (start between -3 and -6 dB) to minimize the unwanted room sound.
<p>Reduce hollow, resonant room sound</p>	<p>Identify the specific frequency range that "excites" the room:</p> <ol style="list-style-type: none"> 1. Set a narrow Q value. 2. Increase the gain to between +10 and +15 dB, and then experiment with frequencies between 300 Hz and 900 Hz to pinpoint the resonant frequency. 3. Reduce the gain at the identified frequency (start between -3 and -6 dB) to minimize the unwanted room sound.

EQ Contour

Use the EQ contour to quickly apply a high-pass filter at 150 Hz to the microphone's signal.

Select EQ contour to turn it on or off.

Mute Points in Control Software

The MXA925 has multiple mute points in Designer or the web application. The number of mute points depends on if automatic coverage is on or off.

Mute Points (Automatic Coverage On)

There are 2 mute points when automatic coverage is on:

1. **Automix output mute:** Mutes the automix output channel
2. **Device mute:** Mutes the device. This mute button also changes the status LED.

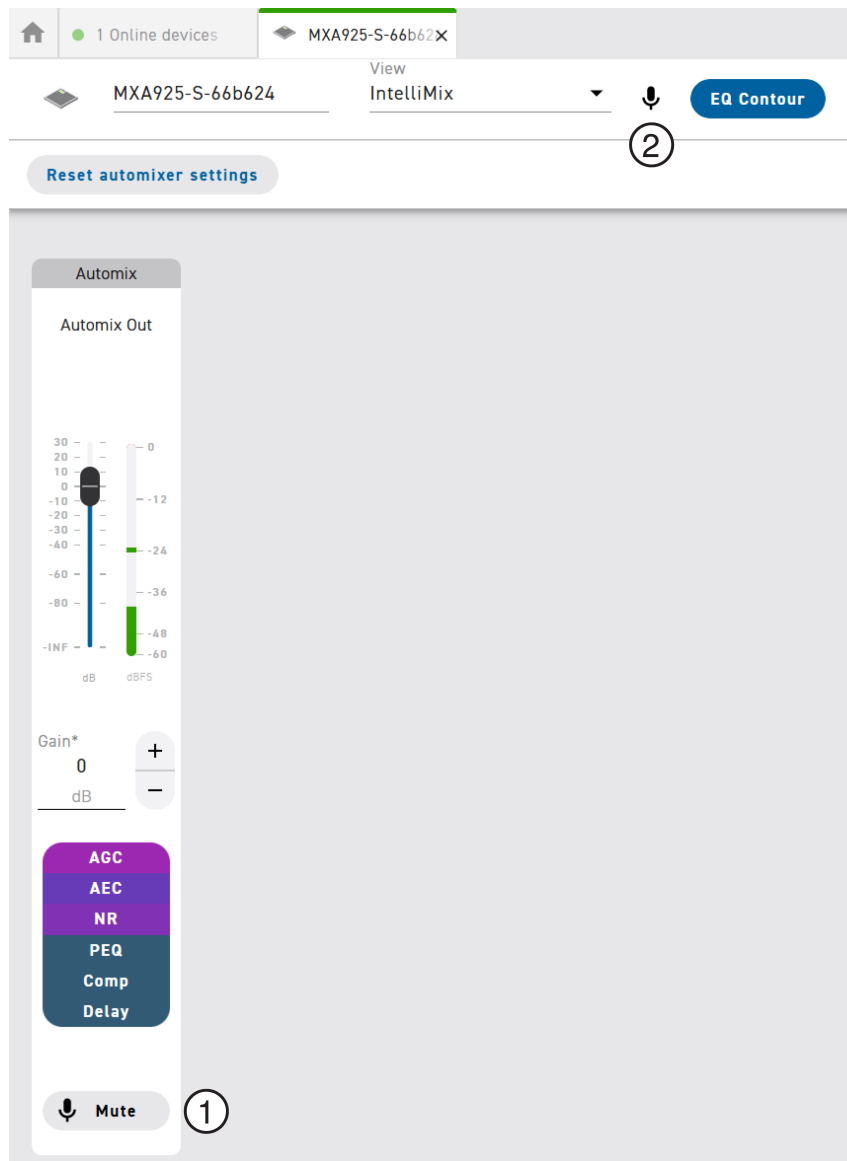

Mute Points (Automatic Coverage Off)

There are 4 mute points when automatic coverage is off:

1. **Pre-gate channel mute:** Mutes the selected direct output channel
2. **Automix output mute:** Mutes the automix output channel
3. **Device mute:** Mutes the device. This mute button also changes the status LED.
4. **Post-gate channel mute:** Mutes the channel after the automixer gating has happened

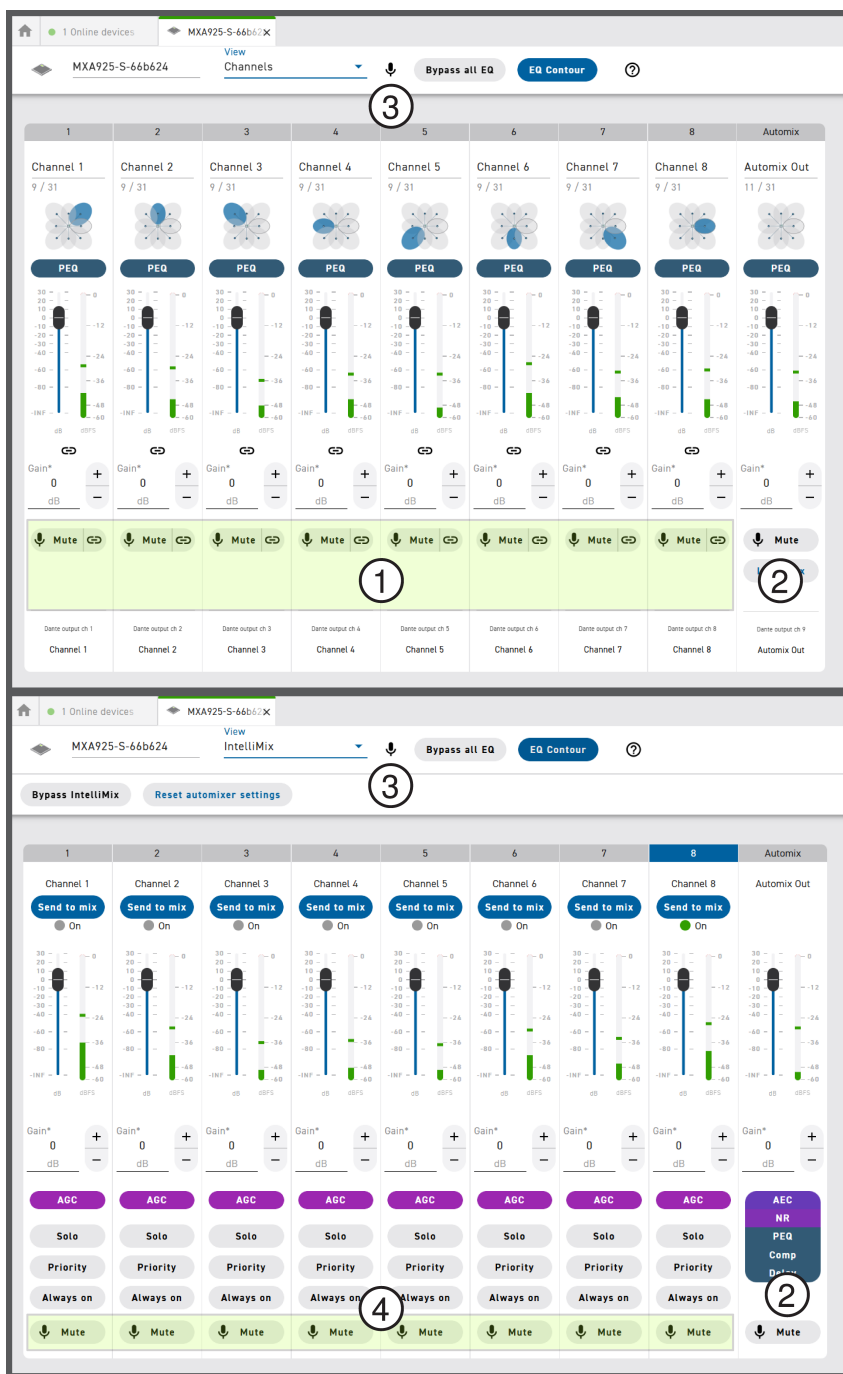

IntelliMix DSP Settings

This device contains IntelliMix digital signal processing blocks that can be applied to the microphone's output. The DSP blocks include:

- AI acoustic echo cancellation (AI AEC)
- Automatic gain control (AGC)
- Noise reduction
- AI deverb

- AI denoiser
- Compressor
- Delay

To access, go to the IntelliMix view. Double-click a DSP block to open the settings.

DSP Best Practices

- Apply DSP blocks as needed. Run a test of your system without DSP and then add processing as needed to fix any issues that you hear in the audio signal.
- Use [Designer's auto route](#) as a DSP starting point. The auto route process applies Shure's recommended DSP settings for the room's mix of devices. You can then customize settings to fit your needs.
- Avoid duplicating DSP blocks.
 - Example: If you plan to use a mic's noise reduction processing, turn off the noise reduction on any connected processors (Shure or third-party). Conversely, if you use noise reduction on a connected processor, turn off the mic's noise reduction.
- Unless you encounter video that lags behind audio, set delay to off.

AI Acoustic Echo Cancellation (AEC)

Tackle acoustically challenging spaces more easily with Shure's AI AEC processing. The algorithm offers streamlined settings and faster deployment times compared to Shure's standard AEC.

AI AEC improvements include:

- Better performance in any room, even when there are poor acoustics or the mic is close to loudspeakers
- Ability to stay with moving talkers, no convergence time required
- Faster deployment, thanks to training on a wide variety of rooms

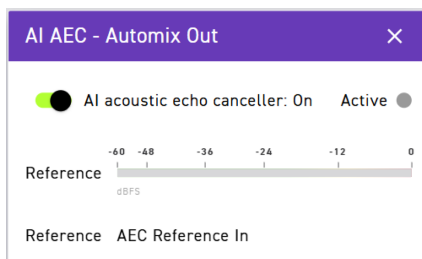

What is AI AEC For?

AI AEC algorithms work to keep your microphone signal clear and free of distracting echo on calls. AEC is a benefit for everyone else on a call: they hear you clearly with no annoying echo.

Echo happens when your microphone picks up sound from your loudspeakers and sends it back to others on the call as echo.

AI AEC Tips

When possible, optimize the acoustic environment using these tips:

- Reduce loudspeaker volume.
- Position loudspeakers farther from microphones.
- Avoid pointing loudspeakers directly at microphone coverage areas.

- Avoid duplicating AEC processing.
 - Example: If you plan to use a mic's AEC processing, turn off the AEC on any connected processors (Shure or third-party). Conversely, if you use AEC on a connected processor, turn off the mic's AEC.
 - Designer's [auto route process](#) selects Shure's recommended device for AEC processing based on the mix of Shure devices in the room.

AI AEC processing does not actively train on any audio signals while in use. AI models are trained offline during development and then embedded into the product. Any improvements to AI AEC processing come with firmware updates.

For more information about how AI is used in Shure products, [see our AI in Our Audio and Video Products whitepaper](#).

Provide a Reference Signal for AEC

To apply AEC, provide a far end reference signal. For best results, use the same signal that feeds the room's local reinforcement system.

Designer's auto route process automatically routes an AEC reference signal. However, you should check that Designer chooses the reference signal you want to use.

To provide a reference signal, use Designer or Dante Controller to route the far end reference signal to the device's AEC Reference In channel.

Note: Always send an AEC reference signal to microphones with AEC processing, even if you are using a separate DSP for AEC. Some microphones use this reference signal to help improve mic coverage. Designer's auto route feature automatically creates these routes.

AI AEC Settings

Reference meter	Use the reference meter to visually verify the reference signal is present. The reference signal should not be clipping.
Reference	Indicates which channel is serving as the far-end reference signal.
Active indicator	When on, shows that AI AEC is working correctly.

Noise Reduction

Noise reduction keeps the focus on your voice by reducing the level of background noise. Noise reduction is best for constant noise sources such as:

- Loud HVAC systems
- Network switch or server fans
- Display projectors

Noise reduction is a dynamic processor which calculates the noise floor in a room and removes noise throughout the entire spectrum with maximum transparency.

Settings

Options: Low, medium, high, or auto

The noise reduction setting reflects the amount of reduction in dB.

For best results, use the Auto setting so that the noise reduction level adapts to changes in the acoustic environment.

Automatic Gain Control (AGC)

Automatic gain control automatically adjusts channel levels to ensure consistent volume for all talkers in all scenarios. For quieter voices, it increases gain. For louder voices, it attenuates the signal.

Enable AGC on channels where the distance between the talker and the microphone may vary, or in rooms where many different people will use the conferencing system.

Automatic gain control happens post-gate (after the automixer) and does not affect when the automixer gates on or off.

Target Level (dBFS)

Use -37 dBFS as a starting point to ensure adequate headroom and adjust if necessary. This represents the RMS (average) level, which is different from setting the input fader according to peak levels to avoid clipping.

Maximum Boost (dB)

Sets the maximum amount of gain that can be applied

Maximum Cut (dB)

Sets the maximum attenuation that can be applied

Tip: Use the boost/cut meter (not available on all microphones) to monitor the amount of gain added or subtracted from the signal. If the meter is always reaching the maximum boost or cut level, adjust the input fader so the signal is closer to the target level.

Delay

Use delay to synchronize audio and video. When a video system introduces latency (where you hear someone speak, and their mouth moves later), add delay to align audio and video.

Delay is measured in milliseconds. If there is a significant difference between audio and video, start by using larger intervals of delay time (500-1000 ms). When the audio and video are slightly out of sync, use smaller intervals to fine-tune.

Compressor

Use the compressor to control the dynamic range of the selected signal.

Threshold

When the audio signal exceeds the threshold value, the level is attenuated to prevent unwanted spikes in the output signal. The amount of attenuation is determined by the ratio value. Perform a soundcheck and set the threshold 3-6 dB above average talker levels, so the compressor only attenuates unexpected loud sounds.

Ratio

The ratio controls how much the signal is attenuated when it exceeds the threshold value. Higher ratios provide stronger attenuation. A lower ratio of 2:1 means that for every 2 dB the signal exceeds the threshold, the output signal will only exceed the threshold by 1 dB. A higher ratio of 10:1 means a loud sound that exceeds the threshold by 10 dB will only exceed the threshold by 1 dB, effectively reducing the signal by 9 dB.

AI Deverb

AI deverb helps improve the mic signal going to the far end by reducing the amount of reverb. Use deverb in rooms that:

- Have lots of hard, reflective surfaces
- Don't have proper acoustic treatment

To turn on deverb, open the mic's control software and go to IntelliMix > AI Deverb. Deverb is available on the automix output signal.

Choose from 3 intensity options: low, medium, or high.

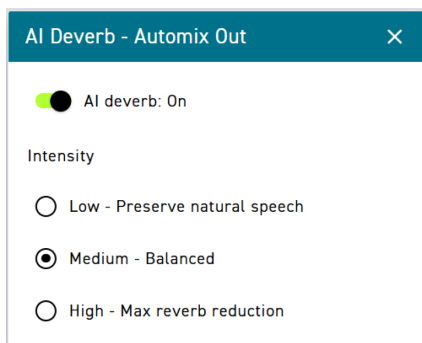

Best Practices

- Make a test call with your videoconferencing software and have someone on the other end tell you how your signal sounds as you test each deverb setting.
- In rooms with multiple mics, use deverb on all mics. If you only turn on deverb for 1 mic, downstream processors will encounter problems with delay and gating. See the latency specifications for more information.

AI Denoiser

The AI denoiser identifies and reduces the level of noises such as typing, shuffling papers, or slamming doors. These noises can be inside or outside of an active talker's lobe. When the denoiser detects noise, it reduces the noise so your voice comes through clearly.

The denoiser adjusts for random noises that aren't always present in your audio signal, whereas noise reduction helps control constant background noise. For best results, use both the denoiser and noise reduction.

Use the meter to check that the denoiser is actively suppressing noise. The denoiser is applied to the automix output signal.

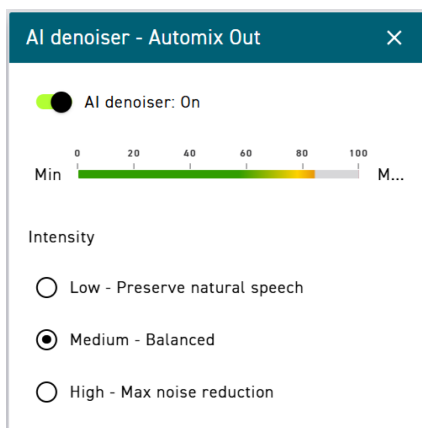

How it Works

Shure trains the AI denoiser with thousands of audio files. These include speech samples, noise samples, and samples that have mixtures of speech and noise. During this training, the denoiser learns how to identify patterns of speech and non-speech content in the frequency spectrum. It can then identify and preserve the speech content and reduce the non-speech content.

AI training or listening only happens at Shure's labs. You will receive any improvements to the AI denoiser algorithm when you update to the latest firmware.

See our [whitepaper about how AI is used](#) in our audio and video products for more information.

Settings

Settings indicate how much the denoiser lowers the level of noises. High significantly reduces noises, while low minimally reduces noises. Using the denoiser can affect speech levels if noise and speech happen at the same time. The effect varies with the type of noise and how loud it is.

Listen to and test the different settings to find one that works best in your space.

Automix Channel

The mic's automix output channel automatically mixes the audio from coverage areas or lobes to deliver a convenient, single output.

Adjust automix output gain and other settings in the IntelliMix view. Route the automix channel to the desired destination using Designer or Dante Controller.

The automatic coverage setting changes some of the setting options for the automix output channel. See below for details.

MXA925 Automix Settings

The settings on the IntelliMix page control automixer settings, post-gate gain and channel settings, and IntelliMix DSP settings.

To adjust automixer settings, go to [IntelliMix > Properties](#).

Automix Settings (Automatic Coverage On)

The screenshot displays the MXA925 automixer settings interface. At the top, the device name is 'MXA925-S-66b624' and the view is 'IntelliMix'. A green 'EQ Contour' button is visible. Below this is a 'Reset automixer settings' button. The main interface is divided into two sections: 'Automix' and 'Properties'.

The 'Automix' section includes a 'Gain' control set to 0 dB and a list of processing options: AGC, AI AEC, NR, AI Deverb, AI Denois..., PEQ, Comp, and Delay. A 'Mute' button is located at the bottom of this section.

The 'Properties' section shows the following settings:

- Off attenuation ***: -40 dB (1)
- Hold time ***: 400 ms (2)
- Gating sensitivity**: Slidable control (3)
- Virtual acoustic boundary**: Off (4)
- Strength**: Slidable control (5)
- Speech gating threshold**: Low (5)

MXA925 automix setting options when automatic coverage is on

1. Off attenuation: Sets the level of signal reduction in dB for when a channel is not active
2. Hold time: Sets how long a channel remains open after the level drops below the gate threshold
3. Gating sensitivity: Changes the threshold level at which the gate is opened and a channel becomes active
4. [Virtual acoustic boundary](#): Removes unwanted sounds from outside coverage areas in the mic's automix output signal
5. [Speech gating threshold](#): Improves automixer gating and focuses on speech sources over noise sources

Automix Settings (Automatic Coverage Off)

MXA925 automix setting options when automatic coverage is off

1. Bypass IntelliMix: Toggles all IntelliMix DSP settings on or off
2. Send to mix: When turned on, sends the channel to the automix output
3. Solo: Solos the selected channel
4. Priority: When selected, this channel gate activates regardless of the number of maximum open channels.
5. Always on: Keeps the channel open at all times
6. Bypass all EQ: Toggles all EQ settings on or off
7. **Automix mode** selector: Changes the automixer gating behavior
8. Automix gain meter: When enabled, changes gain meters to display automix gating in real time. Channels that gate open will display more gain than channels that are closed (attenuated) in the mix.
9. Maximum open channels: Sets the maximum number of simultaneously active channels
10. Leave last mic on: Keeps the most recently used microphone channel active
11. Off attenuation: Sets the level of signal reduction in dB for when a channel is not active
12. Hold time: Sets how long a channel remains open after the level drops below the gate threshold
13. Gating sensitivity: Changes the threshold level at which the gate is opened and a channel becomes active
14. **Speech gating threshold**: Improves automixer gating and focuses on speech sources over noise sources

Remove Unwanted Sounds with the Virtual Acoustic Boundary

The virtual acoustic boundary adds more power to the edge of the microphone's coverage area.

When the virtual acoustic boundary is off, the microphone picks up sound that acoustically carries from outside an active coverage area at low levels. This background sound can still be distracting for listeners.

Turn on the virtual acoustic boundary to remove sound from outside coverage areas. The fader adjusts how much sound from outside the coverage area is removed from the microphone's automix output.

Note: The virtual acoustic boundary only works when automatic coverage is on.

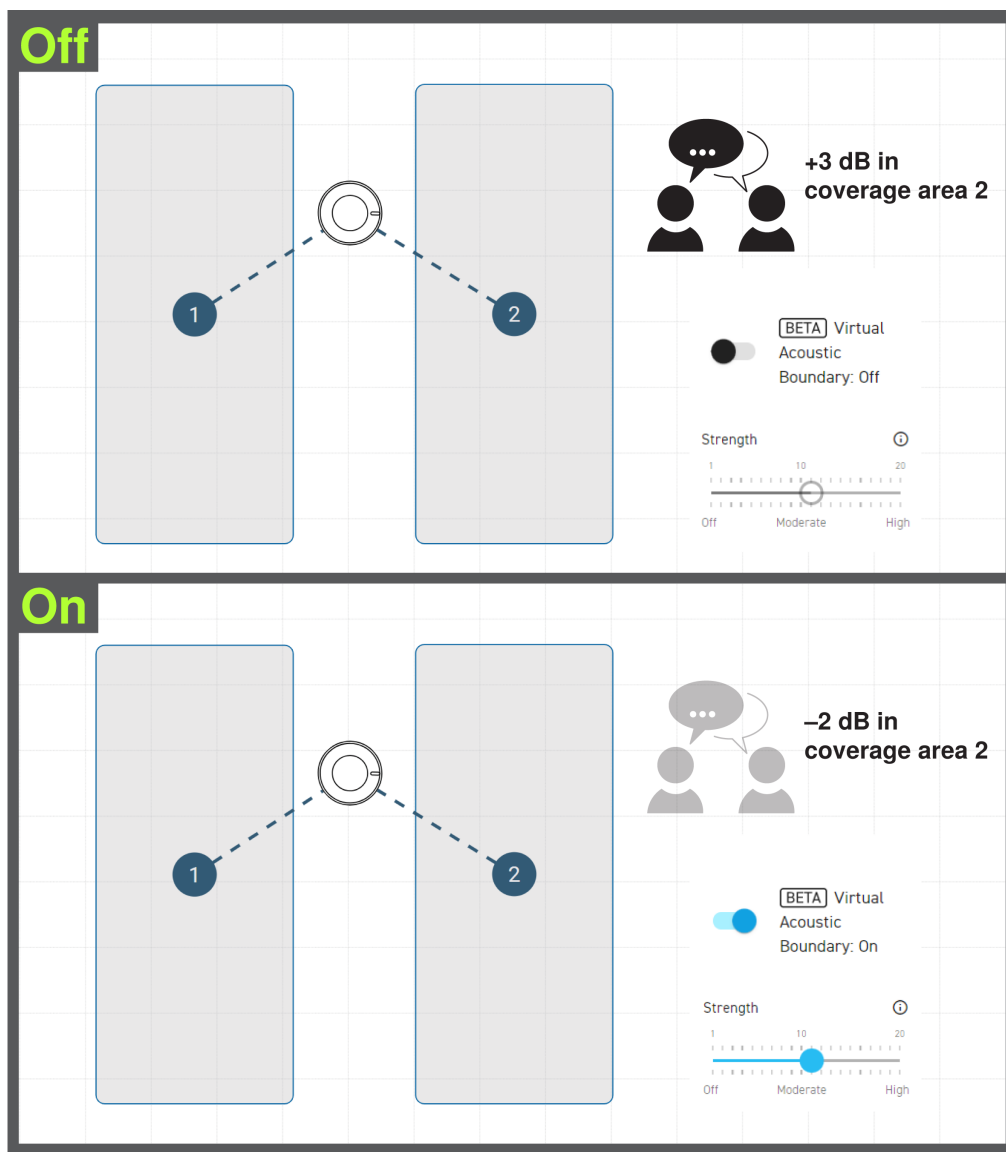

To use the virtual acoustic boundary:

1. In the microphone's control software, go to IntelliMix > Properties. Scroll down to turn on the virtual acoustic boundary.
2. To test, make a call. While you talk, have someone outside of the defined coverage area talk or make noise at the same time.
3. Start with the medium default setting and use the fader to adjust as needed for your room. Have someone on the other end tell you how your signal sounds.

Tips

- A higher setting removes more sound from outside the coverage area. A lower setting removes less sound.
- Results may vary in small, highly reverberant rooms. Install acoustic treatment to improve speech intelligibility.

Speech Gating Threshold

Speech gating threshold enhances the microphone's sound with:

- Improved automixer gating

- More focus on speech sources over noise sources

Examples of noise include:

- Shuffling papers across the table from a person talking
- Keyboard across the table from a person talking
- Loud food container across the table from a person talking

The Low setting is better at preserving speech, whereas the High setting is more aggressive at gating off for noise sources.

To use speech gating threshold:

1. Go to IntelliMix > Properties. Set the speech gating threshold to High as a starting point.
2. Make a test call from a room with 2 people to test the speech gating threshold settings.
3. Have both people in the room talk at the same time. The far-end listener should listen for unwanted speech attenuation. If there is speech attenuation, lower the speech gating threshold setting. Repeat until there is no unwanted speech attenuation.

Tips for Using Speech Gating Threshold

- A high speech gating threshold may detect unvoiced speech sound as noise. If you notice this, lower the speech gating threshold.
- If using with automatic coverage off and leave last mic on set to off, set the speech gating threshold to low. With this setup, the microphone won't gate off if speech is quiet in comparison to noise.

Automix Modes

The automix mode changes the mic's gating behavior (how and when it adds/removes channels from the automix output signal). Automix mode options are available when automatic coverage is turned off.

After choosing a mode, test the gating behavior in the space, adjusting the off attenuation, maximum number of open channels, input gain, and other settings to dial in a good sound for the room.

To select an automix mode, turn off automatic coverage and go to IntelliMix > Properties > Settings.

Available automix modes:

Gain Sharing

Gain sharing mode dynamically balances system gain between open and closed channels. The system gain remains consistent by distributing gain across channels to equal one open channel. The scaled gain structure helps to reduce noise when there is a high channel count. When fewer channels are used, the off attenuation setting is lower and provides transparent gating.

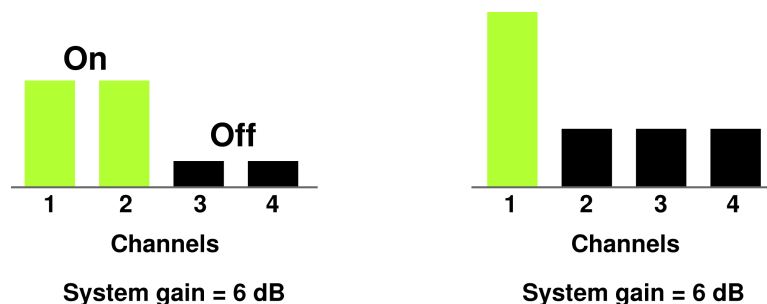

Both graphs show the same total system gain, regardless of the number of open or closed channels

Gating

Gating mode delivers fast-acting, seamless channel gating and consistent perceived ambient sound levels. The off attenuation value is applied to all inactive channels, regardless of the number of active channels.

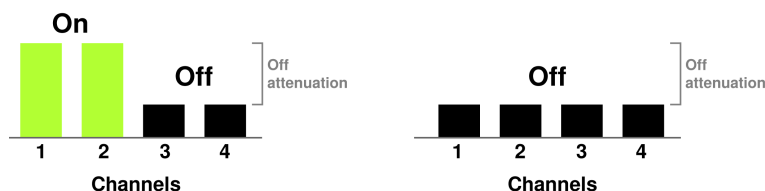

Example showing how off attenuation is applied to all inactive channels in gating mode

Manual

Manual mode sums all active channels and sends the summed signal over a single Dante output. This provides the option to route an individual signal for reinforcement or recording without using automixing. The level from each channel's input gain fader is used for the summed output.

Mute Sync

It's important to be able to see if a room is muted or unmuted during a call. You want devices to show the same mute status as the videoconferencing software. Shure devices use logic and mute sync to make this happen.

- **Logic:** Aligns mute status across Shure devices in the room. The processor or access point is the controller.
- **Mute sync:** Aligns mute between the processor and the videoconferencing software, which is on a computer connected to the processor by USB. The processor's automix output is muted or unmuted to change the mute status of the system.

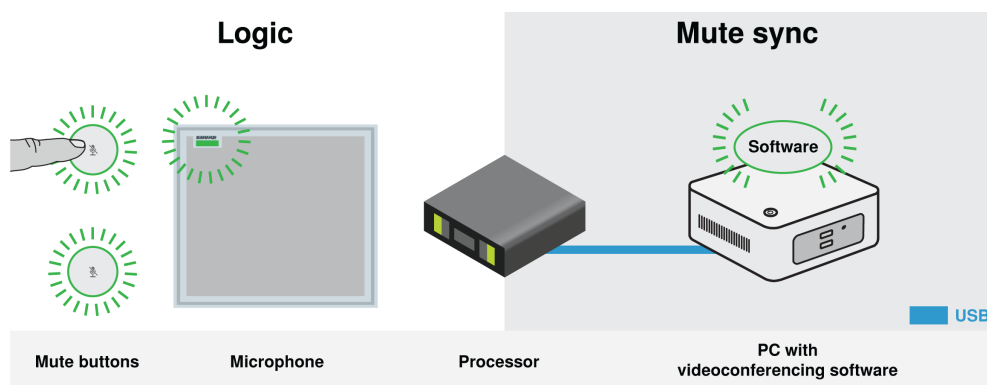

When mute sync is working correctly, you can mute a device ([networked mute button](#) or microphone mute button) or the videoconferencing software to mute the room.

To use mute sync:

1. In Designer, create audio and mute control routes between devices in the room.
2. Connect a computer with videoconferencing software to the processor's USB port.
3. Turn on mute sync and logic:
 - Processors: [Your device] > Settings > Mute control

- MXA320, MXA310 ,and MXA mute button: Settings > Logic control > Mute control function > Logic out
- Microphones without physical mute button: Logic is always on

Designer's auto route process configures all necessary mute sync and logic settings for you.

Compatible Shure Logic Devices

- P300 (Also mutes [supported soft codecs](#) connected by USB)
- ANIUSB-MATRIX (Also mutes [supported soft codecs](#) connected by USB)
- IntelliMix Room software (Also mutes [supported soft codecs](#) connected by USB)
- ANIUSB-C
- MXA901
- MXA902
- MXA910
- MXA920
- MXA925
- MXA710
- MXA320
- MXA310
- Network Mute Button
- ANI22-BLOCK
- ANI4IN-BLOCK
- Logic-enabled MX microphones connected to ANI22-BLOCK or ANI4IN-BLOCK
 - MX392
 - MX395-LED
 - MX396
 - MX405/410/415 used with MX400DP base
 - MX412D
 - MX418D

For help with specific mute sync implementations, [see our FAQs](#).

Use Presets

Use presets to save device settings so that you can quickly recall them later. Presets capture all current device settings but do not save routing information.

To save or apply presets, go to the device's Presets view in Designer or the web application. There are 10 preset slots available on the device.

Designer has room presets and device presets. Learn more in the [Designer user guide](#).

Save a Preset

1. Go to Presets.
2. Select an open preset slot.
3. Enter a name for the preset and save.

Apply a Preset

1. Go to Presets.

2. Choose the preset you want to apply.
3. Select Apply. The applied preset has a check mark next to it.

Note: Any changes made after applying a preset are not saved to that preset. Save new settings to a new preset slot or overwrite the old preset.

Security

Encryption

Audio is encrypted with the Advanced Encryption Standard (AES-256), as specified by the US Government National Institute of Standards and Technology (NIST) publication FIPS-197. Shure devices that support encryption require a password to make a connection. Encryption is not supported with third-party devices.

In Designer, you can turn on encryption for all devices in a room: [Your room] > Settings > Audio encryption.

To activate encryption in the web application, go to Settings > Audio encryption > Enable encryption.

Important: For encryption to work:

- All Shure devices on your network must use encryption.
- Disable AES67 in Dante Controller. AES67 and AES-256 cannot be used at the same time.

Set Up the 802.1X Protocol for a Device

Select Shure devices support the IEEE 802.1X port access protocol for network authentication.

Important: To use the 802.1X security protocol with Shure devices, set the network switch to multiple host authentication. You must also make accommodations to allow the audio NIC to connect to the network. The audio NIC doesn't support the 802.1X protocol.

To set up 802.1X, you will need:

- Details about your authentication server's EAP method
- Any required credentials or certificates for that method, for example:
 - MD5 and PWD
 1. User ID and passphrase
 - TLS and PEAP
 1. User ID and passphrase
 2. Certificate (with certificate types) in the .PEM format
- Any passwords to access the devices if they are password locked

Setting up 802.1X is a two-part process.

Step 1: Configure Settings on Test Network

1. Connect the device to a test network that *does not* have 802.1X enabled, and discover it using Designer.
2. Set a device password if desired.
3. Double-click the device and go to Settings > Network > 802.1X.
4. Choose your EAP method from the menu.
5. Enter any required credentials and load any necessary certificates.
6. Press Save to save the 802.1X settings to the device.
7. Enable 802.1X and select Reboot now.

Step 2: Connect to a Credentialed Network

1. Connect your device to the credentialed network.
2. Ensure that Designer is connected to the credentialed network.
3. Verify that the device appears in Designer. If it doesn't, reconnect to the test network and check all 802.1X settings for the selected EAP method.

Choose a Switch Configuration Setting for 802.1X

For devices with 2 RJ45 ports, 802.1X behavior varies depending on the device's switch configuration setting (Settings > IP configuration > Switch configuration).

Use the information below to help choose a switch configuration setting for the device that fits your security needs. MAC Authentication Bypass can be used alongside or instead of 802.1X, depending on the device's switch configuration setting.

802.1X with Bimodal Setting

Primary Port (1 PoE)	Secondary Port (2)
Primary Shure control (Designer and web application) Primary Dante audio	Secondary Shure control (ShureCloud)

Use the secondary port for 802.1X authentication. The secondary port does not carry Dante audio.

Important: When one port is used for authentication, connecting a device to the other port grants that device access to the credentialed network without authenticating it. This access may not be desirable for your credentialed network. To prevent this, use [MAC Authentication Bypass \(MAB\)](#) in addition to 802.1X.

802.1X with Switched Setting

Primary Port (1 PoE)	Secondary Port (2)
Primary Shure control Primary Dante audio	Primary Shure control Primary Dante audio

Use either the primary or the secondary port for 802.1X authentication.

Important: When one port is used for authentication, connecting a device to the other port grants that device access to the credentialed network without authenticating it. This access may not be desirable for your credentialed network. To prevent this access, you can either:

- Turn off unused network ports (Settings > IP configuration), or
- Use [MAC Authentication Bypass \(MAB\)](#) in addition to 802.1X

802.1X with Redundant Setting

Primary Port (1 PoE)	Secondary Port (2)
Primary Shure control Primary Dante audio	Secondary Dante audio

Use the primary port for authentication. The secondary port does not support 802.1X.

If authentication to the credentialed network is required on the secondary port, use [MAC Authentication Bypass \(MAB\)](#) instead.

Important: Connecting a device to the secondary port will not grant that device access to the credentialed network.

Use the Redundant switch configuration setting when both audio and control are needed.

802.1X with Split Setting

Primary Port (1 PoE)	Secondary Port (2)
Primary Shure control	Primary Dante audio

Use the primary port for authentication. The secondary port does not support 802.1X.

If authentication to the credentialed network is required on the secondary port, use [MAC Authentication Bypass \(MAB\)](#) instead.

Important: Connecting a device to the secondary port will not grant that device access to the credentialed network.

Only control data is available on the credentialed network in with the Split switch configuration setting. If you need audio on the credentialed network, use the Redundant switch configuration setting.

Turn Off or Clear 802.1X Settings

You can turn off 802.1X settings temporarily, or clear them from the device. Open the device and go to Settings > Network > 802.1X

- **Disable:** Click the 802.1X switch to turn off 802.1X settings. Click the switch again to enable 802.1X.
- **Clear:** Click Clear 802.1X settings to remove 802.1X settings from the device.

Note: Resetting to factory default clears all 802.1X settings.

Change 802.1X Settings

You may need to change a device's 802.1X settings if the enterprise's 802.1X settings are changing. The best way to do this is to change the 802.1X settings on the devices, and then make changes to the authentication server.

To change device settings:

1. While still connected to the credentialed network, find the device in Designer and go to Settings > Network > 802.1X.
2. Make changes and click Save.
3. Make any changes to the authentication server.
4. Reboot your devices. The devices should connect to the credentialed network with the updated 802.1X settings.

Troubleshooting 802.1X Setup Issues

If the device doesn't appear in Designer on the credentialed network, there's a problem with the device's 802.1X settings. To troubleshoot, take the device off the credentialed network and connect it to the test network. You can make any necessary changes to the 802.1X settings, and then reconnect to the credentialed network.

If you attempt to enable 802.1X on a device, but the authentication fails, you will see this notification:

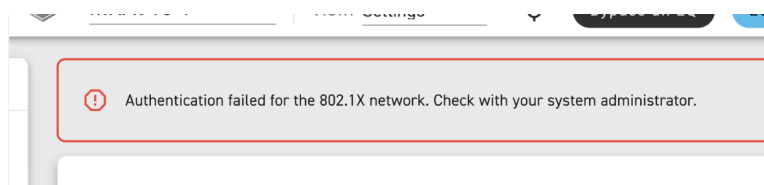

If this occurs, check with your system administrator.

MAC Authentication Bypass

MAC Authentication Bypass (MAB) is a network access control method used primarily in managed networks. MAB grants network access to devices based on their MAC addresses when other authentication protocols, such as 802.1X, are not available or supported.

In switched mode, when the device has 802.1X enabled, both RJ45 ports provide access to the credentialed network. If this is not desired, the network administrator must also use MAB to prevent unauthorized devices from accessing the credentialed network via the second port.

In the split and redundant network modes, the Dante interface on the secondary port does not support 802.1X. Therefore, if access to the credentialed network is required on these ports, the network administrator must use MAB.

Networking

Networking Best Practices

When connecting Shure devices to a network, use the following best practices:

- Always use a "star" network topology by connecting each device directly to the switch or router.
- For most uses, connect Shure networked devices to the same network and set to the same subnet.
 - If needed, use Designer to [discover devices across subnets](#).
- Disable unused network ports on Shure devices when possible.
- Allow all Shure software through the firewall on your computer.
- Use only 1 DHCP server per network. Disable DHCP addressing on additional servers.
- Power on the switch and DHCP server before powering on the Shure devices.
- To expand the network, use multiple switches in a star topology.
- Keep device firmware updated to avoid compatibility issues.

Switch and Cable Recommendations for Dante Networking

Switches and cables determine how well your audio network performs. Use high-quality switches and cables to make your audio network more reliable.

Network switches should have:

- Gigabit ports. 10/100 switches may work on small networks, but gigabit switches perform better.
- Power over Ethernet (PoE) or PoE+ ports for any devices that require power
- Management features to provide information about port speed, error counters, and bandwidth used
- Ability to switch off Energy Efficient Ethernet (EEE). EEE (also known as "Green Ethernet") may cause audio dropouts and problems with clock synchronization.
- Diffserv (DSCP) Quality of Service (QoS) with strict priority and 4 queues

Ethernet cables should be:

- Cat5e or better
- Shielded

For more information, [see our FAQ](#) about switches to avoid.

Setting Latency

Latency is the amount of time for a signal to travel across the system to the outputs of a device. To account for variances in latency time between devices and channels, Dante has a predetermined selection of latency settings. When the same setting is selected, it ensures that all Dante devices on the network are in sync.

These latency values should be used as a starting point. To determine the exact latency to use for your setup, deploy the setup, send Dante audio between your devices, and measure the actual latency in your system using Audinate's Dante Controller software. Then round up to the nearest latency setting available, and use that one.

Use Audinate's Dante Controller software to change latency settings.

Latency Recommendations

Latency Setting	Maximum Number of Switches
0.25 ms	3
0.5 ms (default)	5
1 ms	10
2 ms	10+

QoS (Quality of Service) Settings

QoS settings assign priorities to specific data packets on the network, ensuring reliable audio delivery on larger networks with heavy traffic. This feature is available on most managed network switches. Although not required, assigning QoS settings is recommended.

Note: Coordinate changes with the network administrator to avoid disrupting service.

To assign QoS values, open the switch interface and use the following table to assign Dante[®]-associated queue values.

- Assign the highest possible value (shown as 4 in this example) for time-critical PTP events
- Use descending priority values for each remaining packet.

Dante QoS Priority Values

Priority	Usage	DSCP Label	Hex	Decimal	Binary
High (4)	Time-critical PTP events	CS7	0x38	56	111000
Medium (3)	Audio, PTP	EF	0x2E	46	101110
Low (2)	(reserved)	CS1	0x08	8	001000
None (1)	Other traffic	BestEffort	0x00	0	000000

Note: Switch management may vary by manufacturer and switch type. Consult the manufacturer's product guide for specific configuration details.

For more information on Dante requirements and networking, visit www.audinate.com.

Networking Terminology

PTP (Precision Time Protocol): Used to synchronize clocks on the network

DSCP (Differentiated Services Code Point): Standardized identification method for data used in layer 3 QoS prioritization

Ports, Protocols, and Firewall Rules

For information about IP ports and protocols or firewall rules, go to:

- [IP Ports and Protocols for Shure Devices](#)
- [Firewall Rules for Shure Software Applications](#)

Digital Audio Networking

Dante digital audio is carried over standard Ethernet and operates using standard internet protocols. Dante provides low latency, tight clock synchronization, and high Quality-of-Service (QoS) to provide reliable audio transport to a variety of Dante devices. Dante audio can coexist safely on the same network as IT and control data, or can be configured to use a dedicated network.

Compatibility with Dante Domain Manager

This device is compatible with Dante Domain Manager software (DDM). DDM is network management software with user authentication, role-based security, and auditing features for Dante networks and Dante-enabled products.

Considerations for Shure devices controlled by DDM:

- When you add Shure devices to a Dante domain, set the local controller access to Read Write. Otherwise, you won't be able to access Dante settings, perform a factory reset, or update device firmware.
- If the device and DDM can't communicate over the network for any reason, you won't be able to control Dante settings, perform a factory reset, or update device firmware. When the connection is reestablished, the device follows the policy set for it in the Dante domain.
- If Dante device lock is on, DDM is offline, or the configuration of the device is set to Prevent, some device settings are disabled. These include: Dante encryption, MXW association, AD4 Dante browse and Dante cue, and SCM820 linking.

Refer to [Dante Domain Manager's documentation](#) for more information.

Dante Flows for Shure Devices

Dante flows get created any time you route audio from one Dante device to another. One unicast Dante flow can contain up to 4 audio channels. For example: sending all 5 available channels from an MXA310 to another device uses 2 Dante flows, because 1 flow can contain up to 4 channels.

Every Dante device has a specific number of transmit flows and receive flows. The number of flows is determined by Dante platform capabilities.

Dante Flows for Shure Devices

Dante Platform	Shure Devices Using Platform	Transmit Flow Limit	Receive Flow Limit
Brooklyn II	ULX-D, SCM820, MXWAPT, MXWANI, P300, MXCWAPT	32	32
Brooklyn II (without SRAM)	MXA920, MXA910, MXA902, MXA710, AD4, AD600, APXD2	16	16
IP Core	MXA920-V3, MXA902-V3, MXA901, DCA901, MXA925	32	32
Ultimo/UltimoX	MXA310, ANI4IN, ANI4OUT, ANIUSB-MATRIX, ANI22, MXN5-C	2	2

Dante Platform	Shure Devices Using Platform	Transmit Flow Limit	Receive Flow Limit
DEP	ANIUSB-MATRIX-V3, MXN-AMP, MXN5-C-V3, MXN-6, MXA320, ANIUSB-C	2	2
DAL	IntelliMix Room	16	16

[Learn more about Dante flows in our FAQs](#) or from [Audinate](#).

AES67

AES67 is a networked audio standard that enables communication between hardware components which use different IP audio technologies. This Shure device supports AES67 for increased compatibility within networked systems for live sound, integrated installations, and broadcast applications.

The following information is critical when transmitting or receiving AES67 signals:

- Update Dante Controller software to the newest available version to ensure the AES67 configuration tab appears.
- Before turning encryption on or off, you must disable AES67 in Dante Controller.
- AES67 cannot operate when the transmit and receive devices both support Dante.

Shure Device Supports:	Device 2 Supports:	AES67 Compatibility
Dante and AES67	Dante and AES67	No. Must use Dante.
Dante and AES67	AES67 without Dante. Any other audio networking protocol is acceptable.	Yes

Separate Dante and AES67 flows can operate simultaneously. The total number of flows is determined by the maximum flow limit of the device.

Sending Audio from a Shure Device

All AES67 configuration is managed in Dante Controller software. For more information, refer to the Dante Controller user guide.

1. Open the Shure transmitting device in Dante Controller.
2. Enable AES67.
3. Reboot the Shure device.
4. Create AES67 flows according to the instructions in the [Dante Controller user guide](#).

Receiving Audio from a Device Using a Different Audio Network Protocol

Third-party devices: When the hardware supports SAP, flows are identified in the routing software that the device uses. Otherwise, to receive an AES67 flow, the AES67 session ID and IP address are required.

Shure devices: The transmitting device must support SAP. In Dante Controller, a transmit device (appears as an IP address) can be routed like any other Dante device.

How to Paint the MXA925

You can paint square or round MXA925 ceiling array microphones to match a room's design.

On MXA925-S models, the frame and grille can be painted. On MXA925-R models, the grille and part of the back cover can be painted.

Paint Square Array Microphones

You can paint the grille and frame of square ceiling array microphones to blend in with a room's design.

Note: Don't remove any of the screws on the MXA902's loudspeaker enclosure while painting.

Step 1: Remove the Frame and Grille

1. On each side of the frame, remove the 6 screws and washers that attach the main assembly to the frame.

Important: Do not remove the 4 recessed screws in each corner.

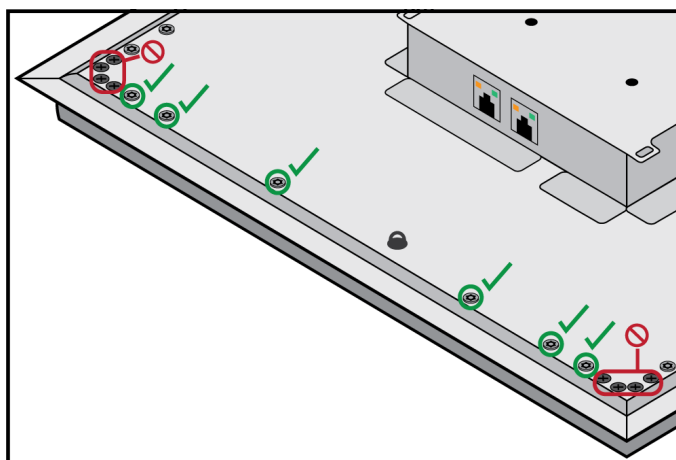

2. Carefully lift the assembly out of the frame.
3. Remove the gray plastic LED lightpipe. Leave the black plastic guide in place.
4. Remove all 4 recessed screws from one side of the frame. Remove that side of the frame.

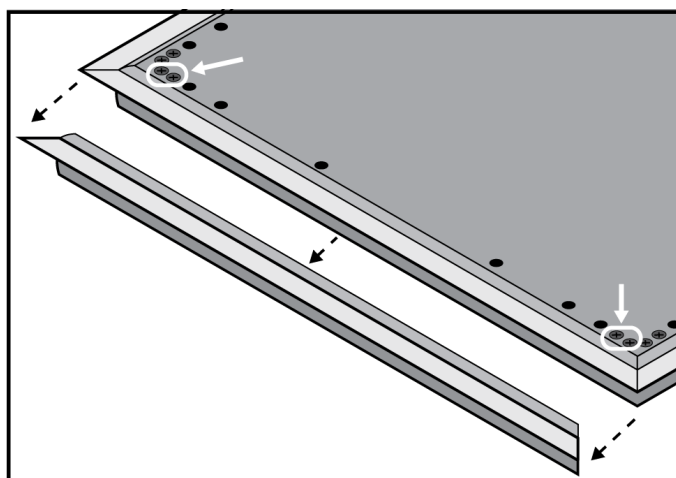

5. Slide the flat grille out of the frame.
6. Carefully remove the foam piece from the grille. Pull from the edges, where it is attached with hook-and-loop fastener strips.

Important: Do not paint the foam.

7. Before painting, reinstall the side of the frame you removed in step 1.4.

Step 2: Mask and Paint

1. Use masking tape to cover the entire extrusion (highlighted in black) that runs along the inside of the frame. This ensures that the necessary metal pieces make contact when reassembled.

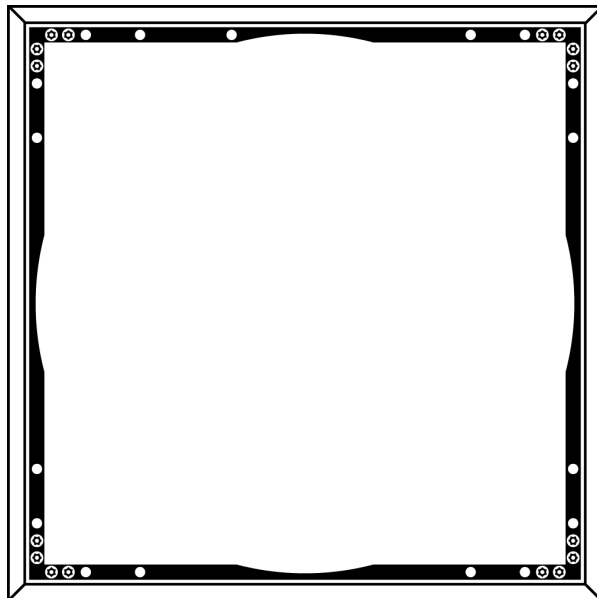

2. Use masking tape to cover the hook-and-loop fastener strips on the grille.
3. Paint the frame and grille. Let them dry completely before reassembling. Do not paint any part of the main assembly.

Step 3: Reassembly

1. Attach the foam piece to the grille with the hook-and-loop fastener strips.
2. Remove one side of the frame as in step 1.4. Slide the grille back into the frame.
3. Attach the remaining side of the frame and secure it with the 4 screws.
4. Attach the LED lightpipe to the black plastic guide piece.
5. Align the LED with the lightpipe and put the main assembly back in place on the frame.

Note: The label on the assembly is in the corner that corresponds to the LED.

6. Install 6 screws per side to secure the main assembly to the frame. Do not over-tighten.

Paint MXA925-R Microphones

The grille and back cover of round array microphones can be painted to blend in with a room's design.

Step 1: Remove and Paint the Grille

1. Loosen the set screw that connects the grille to the back cover. Turn the microphone over.

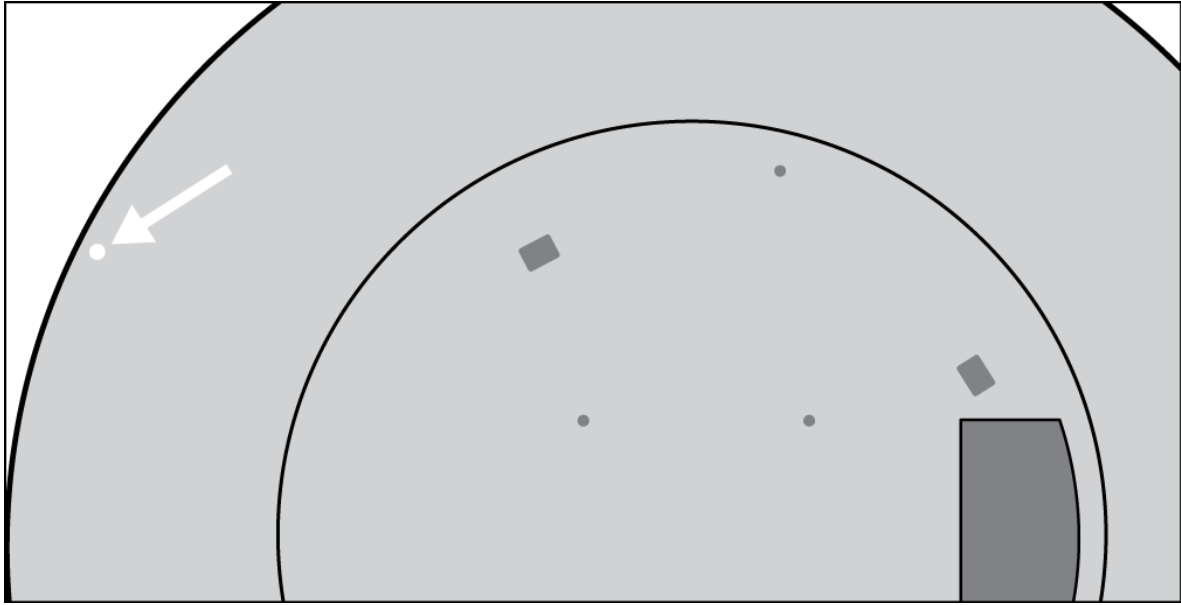

2. Rotate the grille as shown to release it from the back cover. Lift it up and out of the tabs holding it in place.

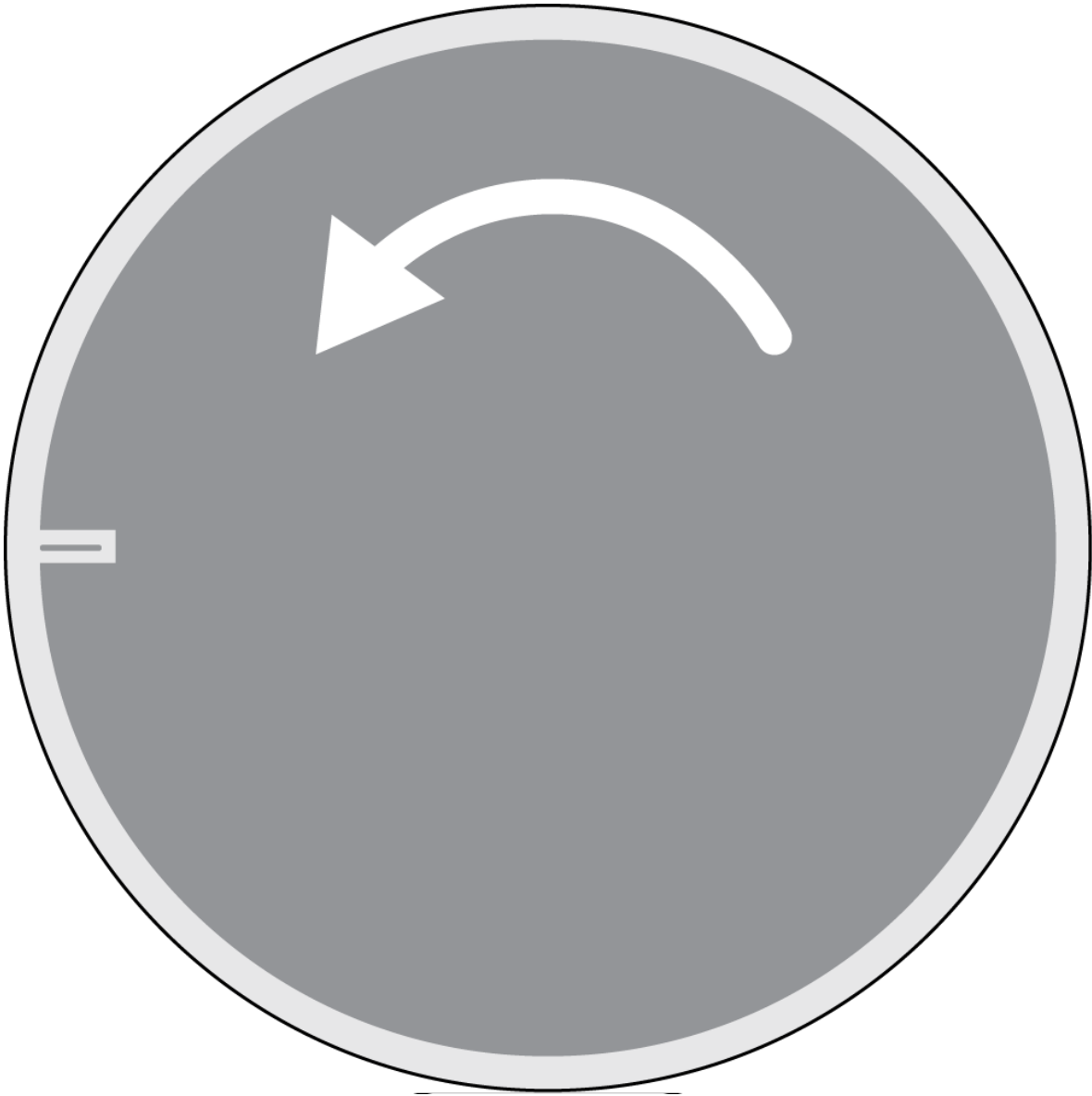

3. Carefully remove the fabric piece from the grille. Pull from the edges where it is attached with Velcro strips. Do not paint the fabric.
4. Hold the edges of the black plastic guide in place and pull up on the clear lightpipe to unsnap it. Leave the guide in place.
5. Mask the 7 bare metal tabs on the grille.

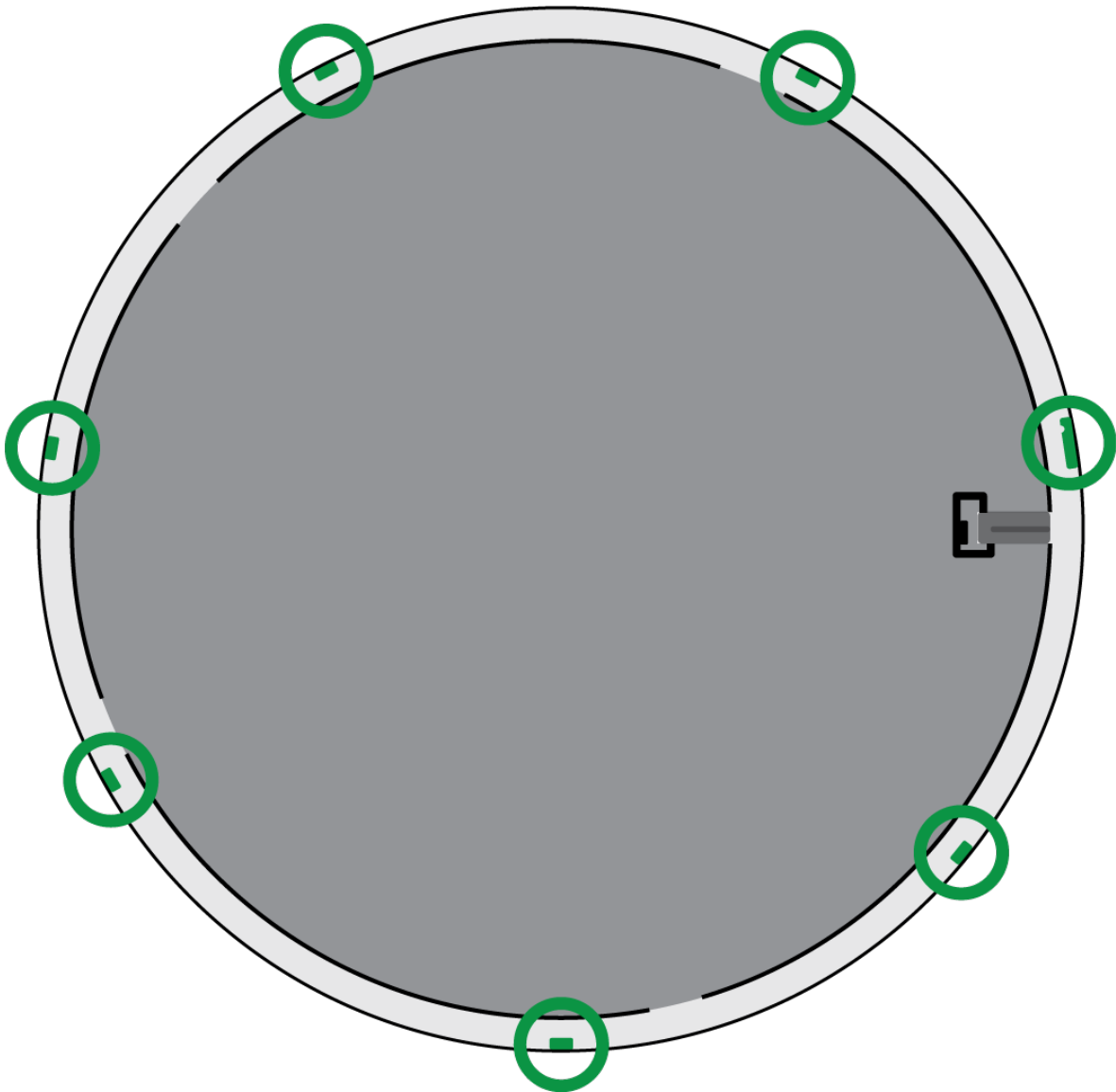

6. Paint the grille.

Step 2: Remove and Paint the Back Cover

1. Remove the 7 screws on the aluminum support panel. Turn the back cover over.

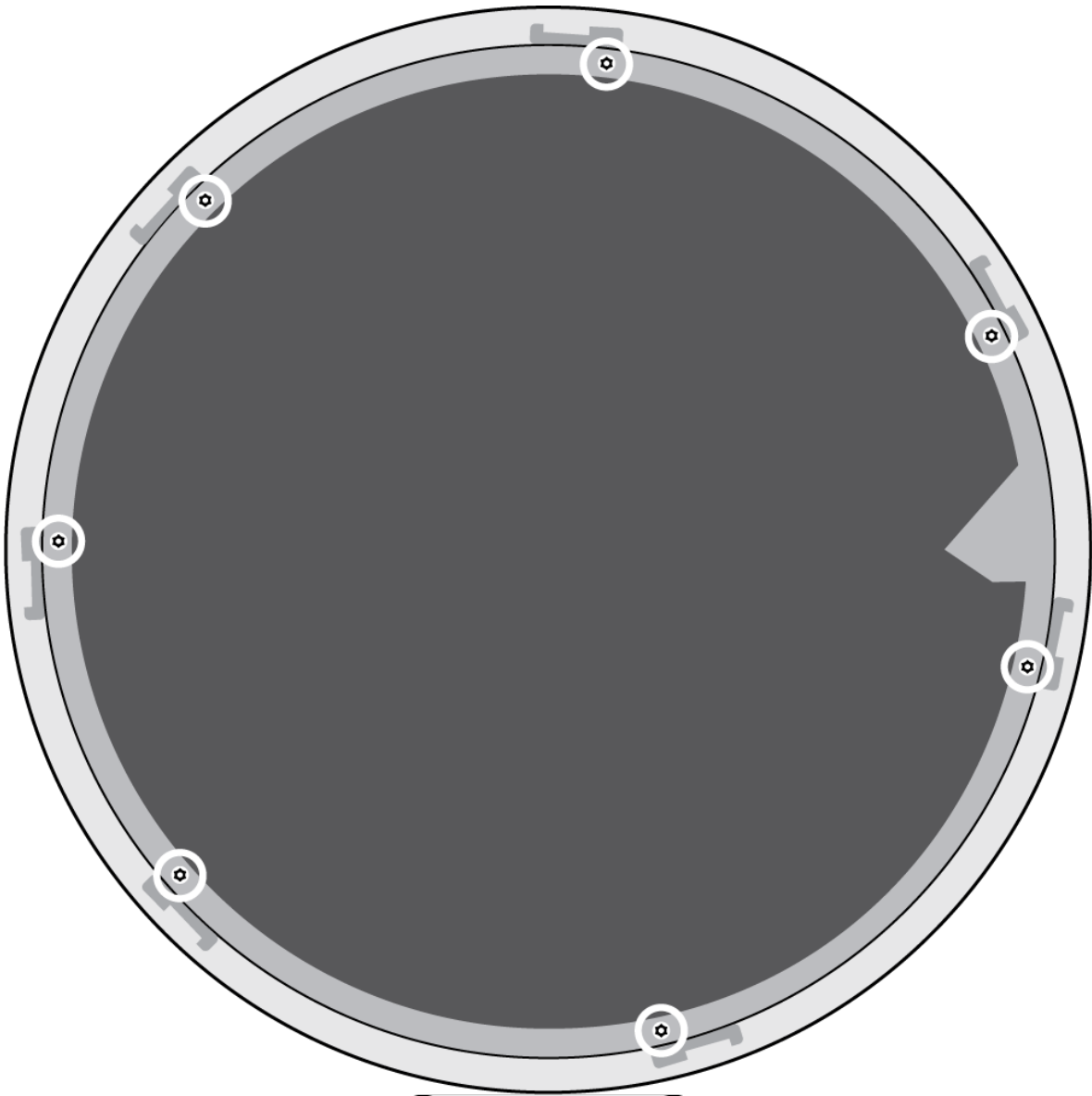

2. Remove the 12 screws that attach the back cover to the processor enclosure. Set the processor enclosure aside with the black board facing up.

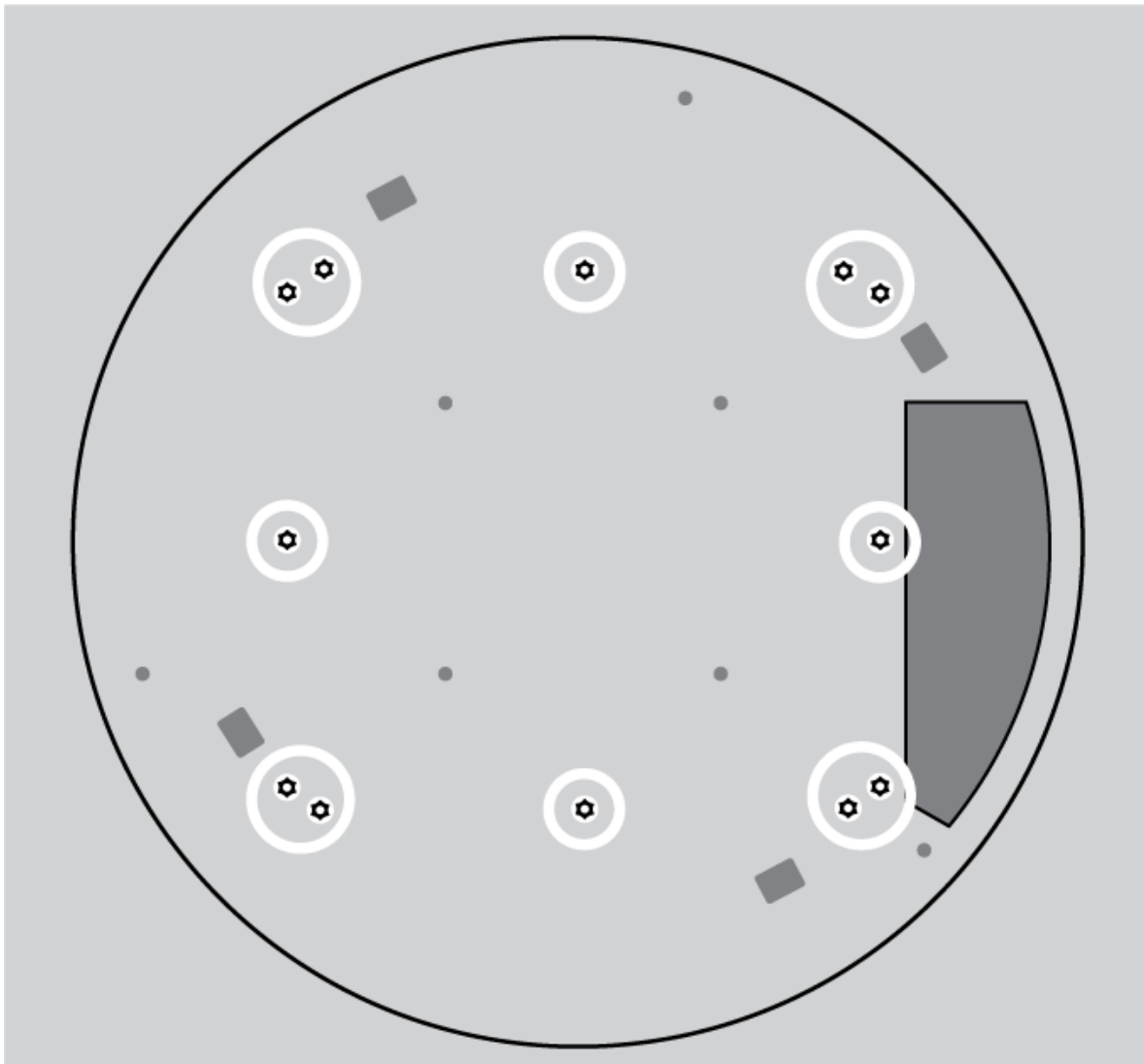

3. Mask the entire flat area in the center of the back cover. Mask the 7 tabs on the inside of the back cover to keep paint out of the screw threads.
4. Paint the outside of the back cover.

Step 3: Reassemble the Microphone

Let the paint dry before reassembling.

1. Use the 12 screws to attach the back cover to the processor.
2. Use the 7 screws to reattach the aluminum support panel.
3. Reinstall the lightpipe on the grille by snapping it into place.
4. Attach the fabric piece to the grille.
5. Align the grille with the 7 tabs on the back cover. Set it down and rotate the grille as shown to engage the tabs.

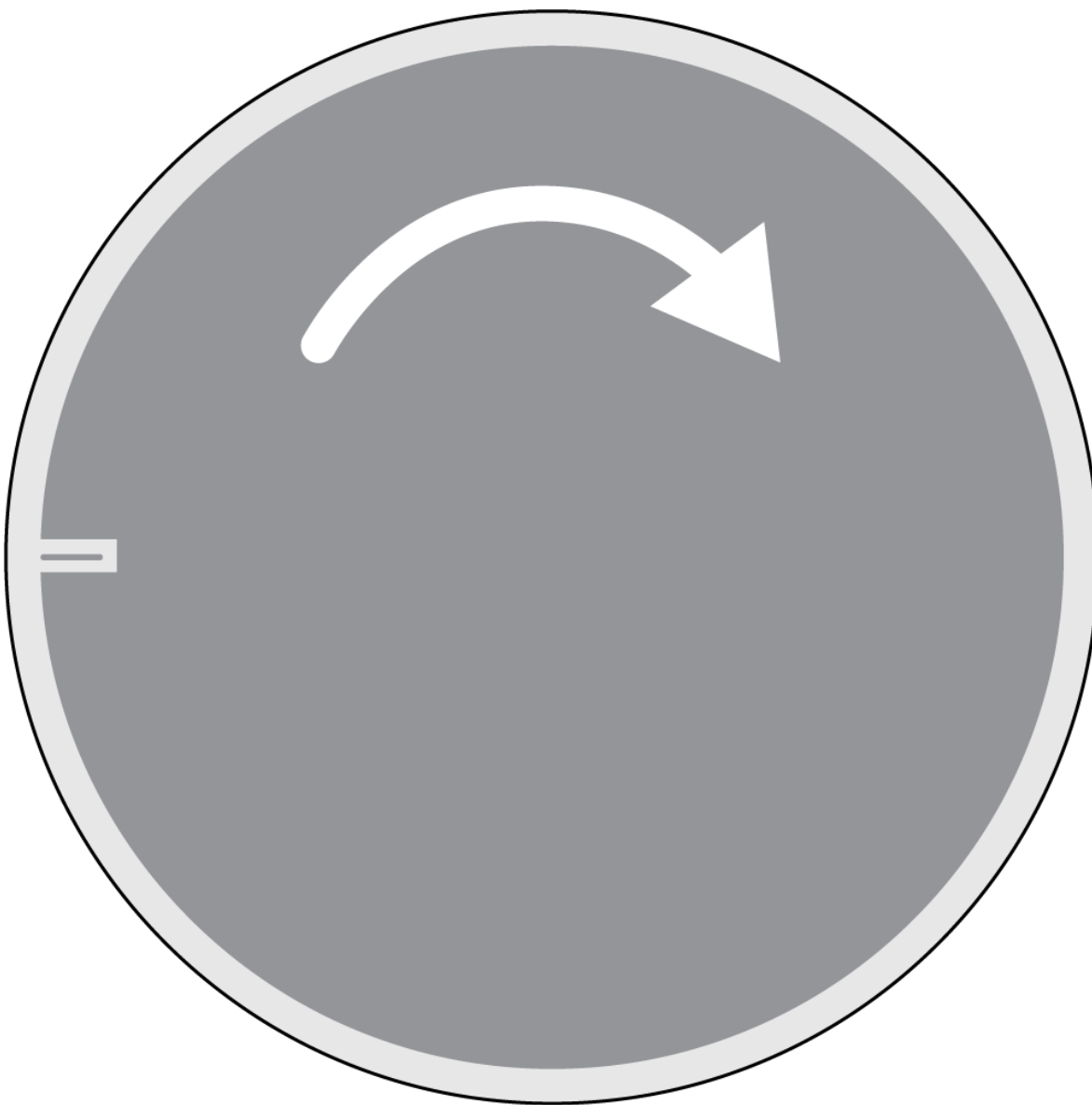

6. Tighten the set screw.

Monitor and Control with External Systems

This device can be monitored and controlled with external systems using the device's REST API or command strings.

Use the REST API

This device has a REST API for easy integration with other enterprise monitoring and control solutions. Use the API to control this device with third-party monitoring and control systems.

Common applications:

- Mute
- LED color and behavior
- Receive coverage information

Shure continues to add API capabilities. Find our complete API documentation at shure.stoplight.io.

The device's API is on by default. To restrict access to the API, go to Settings > Services in Designer or the device's web application.

Use Command Strings

This device receives logic commands over the network. Many parameters controlled through Designer can be controlled using a third-party control system, using the appropriate command string.

Common applications:

- Mute
- LED color and behavior
- Loading presets
- Adjusting levels

See the full list of [MXA925 command strings](#).

Integrate with Camera Control Systems

This microphone provides data about talker position, lobe position, and other settings. You can use this data to integrate the microphone with camera control systems.

There are 2 ways to access the data:

- **Option 1:** [Use the REST API](#)
- **Option 2:** [Use command strings](#)

Send Talker Position Data from Multiple Microphones

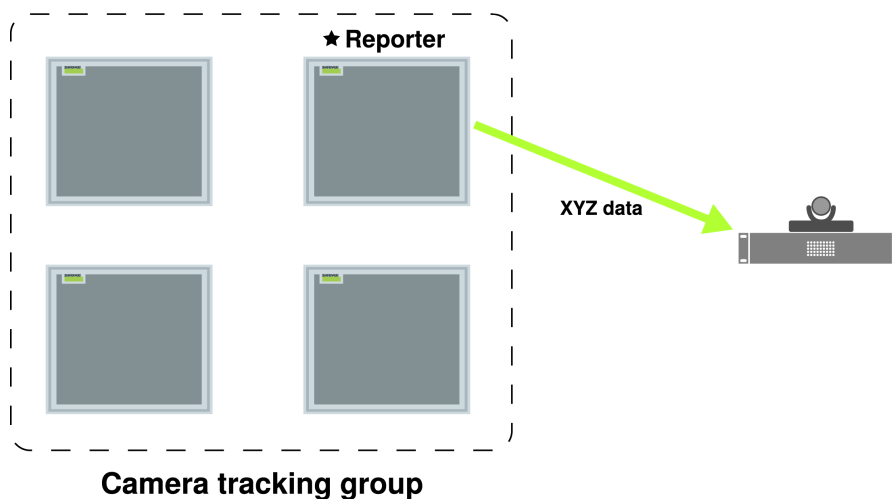

Use the Optimize tracking feature in Designer to send aggregated talker position data. Use the feature to have 1 reporter microphone send talker position data from up to 3 additional follower microphones to camera systems. Camera tracking groups can have up to 4 microphones in each group.

Optimize tracking supports faster deployments since you only need to send command string data from the reporter microphone to the camera system, not all 4 mics individually. The feature also improves X/Y/Z accuracy because the mics can share position data to better find a talker's position.

Before you begin:

- Don't install mics more than 12 ft. (3.6 m) from each other.

- Install all mics in your room and arrange them so that the status LED is in the same position on each mic.
- Arrange mics in the Designer room to match how they're installed. If the mics are installed 8.5 ft. apart, they must be spaced 8.5 ft. apart in the Designer room.
- Enter the device height for each mic in Coverage > Properties > Position.
- Optimize tracking only works in online rooms.
- Optimize tracking is not compatible with Dante device lock.

To set up optimize tracking:

1. Add the mics that you want to group together to the same room in Designer. Up to 4 mics can be in 1 group.
2. Open the online room from Designer's Online rooms list. Go to the room's Coverage view.
3. Click Optimize tracking. The software guides you through setting up a camera tracking group with up to 4 microphones.

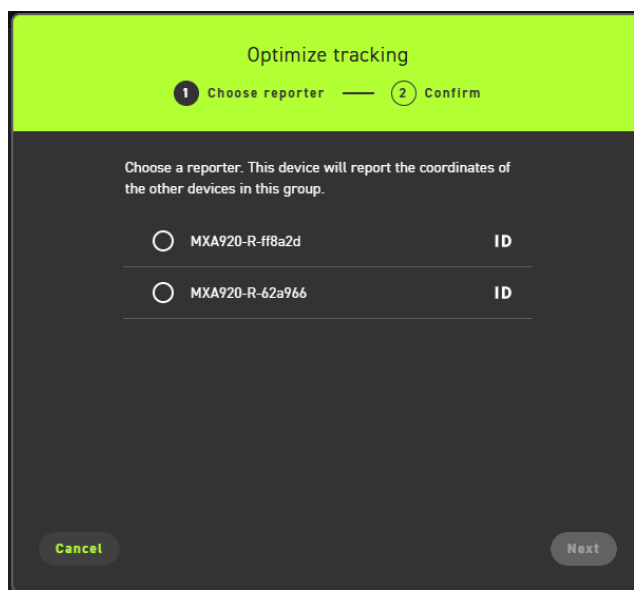

4. After the group is set up, send the appropriate [command string data](#) from the reporter microphone to your camera system. The reporter mic sends talker position data from all mics in the camera tracking group.
5. If you delete a mic in a camera tracking group from an online room, you must run Optimize tracking tracking again. This step ensures that the mics provide accurate talker position information.

Troubleshooting

MXA925 Common Issues

Problem	Solution
No audio or signal is quiet/distorted	<p>Check cables.</p> <p>Verify that output channel isn't muted.</p> <p>Check that output levels are not set too low.</p> <p>Check where audio metering stops. Then check that all Dante and matrix mixer routes have been created correctly.</p> <p>If using automixing, check the settings to ensure channels are gating on and off properly.</p>

Problem	Solution
MXA925 does not power on	Check that MXA925 is plugged in to a PoE source. Test any network cables and connections.
MXA925 doesn't show up in Designer/Shure Update Utility	Ensure that MXA925 has power. Check that Designer and Shure Update Utility are updated to the latest version. Update device firmware to the latest version using Shure Update Utility or ShureCloud. Make sure MXA925 is on the same network as the computer with Designer/Shure Update Utility. Turn off network interfaces not used to connect to the device (such as Wi-Fi). Check that DHCP server is functioning (if applicable). Reset the device if necessary. Refer to no online devices FAQ for more help. Contact Shure if these steps do not resolve your issue.
Flashing red error LED	In the web application, go to Settings > General > Export log to export the device event log. Use the event log to get more information, and contact Shure if necessary.
No lights	Go to [Your device] > Settings > Lights. Check if brightness is disabled or if any other settings are turned off. If the microphone is in a room using Designer's call status feature , mute status LEDs are off when not in a call.

Additional Resources

- [Shure Knowledge Base FAQs](#)
- [Command strings for Shure devices](#)
- [IP Ports and Protocols for Shure Devices](#)
- [Firewall Rules for Shure Software Applications](#)
- [Shure API documentation](#)
- [Shure Enterprise Networking Troubleshooting Checklist](#)
- [Training from Shure Academy](#)
- [Shure Collaboration & Conferencing YouTube channel](#)

Download Shure Software

- [Shure Designer](#)
- [ShureCloud](#)
- [Shure Update Utility](#)
- [Shure Discovery](#)
- [Software and firmware archive](#)

MXA925 Specifications

General

Coverage Type

Automatic or steerable

Power Requirements

Power over Ethernet (PoE), Class 0

Power Consumption

12.5 W maximum

Control Software

Designer or web application

Cable Requirements

Cat5e or higher (shielded cable recommended)

Connector Type

Two RJ45 connectors

Plenum Rating

MXA925-S	UL2043 (Suitable for Air Handling Spaces)
MXA925-R	Not rated

Dust Protection

IEC 60529 IP5X Dust Protected

Operating Temperature Range

-6.7°C (20°F) to 40°C (104°F)

Storage Temperature Range

-29°C (-20°F) to 74°C (165°F)

Audio

Microphone Elements

113 MEMS

Frequency Response

125 Hz to 20 kHz

AES67 or Dante Digital Inputs and Outputs

Channel Count	Automatic coverage on	2 total channels (1 output, 1 AEC reference in channel)
	Automatic coverage off	10 total channels (8 independent transmit channels, 1 automix output, 1 AEC reference in channel)
Sampling Rate		48 kHz
Bit Depth		24

Sensitivity

at 1 kHz

-1.74 dBFS/Pa

Maximum SPL

Relative to 0 dBFS overload

95.74 dB SPL

Signal-to-Noise Ratio

Ref. 94 dB SPL at 1 kHz

75.76 dB A-weighted

Latency

Does not include Dante latency

Direct outputs (Automatic coverage off)	13 ms
Automix output (AI AEC on)	47 ms
Automix output (AI deverb on, AI AEC on or off)	90 ms
Automix output (AI denoiser on, AI AEC and AI deverb on or off)	93 ms

Self Noise

18.24 dB SPL-A

Dynamic Range

77.5 dB

Digital Signal Processing

Automatic mixing, AI acoustic echo cancellation, noise reduction, AI denoiser, automatic gain control, compressor, delay, AI deverb, equalizer (4-band parametric), mute, gain (140 dB range)

MXA925 Frequency Response

Frequency response measured directly on-axis from a distance of 6 feet (1.83 m).

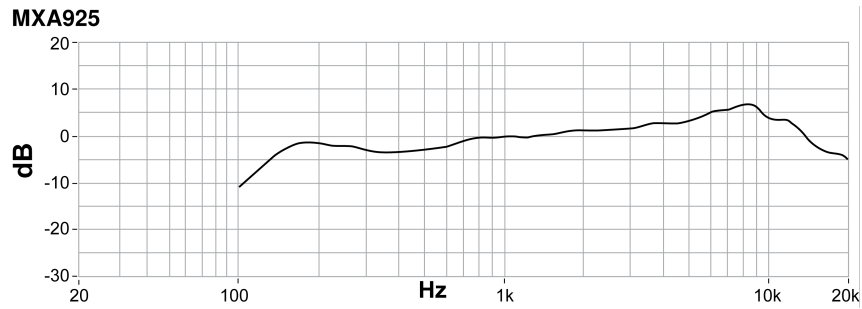

Dimensions

Weight

- MXA925-S: 11.8 lb. (5.4 kg)
- MXA925-R: 12.7 lb. (5.8 kg)

MXA925-S



- A (Microphone flange): 0.41 in. (10.5 mm)
- B (Edge to edge): 23.77 in. (603.8 mm)
- C (Height): 2.15 in. (54.69 mm)

MXA925-S-60CM

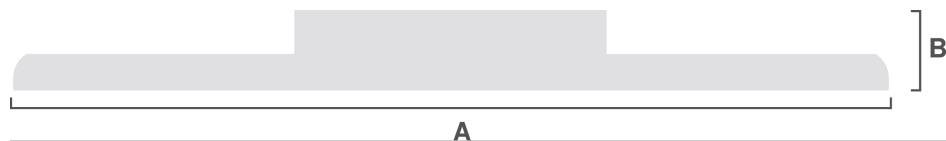

- A (Edge to edge): 23.38 in. (593.8 mm)
- B (Height): 2.15 in. (54.69 mm)

MXA925-R



- A (Height to top of eyelets): 2.4 in. (61.3 mm)
- B (Outer diameter): 25 in. (635.4 mm)

Important Safety Instructions

1. READ these instructions.
2. KEEP these instructions.
3. HEED all warnings.
4. FOLLOW all instructions.
5. DO NOT use this apparatus near water.
6. CLEAN ONLY with dry cloth.
7. DO NOT block any ventilation openings. Allow sufficient distances for adequate ventilation and install in accordance with the manufacturer's instructions.
8. DO NOT install near any heat sources such as open flames, radiators, heat registers, stoves, or other apparatus (including amplifiers) that produce heat. Do not place any open flame sources on the product.
9. DO NOT defeat the safety purpose of the polarized or grounding type plug. A polarized plug has two blades with one wider than the other. A grounding type plug has two blades and a third grounding prong. The wider blade or the third prong are provided for your safety. If the provided plug does not fit into your outlet, consult an electrician for replacement of the obsolete outlet.
10. PROTECT the power cord from being walked on or pinched, particularly at plugs, convenience receptacles, and the point where they exit from the apparatus.
11. ONLY USE attachments/accessories specified by the manufacturer.
12. USE only with a cart, stand, tripod, bracket, or table specified by the manufacturer, or sold with the apparatus. When a cart is used, use caution when moving the cart/apparatus combination to avoid injury from tip-over.



13. UNPLUG this apparatus during lightning storms or when unused for long periods of time.
14. REFER all servicing to qualified service personnel. Servicing is required when the apparatus has been damaged in any way, such as power supply cord or plug is damaged, liquid has been spilled or objects have fallen into the apparatus, the apparatus has been exposed to rain or moisture, does not operate normally, or has been dropped.
15. DO NOT expose the apparatus to dripping and splashing. DO NOT put objects filled with liquids, such as vases, on the apparatus.
16. The MAINS plug or an appliance coupler shall remain readily operable.
17. The airborne noise of the Apparatus does not exceed 70dB (A).
18. Apparatus with CLASS I construction shall be connected to a MAINS socket outlet with a protective earthing connection.
19. To reduce the risk of fire or electric shock, do not expose this apparatus to rain or moisture.

20. Do not attempt to modify this product. Doing so could result in personal injury and/or product failure.
21. Operate this product within its specified operating temperature range.
22. Follow local regulations and consult qualified personnel if the product installation or relocation requires construction work. Choose mounting hardware and an installation location that can support the weight of the product. Avoid locations subject to constant vibration. Use the required tools to install the product properly. Inspect the product periodically.
23. If your product has a feature to log in, upon first time start up, you must change your password.

WARNING:

- Voltages in this equipment are hazardous to life. No user-serviceable parts inside. Refer all servicing to qualified service personnel. The safety certifications do not apply when the operating voltage is changed from the factory setting.
- If water or other foreign objects enter the inside of the device, fire or electric shock may result.

Additional Safety Warnings on Mounting

- **Only for use of specified products.** Do not use the mount for any other equipment. Using the mount for other equipment could cause the mount to fail and the equipment to fall. Please read all safety warnings and general mounting instructions of the specified products.
- **Follow product mounting instructions.** Failure to properly assemble and install the mount according to the instructions can lead to serious personal injury or damage to equipment.
- **Mount to a secure structure.** The mount must be secured to a structural component, to ensure it can support the intended weight. Avoid surfaces or areas with strong vibrations. When mounting to a surface other than a wall, use the right mounting hardware for such surface and ensure the mounting surface is strong enough to support the weight. Do not mount on unsupported surfaces like unreinforced drywall. Ensure the surface can support the weight of the object, which may require professional consultation.
- **Avoid over-tightening screws.** Over-tightening can cause damage to the bracket or the mounting surface, which may reduce the mount's holding power.
- **Use the correct hardware.** Only use the screws, fasteners and other hardware provided. Using the wrong hardware could cause the bracket to loosen or fail.
- **Keep children away.** The product may contain small hardware that poses a choking hazard. Always keep children away from the work area.
- **Indoor use only.** The mount is intended for indoor use only. Outdoor environments with exposure to environmental conditions and temperature changes can cause components to degrade.
- **Regular checks:** Check that the product is secure and safe to use at regular intervals (e.g., every three months).

Important Product Regulatory Information

EMC conformance testing is based on the use of supplied and recommended cable types. The use of other cable types may degrade EMC performance.

Cybersecurity STATEMENT OF COMPLIANCE

Product Type: Relevant connectable products defined as internet-connectable products or network-connectable products, in line with inter alia Product Security and Telecommunications Infrastructure Act 2022.

Manufacturer Statement: We, Shure Incorporated, certify and declare as manufacturer under our sole responsibility, that the above-mentioned product(s) conform(s) to the legislation as mentioned under Attachment 1 – to Cybersecurity Statement of Compliance listed here: <https://www.shure.com/en-GB/about-us/security>.

Information on how to report security issues: The latest version of Shure's Disclosure policy can be found at the following link: <https://www.shure.com/en-GB/about-us/security>

Security update periods: Shure provides support regarding hardware and software updates that continue the integral cyber security safety of Shure products up to 24 months after end of life (AEOL). For the full statement regarding Shure's product

support policy, and information regarding products end of life status information can be found at the following link: <https://www.shure.com/en-GB/about-us/security>

Manufacturer:

Shure Incorporated 5800 Touhy Avenue
Niles, Illinois, 60714-4608 U.S.A. Website: www.Shure.com.

Technical documentation is kept at:

Shure Incorporated, Corporate Global Compliance Engineering Division

UK Importer/Representative:

Shure UK Limited
Unit 2, The IO Centre, Lea Road, Waltham Abbey, Essex, EN9 1AS, U.K.
Phone: +44 (0)1992 - 703058
Email: EMEAsupport@shure.de

On behalf of Manufacturer:

Chad Ayers
08 May 2025 Niles, Illinois
Senior Director, Global Compliance

CE Notice

Hereby, Shure Incorporated declares that this product with CE Marking has been determined to be in compliance with European Union requirements.

The full text of the EU declaration of conformity is available at the following site: <https://www.shure.com/en-EU/support/declarations-of-conformity>.

UKCA Notice

Hereby, Shure Incorporated declares that this product with UKCA Marking has been determined to be in compliance with UKCA requirements.

The full text of the UK declaration of conformity is available at the following site: <https://www.shure.com/en-GB/support/declarations-of-conformity>.

FCC Notice

This equipment has been tested and found to comply with the limits for a Class B digital device pursuant to Part 15 of the FCC Rules. These limits are designed to provide reasonable protection against harmful interference when the equipment is operated in a residential installation. This equipment generates, uses, and can radiate radio frequency energy and, if not installed and used in accordance with the instructions, may cause harmful interference with radio communications. However, there is no guarantee that interference will not occur in a particular installation. If this equipment does cause harmful interference with ra-

dio or television reception, which can be determined by turning the equipment off and on, you are encouraged to try to correct the interference by one or more of the following measures:

- Reorient or relocate the antenna of the radio/television receiver.
- Increase the separation between this equipment and the radio/television receiver.
- Plug the equipment into a different outlet so that the equipment and the radio/television receiver are on different power mains branch circuits.
- Consult a representative of Shure or an experienced radio/television technician for additional suggestions.

This device complies with Part 15 of the FCC Rules. Operation is subject to the following two conditions:

1. This device may not cause harmful interference.
2. This device must accept any interference received, including interference that may cause undesired operation.

Notice: The FCC regulations provide that changes or modifications not expressly approved by Shure Incorporated could void your authority to operate this equipment.

For information regarding responsible party and other matters relating to FCC compliance, please contact Shure Incorporated, 5800 W. Touhy Avenue, Niles, Illinois 60714-4608 U.S.A. shure.com/contact

Canada, ISED Notice

Notice: The Industry Canada regulations provide that changes or modifications not expressly approved by Shure Inc. could void your authority to operate this equipment.

This Class B digital apparatus complies with Canadian ICES-003. Cet appareil numérique de la classe B est conforme à la norme NMB-003 du Canada.

Waste Electrical and Electronic Equipment (WEEE) Directive



In the European Union and the United Kingdom, this label indicates that this product should not be disposed of with household waste. It should be deposited at an appropriate facility to enable recovery and recycling.

Registration, Evaluation, Authorization of Chemicals (REACH) Directive

REACH (Registration, Evaluation, Authorization of Chemicals) is the European Union (EU) and the United Kingdom (UK) chemical substances regulatory framework. Information on substances of very high concern contained in Shure products in a concentration above 0.1% weight over weight (w/w) is available upon request.

Recycling Information

Please consider the environment, electric products and packaging are part of regional recycling schemes and do not belong to regular household waste.

Suitable for use in air plenums per NEC section 300.22(c) and/or IMC section 602.

Meets the UL 2043 standard for use in plenum spaces.

部件名称	有害物质									
	Pb	Cd	Hg	Cr(VI)	PBB	PBDE	DBP	BBP	DIBP	DEHP
电路模块	X	○	○	○	○	○	○	○	○	○
金属模块	X	○	○	○	○	○	○	○	○	○
线缆及其组件	X	○	○	○	○	○	○	○	○	○
电源适配器*	X	○	○	○	○	○	○	○	○	○
锂电池组*	X	○	○	○	○	○	○	○	○	○

注 1: ○: 表示该有害物质在该部件所有均质材料中的含量均不超出电器电子产品有害物质限制使用国家标准要求。
X: 表示该有害物质至少在该部件某一均质材料中的含量超出电器电子产品有害物质限制使用国家标准要求。

注 2: 本产品大部分的部件采用无害的环保材料制造, 含有有害物质的部件皆因全球技术发展水平的限制而无法实现有害物质的替代。

注 3: 以上未列出的部分, 表明其有害物质含量均不超出电器电子产品有害物质限制使用国家标准要求

*: 表示如果包含部分